

# Electronics Reference Data

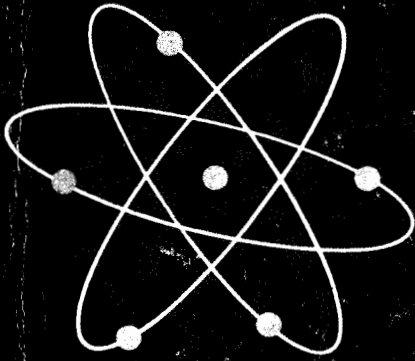

## TV CIRCUITS AND APPLICATIONS

- Television Inter-Carrier Sound Reception
- Video I.F. Design
- Cathode-Ray High-Voltage Supplies
- Television Interference Filters
- Television Reception at "Shadowed" Locations

## CIRCUITS

- Electronic Oscillators
- Regulated Power Supply Design
- Ferroresonant Circuits

## WAVE FORMS AND WAVE SHAPING

- Non-Sinusoidal Wave Forms
- Audio Frequency Distortion Measurements

## COMPONENTS

- Fixed Capacitors in Modern Circuitry
- Proper Use of By-pass Condensers
- Non-Linear Resistors
- Amateur Applications of Crystal Diodes
- Proper Electronic Wiring Techniques

## METERS AND MEASUREMENTS

- The Direct-Current Meter
- High Resistance Non-Electronic D.C. Voltmeters
- Applications of the Electrometer
- Improved, Crystal-Type Noise Generator

## SPECIALIZED APPLICATION AND DEVELOPMENT

- Using Standard Time and Frequency Broadcasts
- Photoelectric Cell Applications
- Printed Electronic Circuits
- The Transistor, An Amplifying Crystal
- Junction Transistor Circuits
- Class-B Transistor Amplifier Data
- Load Lines in Transistor Amplifier Design
- Simple, Inexpensive Geiger Counters
- Recent Trends in Single-Sideband Communication
- The Citizens Radio Service
- Elementary Binary Arithmetic

~~42.00~~

FJ

# Electronics Reference Data

ERA-1

FIRST EDITION  
FIRST PRINTING—JULY, 1957



Reproduction or use, without express permission, of editorial or pictorial content, in any manner, is prohibited. No patent liability is assumed with respect to the use of the information contained herein.

© Howard W. Sams & Co., Inc., 1957  
Indianapolis 5, Indiana

PRINTED IN U. S. A.

*Published by*

HOWARD W. SAMS & CO., INC.  
INDIANAPOLIS 5, INDIANA

A *Howard W. Sams*

PHOTOFACT PUBLICATION

## TABLE OF CONTENTS

Section	Page
<b>I TV Circuits and Applications</b> ..... Television Inter-carrier Sound Reception—Video I.F. Design— Cathode-ray High-voltage Supplies—Television Interference Fil- ters—Television Reception at “Shadowed” Locations	<b>1</b>
<b>II Circuits</b> ..... Electronic Oscillators—Local Oscillators in AM Receivers—Track- ing—VHF and UHF Oscillator Circuits—Regulated Power Supply Design—Ferroresonant Circuits	<b>15</b>
<b>III Components</b> ..... Fixed Capacitors in Modern Circuitry—Proper Use of By-pass Condensers—Non-Linear Resistors—Amateur Applications of Cryst- tal Diodes—Proper Electronic Wiring Techniques	<b>39</b>
<b>IV Wave Forms and Wave Shaping</b> ..... Non-sinusoidal Wave Forms—Passive Wave Shaping Circuits— Generators and Non-linear Shapers—Audio Frequency Distortion Measurements—Methods of Measurement—A Practical Distortion Analyzer	<b>55</b>
<b>V Meters and Measurements</b> ..... The Direct-current Meter—High-resistance Non-electronic D.C. Voltmeters—Applications of the Electrometer—Improved, Crystal- type Noise Generator	<b>67</b>
<b>VI Specialized Application and Development</b> ..... Using Standard Time and Frequency Broadcasts—Photoelectric Cell Applications—Printed Electronic Circuits—The Transistor, an Amplifying Crystal—Junction Transistor Circuits—Class-B Tran- sistor Amplifier Data—Load Lines in Transistor Amplifier Design— Simple, Inexpensive Geiger Counters—Recent Trends in Single- Sideband Communication—The Citizens Radio Service—Elementary Binary Arithmetic	<b>85</b>
<b>INDEX</b> .....	<b>119</b>

# SECTION I

## TV CIRCUITS AND APPLICATIONS

### Television Inter-Carrier Sound Reception

IN all present-day television systems, the sound, picture and synchronization information are transmitted simultaneously over a six-megacycle-wide television channel. Prior to 1942, this was accomplished solely by the use of an amplitude-modulation (AM) method, in which the audio intelligence and the video intelligence were each impressed on two completely separate carriers which differed in frequency by 4.5 megacycles. Subsequent developments in the art demonstrated the desirability of utilizing the much-enhanced fidelity and noise reduction properties inherent in frequency-modulation (FM) to improve the audio performance of the television system, and as a direct consequence to increase listener enjoyment and acceptance of the then new mode of entertainment. This combination of AM for the video carrier and FM for the sound carrier, with transmission standards as established by the F. C. C., is currently in use by all television broadcasting stations in this country. This change-over from AM sound to FM sound, while requiring rather extensive modification of the transmitter, did not involve obsolescence of existing TV receivers, since the FM sound could be received by the slope detection method. Fig. 1 graphically illustrates a typical spectrum analysis for one of the 12 U. S. channels in use at the present time.

In recent years, a number of schemes have been disclosed for the simultaneous transmission of both picture and

sound on a single carrier. In general these systems were based on the use of a multiplex or time-division method of transmission in which it was proposed that the audio modulation be impressed on the video carrier during the intervals normally reserved for the synchronization pulses. Because of the fact that these sync pulses oc-

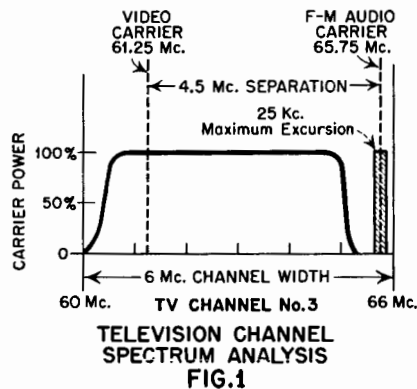

cur only during the blanked portion of the kinescope trace, audio signals transmitted during the retrace or fly back period should cause no interference with the picture. However, since the ratio of sync pulse duration to video pulse duration is quite small, roughly 10%, the average audio power which can be transmitted during the sync pulse interval, with a given carrier, is correspondingly reduced by a factor of 10. This could be overcome to some degree by increasing either the sensitivity of the receiver or the transmitter power. Another serious objection exists in the fact

that adoption of such a system would not only require a major modification of the transmitters but would also make existing receivers obsolete.

In 1947, exposition was made in papers by L. W. Parker, and R. B. Dome, of the development of a new method for recovery of the audio intelligence contained in a composite television signal. In this system, a 4.5 Mc. beat frequency, usually present as an undesired signal in the control grid circuit of the kinescope, is made to serve as what may be termed an audio sub-i.f. signal which can be amplified, clipped or limited and then demodulated in the usual manner. That such a 4.5 Mc. signal can exist may readily be seen from the following generalized consideration. It may be mentioned in passing that even though this ordinarily undesired signal is usually present in greater or lesser degree in all TV receivers, only one manufacturer, to the writers knowledge, has made particular provision for 4.5 Mc. trapping in the video amplifier circuit.

It will be remembered that in a conventional superheterodyne receiver, an incoming signal of frequency  $F$  and a locally generated oscillator signal of frequency  $f$ , are both passed through some non-linear device, variously termed the mixer, converter or first detector. In the conversion process the two signals are combined and form an i.f. signal of frequency equal to the difference between  $F$  and  $f$ . It must be stressed at this point however that this heterodyne or beat frequency will be generated only if the mixing

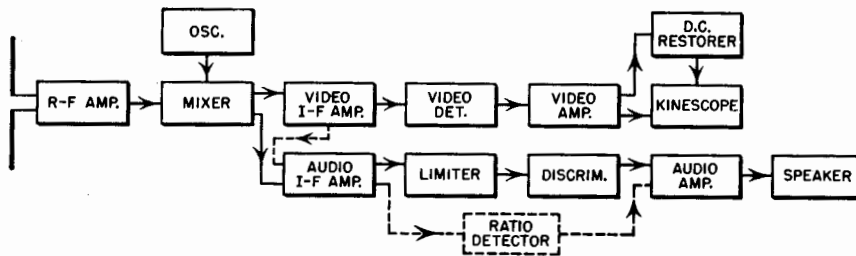

CONVENTIONAL DUAL-I-F TV RECEIVER  
FIG. 2

device (vacuum tube, crystal diode, thermistor, etc.) possesses some non-linearity in its impedance characteristic.

In the conventional dual-i. f. television receiver, both the picture and sound carriers, comprising the composite television signal, are amplified by a common broad-band r. f. stage, heterodyned with a single local oscillator signal and converted to a complex signal containing video and audio i.f. components. Although the conversion process lowers the frequency of the two carriers, the 4.5 Mc. frequency difference between them remains unaltered. If, as is usually the case, the oscillator is operated on the high frequency side of the signal, a sideband reversal takes place, i. e., the relative positions of the video and audio carriers are interchanged.

The use of a common r. f. amplifier, mixer and oscillator for both picture and sound adds to ease of operation and at the same time affords a material saving in cost. A natural extension of this dual function technique to the i. f. portion of the receiver has resulted in the recent appearance on the market of several commercially designed TV receivers in which one, or even two of the i.f. stages are made to function as combined picture and sound amplifiers. From this point on, two signals are separated by appropriate filters or traps, amplified further as required and then demodulated, as shown in Fig. 2.

In the intercarrier sound system, Fig. 3, both the picture and sound i. f.

signals are handled simultaneously by a common wide band multistage i. f. amplifier. In the video detector, usually a vacuum tube or germanium crystal diode, the frequency modulated sound i. f. signal is heterodyned with the amplitude modulated video i. f. signal. The resulting 4.5 Mc. beat, produced by the non-linearity of the detector characteristic, is both frequency modulated by the sound and amplitude modulated by the video. It has been shown, however, that if a low level FM signal is heterodyned with a high level AM signal, the resultant signal is largely frequency modulated and is relatively free of AM. This 4.5 Mc. sub-i. f. is further amplified by the video amplifier, passed through one or more amplifier limiter stages where the residual AM is removed, and is finally demodulated by any of the well-known methods of FM detection. Use of the ratio detector for this function provides adequate AM clipping without resort to a separate limiter.

Although not adequately demonstrated by the simple block-diagrams of Figs. 2 and 3, the intercarrier system represents a considerable simplification in circuitry when compared with the actual schematic of the dual-i. f. system of television reception. In addition to this advantage, with its attendant economy, the Parker system possesses several other desirable characteristics among which may be mentioned simplicity of tuning, freedom from oscillator drift and microphonism, and reduction of inter-channel crosstalk.

The dual-i.f. television receiver suffers from the serious disadvantage that even comparatively slight mistuning or drift of the local oscillator seriously affects both audio quality and discriminator impulse-noise susceptibility. In common with other types of FM receptor, background noise and hiss are also increased by such oscillator maladjustment. Automatic frequency control of the oscillator has been applied in certain television models as a means of reducing these shortcomings, but this of course adds to the complexity and consequently to the cost. A commentary on the efficacy of AFC circuits as applied to TV receivers may be made by noting that one manufacturer, after marketing a receiver using AFC, subsequently issued a modification kit for adding a fine tuning control to sets in the field.

These conditions are further aggravated by the fact that the TV sound deviation is only 12.5 kc. as compared with 37.5 kc. for standard FM broadcast transmissions. The discriminator coil Q can therefore usually be made higher, requiring almost pinpoint accuracy in TV set tuning.

Sixty-cycle frequency modulation of the local oscillator in the standard dual-i.f. system, due to insufficient filtering or cathode-heater leakage, is often manifested as objectional hum in the speaker. In one commercially built set, it was found necessary to include a small dry-disc rectifier and filter to supply pure d. c. to the heater of the local oscillator to reduce such hum. Acoustic feedback from the speaker diaphragm to any microphonic portion of the oscillator circuit, such as trimmer condenser plates, switch contacts, coil slugs, tube elements, and the like, can cause annoying ringing or even audio howl at high volume.

The Parker System, in which constancy of the 4.5 Mc. frequency difference between carriers, which is used as the sound i.f., is maintained by accurate control at the transmitter rather than by the relationship existing between re-

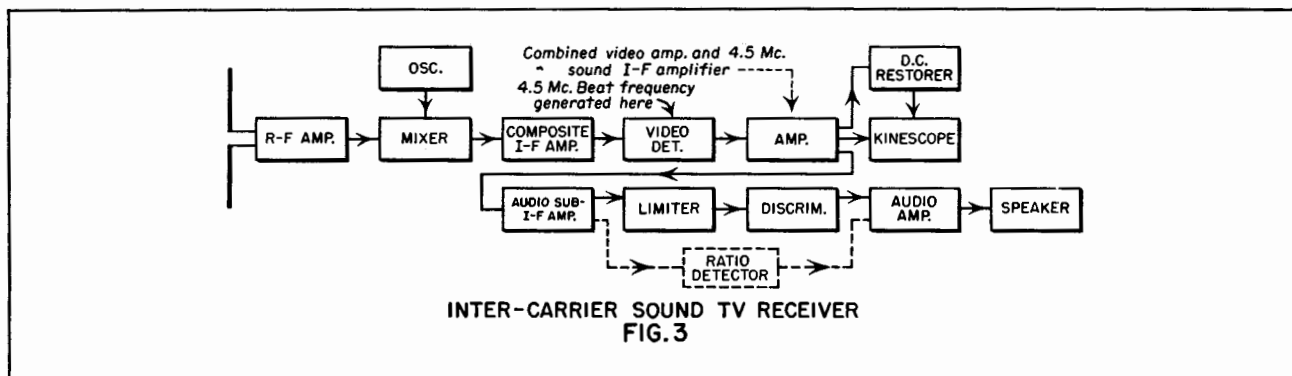

INTER-CARRIER SOUND TV RECEIVER  
FIG. 3

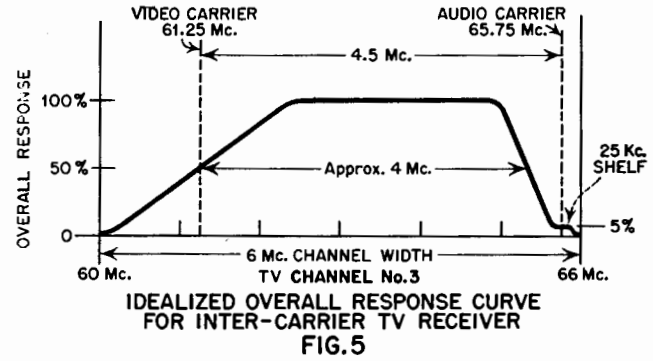
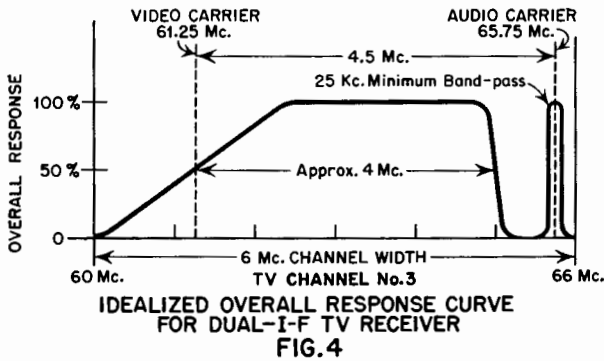

ceived and locally generated signals, is immune to these troubles. Since the video i.f. is normally of the wide band type, misadjustment or drift of the local oscillator sufficient to cause severe distortion of the sound in dual-i.f. receivers, causes no appreciable degradation of either picture or sound quality in sets equipped for intercarrier sound reception.

The discussion thus far of the comparison between the two systems has been confined to the credit side of the inter-carrier ledger. There are, of course, the ever present debits. Chief among these is the susceptibility of the inter-carrier system to audio interference caused by; (a) frequency or phase modulation of the video carrier, (b) momentary disappearance of the video carrier during modulation peaks, (c) failure at the transmitter to accurately maintain the prescribed 4.5 Mc. difference between video and audio carriers, and (d) drift of the receiver discriminator tuned circuits.

The remedial measures necessary to reduce the above effects present no insurmountable problems, as may be seen from the following considerations:

(a) Frequency or phase modulation of the video carrier appears, in the Parker system, as undesired modulation and distortion products in the reproduced sound. This can be prevented, or at least minimized, by proper transmitter design and adjustment.

(b) Since the inter-carrier system depends upon both carriers for its sound reproduction, it is evident that momentary disappearance of the video carrier, such as might be caused by over-modulation of the transmitter, also causes interruption of the sound. By imposing the limitation at the transmitter that the picture carrier shall never fall below 10 or 15% of maximum amplitude, the possibility of such sound "break-up" is prevented. Another effect which has symptoms very similar to sound break-up by video carrier disappearance is that occasioned when one of the video i. f. amplifier stages is driv-

en to cutoff, as it is sometimes possible to do by improper adjustment of the contrast control. Since the peak signals are the "sync" pulses, which are in the infra-black region, this type of operation is not necessarily deleterious to the performance of the dual-i. f. sets. In the Parker system, however, operation at cutoff results in sound break-up.

(c) Failure at the transmitter to accurately maintain the 4.5 Mc. spacing between the video and audio carriers results in the same kind of audio performance degradation as that caused by misadjustment of the tuning control or discriminator circuit in the conventional dual-i. f. system. Whereas this condition can easily be corrected by the user of the older system by adjustment of the fine-tuning control, the inter-carrier arrangement must depend upon the broadcaster for the correction of this condition.

(d) The effects of drift in the discriminator circuit of the inter-carrier sound system are usually slight since the sound sub-i. f. is at a relatively low frequency and can be virtually eliminated by careful design and the judicious use of small fixed capacitors having the proper capacitance versus temperature characteristic.

Figs. 4 and 5 show the overall response curves for the two TV systems discussed above. The only difference lies in the shape of the curves in the vicinity of the sound portion of the spectrum. In the dual-i.f. system, full response over at least a 25 kc.

band-width, centered on the sound "resting" frequency is desired, while in the inter-carrier method the sound acceptance notch is in the form of a small shelf of similar width and center frequency. The reason for a plateau rather than a gradual roll-off for the intercarrier sound response is that in this way partial demodulation of the FM sound by slope detection, and possible picture interference is prevented. As shown by Fig. 5, the response at the sound shelf should not exceed 5% of full amplitude. This, as mentioned earlier, reduces the video amplitude modulation of the sound sub-i. f. to a negligible value and also prevents possible distortion of the picture by the sound modulation.

The sound trapping requirements in the Parker system are not nearly so stringent as in conventional sets. A single trap, providing about 26 db. of attenuation is required immediately preceding the video detector to reduce the sound response to the 5% level. This rather large attenuation is subsequently compensated for by the additional gain of the one or two video amplifier stages.

In closing, it may be remarked that the results of rather extensive field tests, and the likelihood of industry-F. C. C. cooperation in setting up the transmission standards necessary for insuring satisfactory performance, may well lead to the eventual complete adoption of the inter-carrier system for television sound reception.

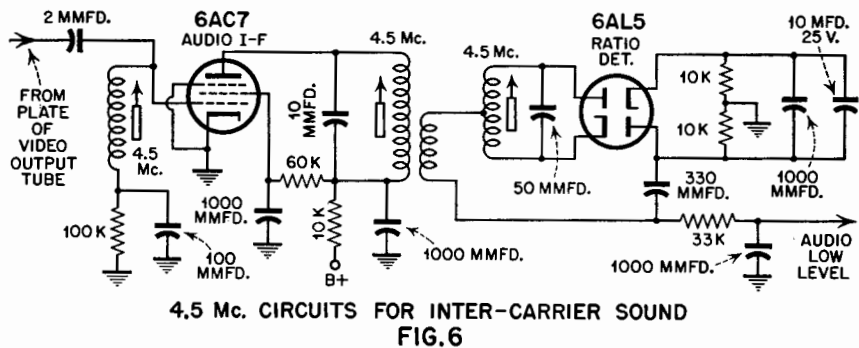

# Video I. F. Amplifier Design

**I**N modern radio communication and pulse ranging equipment, the necessity of transmitting and receiving a large amount of intelligence per unit time, or of handling wave forms which contain high frequency components, imposes difficult requirements upon the bandwidth of the circuits involved. In the radar system, for instance, the modulation of the transmitter by very short, rectangular pulses of energy, results in the r.f. output occupying a broad band or *spectrum* of frequencies. The width in megacycles of the band required for the transmission of such rectangular pulse signals is expressed, to a rough approximation, by:

$$(1) \quad \text{Bandwidth (mc.)} = \frac{2}{\text{Pulse length (Microseconds)}}$$

Thus, a radar transmitter being modulated by .5 microsecond pulses would occupy a band (exclusive of minor side bands) of 2 divided .5 or 4 megacycles. In television, the transmission of high-definition picture information consisting of several million elements per second, as well as synchronizing pulses and sound, requires the allocation of a 6 megacycle channel for each transmitter in operation.

In any such broad bandwidth system, if the receiver is to recover as much of the transmitted signal as possible, it must be capable of simultaneously accepting the entire band of frequencies transmitted and amplifying each equally. In the super-heterodyne type of receiver, the satisfaction of this requirement greatly affects the design of the i. f. amplifier, since it is this channel of the receiver which determines the overall selectivity to a large extent.

Fortunately, the design of broad-band or "video" intermediate-fre-

quency amplifiers has been greatly simplified by war-time research work. As a result, the design of high gain amplifiers capable of essentially "flat" band-pass characteristics as wide as 10 megacycles is relatively uncomplicated.

The bandwidth of an i.f. amplifier is taken as the frequency difference between points 3 db. down from maximum amplitude on each side of the response curve and is symbolized by  $\Delta f$ . See Fig. 1. In the simplest form of amplifier stage, which is the single-tuned circuit shown in Fig. 2, the bandwidth in megacycles is given by:

$$(2) \quad \text{Bandwidth } (\Delta f) = \frac{1}{2\pi RC}$$

R = the total resistance shunting the tuned coil in ohms.  
C = the total capacitance shunting the coil in mmf.

As this relation shows, the bandwidth of a single-tuned stage is inversely proportional to both the shunt capacity and the shunt resistance. In practice it is the resistance which is varied to control the shape of the response curve. The addition of "loading resistors" across the tuned circuits, common in television and other video i.f. circuits, broadens the response as is illustrated by the dotted curve in Fig. 1. Loading the resonant circuit lowers the circuit Q and thus reduces the maximum response or gain as is shown. The bandwidth at the new 3 db. point has been increased but the peak response has been sacrificed proportionately in favor of bandwidth. This demonstrates the important fact that the gain-bandwidth product of such an amplifier is a constant. This means that a stage giving a gain of 10 over a bandwidth of 1 megacycle may also be made to deliver a gain of 5 at a

2 megacycle band-pass, or any other combination whose gain-bandwidth product ( $G \times B$ ) is equal to ten. The gain-bandwidth product, which is the accepted "figure of merit" of an amplifier stage, depends on the transconductance (gm) of the tube type used and the *total* distributed shunt capacity in the following manner:

$$(3) \quad G \times B \text{ (mc.)} = \frac{g_m}{2\pi C}$$

Since the gain-bandwidth product is inversely proportional to C, which includes the distributed wiring capacity as well as the tube interelectrode capacitances appearing across L, it is very important in circuit lay-out to reduce stray capacity to a minimum. In practical circuits using modern tubes, the total C may be limited to 10 mmf. Table I shows the GxB products for some frequently used tubes, allowing 5 mmf. for distributed circuit capacity.

TUBE TYPE	Trans-conductance (Micromhos)	Tube Capacity + 5 mmf.	Gain-Bandwidth Product (Megacycles)
6AC7	9000	21	68.7
6AU6	5200	15.5	53.6
6BA6	4400	15.5	45.3
6AG5	5000	13.3	59.5
6AK5	5000	11.4	69.4

TABLE I

Unfortunately, when single-tuned amplifier stages resonated to the same frequency (synchronously tuned) are cascaded, the overall band-pass does not remain that of the individual stages, but is reduced radically with the number of stages. Four stages,

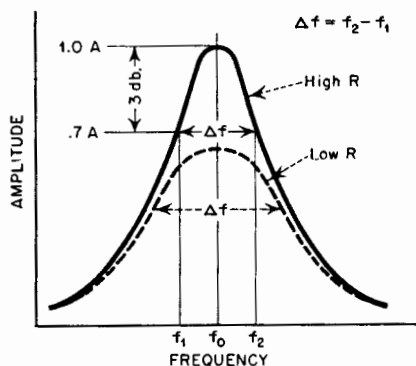
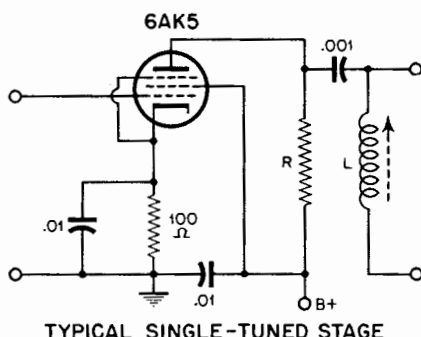
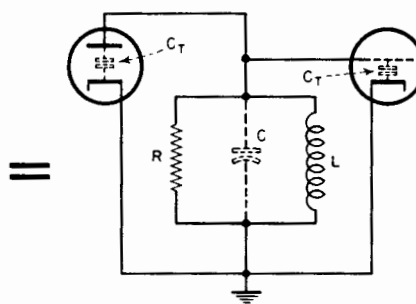

FIG. 1



TYPICAL SINGLE-TUNED STAGE



A.C. EQUIVALENT

FIG. 2

each 4 megacycles broad at the 3 db. point, when cascaded would thus have an overall band-pass of only 1.75 megacycles. This is evident from the fact that if the voltage gain at the center frequency ( $f_0$ ) is 10, the gain at the 3 db. points is only 7.07. Upon amplification by a second identical stage, the gain at  $f_0$  is  $10 \times 10$  or 100, while the gain at the former 3 db. points is now only  $7.07 \times 7.07$  or 50, which is 6 db. down in voltage. The bandwidth at the 3 db. points has been reduced to 64% of that for the single stage. Further amplification by similar stages would result in the overall bandwidth being reduced to 51% for a third stage, 44% for a fourth stage, 39% for the fifth, etc.

In addition to the undesirable feature of rapidly decreasing pass-band for multiple stages, the synchronously single-tuned system does not satisfy the requirements of the television video i.f. since it is incapable of producing the flat-topped response curve required for picture reproduction. The shape of the video i.f. response which is accepted as the standard in television practice is shown in Fig. 3. An essentially "flat" band-pass of nearly 4 megacycles is required for high-definition picture reproduction on large-screen cathode-ray tubes, although sets using small tubes may get along with much less. The gradual, nearly linear decrease in the response at the picture-carrier end of the curve is intended to compensate for the presence in the transmitted signal of the first 1.25 mc. of the lower side-band. (The rest is suppressed at the transmitter). When the picture-carrier i.f. frequency is aligned to the mid-point of this slope, the small portion of the vestigial lower side-band which is under the response curve is compensated for by the omission of a similar area from the lower 1.25 mc. of the upper side-band. Therefore, the response to the lower video frequencies is made nearly equal to the higher ones, although derived partially from both upper and (vestigial) lower transmitted side-bands.

Considerable improvement over the performance of synchronous single-

tuned amplifiers may be obtained by the use of multiple-tuned circuits. In a double-tuned, transformer-coupled stage such as is shown in Fig. 4, the coefficient of coupling ( $k$ ) and the primary and secondary circuit  $Q$ 's may be adjusted so that the response curve is essentially flat topped. Such maximally flat or "transitional" coupling occurs when the circuit  $Q$ 's and the coefficient of coupling are related as shown in Fig. 4. The term "transitional coupling" is derived from the fact that the coupling is adjusted to the point of *transition* between the single and double-humped response curve. It will be recalled that, as the coupling coefficient of the tuned transformer is increased from a very small value, the curve of secondary current versus frequency changes from a small sharp peak when the circuits are under-coupled, to a broad double-peaked response when the circuits are over-coupled. (Dotted lines, Fig. 4). The coefficient of coupling of the inter-stage transformer may be determined by measuring the capacity values necessary to resonate the primary to a given frequency when the secondary is alternately open- and short-circuited. ( $C_0$  and  $C_s$  respectively.) Knowing the ratio of these capacities:

$$(4) \quad \text{Coefficient of coupling } (k) = \sqrt{1 - \frac{C_0}{C_s}}$$

At the value of  $k$  corresponding to critical coupling, the transfer of energy to the secondary is maximum and the curve is flat-topped. The response characteristic obtained in this manner is more nearly that required by the television video i.f. Furthermore, because of the more uniform response over the pass-band, the overall bandwidth does not decrease as rapidly when identical stages are cascaded as in the case of synchronous single-tuned stages. When two double-tuned, transitionally-coupled amplifier stages are cascaded, the output bandwidth is reduced to 80% of the width of an individual stage. The corresponding figure for synchronous single-tuned stages is 64%.

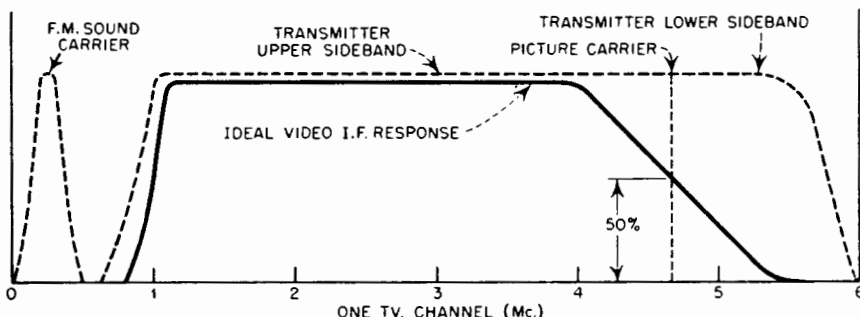
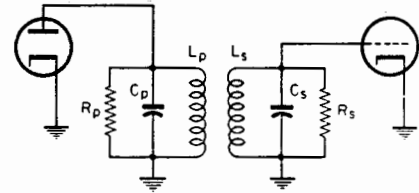

FIG.3



EQUIVALENT DOUBLE-TUNED CIRCUIT

When:  $Q_p = Q_s$

$$K = \frac{1}{\sqrt{Q_p Q_s}} \text{ for transitional coupling}$$

$$\Delta f = \frac{\sqrt{2}}{2\pi RC} \text{ where } C = \sqrt{C_p C_s}$$

$$R = \sqrt{R_p R_s}$$

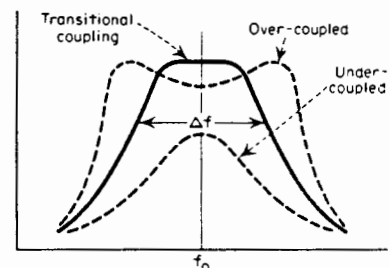

FIG.4

Further improvement in gain-bandwidth performance may be obtained by the use of more complicated inter-stage coupling networks. These include; double-tuned stagger damped, triple-tuned transformer-coupled, single-tuned inverse-feedback and complex filter-coupled stages. Most of these types are difficult to design and troublesome to construct and align, so will not be discussed here in detail.

One type of band-pass amplifier which does retain the simplicity of design and alignment of the synchronous single-tuned type, and yet overcomes most of its disadvantages, exists in the stagger-tuned amplifier. Wallman and others have shown that if the successive stages of a simple single-tuned amplifier are adjusted to slightly different frequencies (staggered) throughout the desired pass-band, the composite response curve may be made flat-topped and the gain high. Furthermore, the design work requires only high school math and a few simple tables, the construction done with common tools and the alignment may be accomplished in a few minutes with the aid of a spot-frequency signal generator and an output meter. The double-tuned and other more complex types previously mentioned require the use of a swept-frequency signal generator and an oscilloscope. Stagger-tuned systems are being used extensively in commercial television practice.

Since the individual stages of the stagger-tuned amplifier are merely the single-tuned type shown in Fig. 2, the design equations (2) and (3)



• STAGGER-TUNING TABLE •		
$\Delta f =$ Required overall bandwidth, $f_0 =$ Center frequency, $d = \frac{\Delta f}{f_0}$		
NUMBER OF CIRCUITS	CIRCUIT FREQUENCY	CIRCUIT BANDWIDTH
Staggered - pair	$f_1 = f_0 + .35 \Delta f$	$.71 d (f_1)$
	$f_2 = f_0 - .35 \Delta f$	$.71 d (f_2)$
Staggered - triple	$f_1 = f_0$	$\Delta f$
	$f_2 = f_0 + .43 \Delta f$	$.5 d (f_2)$
	$f_3 = f_0 - .43 \Delta f$	$.5 d (f_3)$
Staggered - quadruple	$f_1 = f_0 + .46 \Delta f$	$.38 d (f_1)$
	$f_2 = f_0 - .46 \Delta f$	$.38 d (f_2)$
	$f_3 = f_0 + .19 \Delta f$	$.92 d (f_3)$
	$f_4 = f_0 - .19 \Delta f$	$.92 d (f_4)$
Staggered - quintuple	$f_1 = f_0$	$\Delta f$
	$f_2 = f_0 + .29 \Delta f$	$.81 d (f_2)$
	$f_3 = f_0 - .29 \Delta f$	$.81 d (f_3)$
	$f_4 = f_0 + .48 \Delta f$	$.31 d (f_4)$
	$f_5 = f_0 - .48 \Delta f$	$.31 d (f_5)$

TABLE II

which were presented in connection with the synchronously tuned amplifier may be used. These, used in conjunction with the table of stagger-tuning and bandwidth factors shown in Table II (after Wallman) and a method of cutting the coils to resonance, are all that are needed to complete the design.

To illustrate the method of procedure, suppose that a video i.f. amplifier using 6AK5 pentodes is to have a uniform gain of 75 db over a bandwidth of 4 mc. centered at 24 mc. Referring to Table I it is seen that the 6AK5 has a gm of 5000 micromhos and the total interstage capacity may be limited to 11 mmf. The gain-bandwidth product (Eq. 3) then becomes  $5000/6.28 \times 11$  or 72.4 megacycles. If this stage "figure of merit" is divided by the required overall bandwidth of the amplifier, the result (18.1 or about 25 db.) is the mean stage gain available using 6AK5's. Therefore, three stages, properly staggered should be capable of providing the specified 75 db. gain. Table II gives the value of frequency and bandwidth to which each of the four

coupling networks associated with the three stages must be adjusted to form a flat staggered-quadruple. In this example, the factor  $d$ , which is equal to the bandwidth divided by the center frequency, is  $4/24 = .166$ . Using this figure in Table II indicates the four circuits should be stagger-tuned to: 24.76, 23.24, 25.84 and 22.16 megacycles with the bandwidths adjusted to; 3.77, 3.56, 1.63 and 1.39 megacycles, respectively. Knowing the required bandwidths and the value of total C per stage, the values of the needed loading resistors may easily be found from the equation for the bandwidth of a single-tuned stage (Eq. 2). Solving for R in this equation yields values of 3845, 4060, 8900 and 10,400 ohms, in the order of decreasing bandwidth. In practice, the next higher standard values of resistance may be used, since other tube and circuit resistances are in parallel with the loading resistors and lower the total effective value somewhat. The inductances required to resonate with 11 mmf. distributed circuit capacitance at the above stagger-frequencies may be determined by the use of a

reactance calculator, a "Q Meter" where available, or by empirical formulas. Since additional capacitance is very detrimental to the gain-bandwidth product of the stage, the coils should be self-resonant with the circuit capacity or tuned with high quality powered-iron slugs.

When resistors and inductors corresponding to the values determined for R and L are inserted in typical single-tuned stages such as that shown in Fig. 2, and these stages are connected in cascade, the resulting stagger-tuned amplifier is non-critical to adjust and will compare favorably with more complex types in performance. The overall gain-bandwidth product is better than a synchronously tuned amplifier of the same number of stages by a factor greater than two. Alignment is accomplished by connecting a standard AM signal generator to the input of the amplifier and an amplitude indicating device such as a voltmeter to the output. The signal generator may then be set to the recommended stagger frequencies in succession and the individual stage corresponding to that frequency peaked for maximum output response. Due to the isolating action of the tubes, there is virtually no interaction between stages while tuning. This is in sharp contrast to the procedure with double-tuned or triple-tuned circuits. In this case, a swept-frequency signal source and an oscilloscope must usually be connected to the input and output (respectively) of each stage in succession and the coupled circuits tuned and retuned until the desired response is observed on the 'scope. If adjacent-channel and sound carrier frequency "traps" such as are found in most television video i.f. amplifiers are incorporated in the single-tuned system, some slight tuning interaction may be noted.

## Cathode-Ray Tube High-Voltage Supplies

THE widespread use of the cathode-ray tube in television viewers and in test instruments has occasioned the use of high-voltage, direct-current supplies of rather unconventional design. Such departures from the standard 60-cycle power supply are due to the special requirement of 'scope tubes for accelerating voltages ranging up to 30,000 volts at current drains less than one milli-

ampere. The production of such voltages by line-frequency, iron-core transformers is impractical because the process of winding high-voltage secondaries with extremely fine wire is expensive. The problem of maintaining adequate insulation between the secondary and the other parts of the transformer is also troublesome. In addition, the network required to filter the low ripple-frequency is dan-

gerous and bulky. For these reasons, the use of this type of supply for high potentials has been virtually superseded by the more modern high-frequency supplies.

There are three general types of special high-voltage, low-current supplies in common use for cathode-ray tube applications. In the order of popularity, they are;

- (a) The Flyback, or "Kick" Supply.
- (b) The Radio-Frequency Supply
- (c) The Pulse-type Supply.

Each of these types has special advantages with respect to the requirements of economy, efficiency, compactness, ease of construction, and lack of interference with other circuits. We will presently discuss the operating principles and relative advantages of each type.

### The Flyback Supply

The high-potential supply most widely used in television sets having magnetic deflection systems is the horizontal return-sweep, or "flyback" supply. The popularity of this arrangement is due to the fact that it requires the least number of additional parts and it functions during the retrace period during which the picture-tube beam is blanked out. In this manner, the interference which may be caused in adjacent circuits is not visible in the television picture. This type of supply also requires no additional source of power, since it uses energy from a "transient" voltage in the horizontal sweep circuit which would otherwise be wasted.

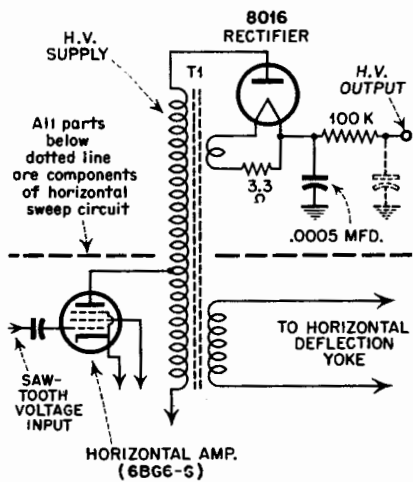

TYPICAL FLYBACK H.V. SUPPLY  
FIG. 1

A typical high-voltage supply of the flyback, or "kick", variety is shown schematically in Fig. 1. This circuit makes use of the fact that a high-voltage pulse of short duration is developed across the primary winding of the horizontal deflection transformer during the flyback period of the saw-tooth current pulse which is generated in the plate circuit of the horizontal amplifier tube. The amplitude of this inductive voltage surge is expressed approximately by:

$$\text{Voltage (e)} = L \frac{di}{dt}$$

Where: L is the primary winding inductance.

$\frac{di}{dt}$  is the time rate of change of current or the slope of the current saw-tooth.

Thus, it is seen that the amplitude of the voltage "kick" developed depends upon the inductance of the transformer primary winding and the rapidity with which the current flowing through it is changing. Since the current in the transformer builds up during the sweep period of about 57 microseconds, and collapses rapidly during the flyback time of approximately 7 microseconds, the rate of current change, and hence the induced voltage, is more than eight times greater during the retrace period. This inductive voltage "kick" is further stepped-up by a third winding on the horizontal deflection transformer which is connected with the primary to form an auto transformer. In addition to the high-voltage rectifier and filter circuit shown in Fig. 1, this special horizontal deflection transformer having a tertiary winding for the high-voltage supply is the only extra component needed for the flyback supply, since all other parts are standard components of the horizontal deflection system. The transformer, T1 in Fig. 1, is of special pulse-transformer construction. The windings are assembled on a core built up of very thin laminations or a special low-loss molded iron powder core.

### The Rectifier and Filter Circuit

The type of high-voltage rectifier and direct-current filter used with the

flyback supply is also practically standard for the other types of high-potential supplies to be discussed. For this reason, these components will be discussed in some detail here.

To rectify the high-voltage alternating or pulse wave, a specially designed diode rectifier tube is almost universally used. This tube, designated the 1B3-GT/8016, is rated at 33 kilovolts maximum peak inverse voltage. Maximum diode current is rated at 2.2 milliamperes. The special low-drain filament requires only 1.2 volts at 200 milliamperes for heating. This low filament power consumption feature of the 8016 rectifier, (less than one-quarter watt) enables the tube to be heated directly from the source of high-frequency energy. The filament circuit is inductively coupled to the high-voltage step-up transformer by means of a one- or two-turn link, as indicated in Fig. 1. A 3.3 ohm resistor is sometimes used in series with the filament circuit to protect the tube from burnout in case of over-coupling. The low-voltage link coupling feature of the 8016 facilitates isolating the rectifier filament circuit, which is operated at full output voltage above ground.

The design of the smoothing filter used with all modern types of high-frequency supplies is greatly simplified because of the low current requirement and the high ripple-frequency used. In the "kick" and the pulse-type supplies, the operating frequency is the same as the horizontal sweep frequency of 15,750 c.p.s. In the r.f. supply, the frequency of operating is usually above 50 kc. When such high-frequency waves are rectified, the resulting high ripple-frequency can be filtered by relatively small filter components. The high capacity filter capacitors and heavy iron-core chokes necessary in the usual 60-cycle filter section are replaced by a simple high-frequency filter consisting of a .0005-microfarad condenser and a low-wattage resistor. The output capacitance of this filter, shown by dotted lines in Fig.

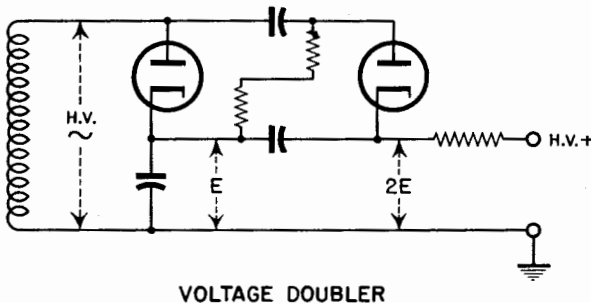

VOLTAGE DOUBLER

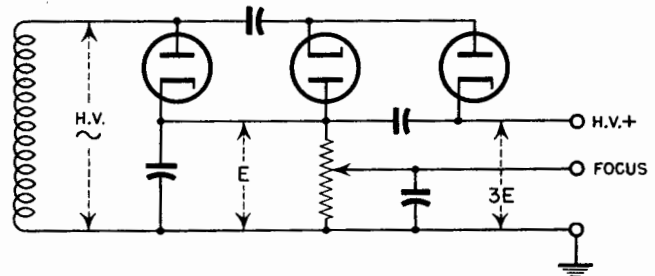
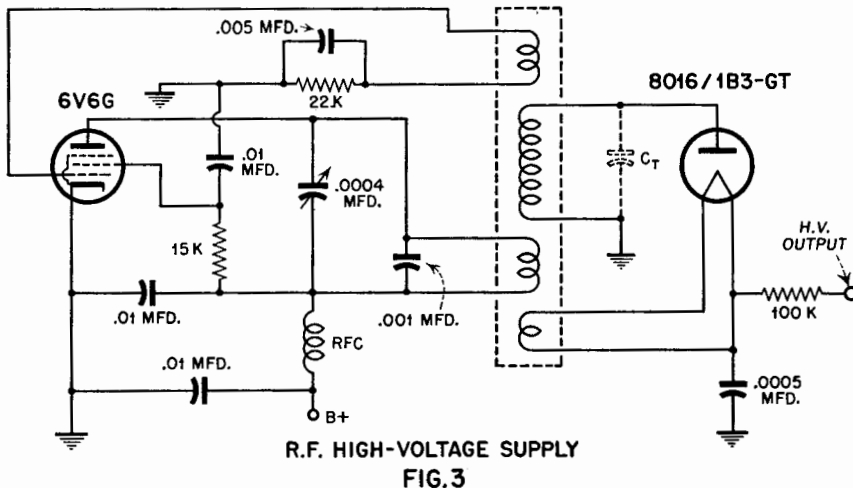

FIG. 2

VOLTAGE TRIPLER



R.F. HIGH-VOLTAGE SUPPLY  
FIG. 3

1, frequently consists only of the conductor-to-shield capacity of the high-voltage output cable.

Because of the low storage capacity of this filter design, the high-frequency supply is much less dangerous to operating personnel than a line-frequency supply using a "brute force" filter.

Voltage doubling and tripling arrangements are frequently resorted to in high-frequency supplies to obtain higher potentials, or to provide convenient taps for intermediate voltages. Fig. 2 illustrates some representative voltage-multiplying circuits. It will be noted that the techniques used are similar to those practiced with conventional line-frequency power supplies.

### The Radio-Frequency Supply

The basic circuit of the radio-frequency type of high-voltage supply is shown in Fig. 3. In this arrangement, the r.f. output voltage of a class C self-excited oscillator is transformed to a very high value by a tightly coupled, double-tuned, step-up transformer. Since the frequency of operation may be between 50 to 200 kilocycles per second, the voltage step-up is accomplished by a lightweight, economical, air-wound transformer.

The power oscillator usually consists of a beam pentode of the 6V6 or 6L6 type, used in a tuned-plate, grid-feedback circuit. Class C operation is used for high efficiency. Anode voltage ranging from 250 to 400 volts d.c. is applied to the oscillator tube, depending on the type used and the high-voltage value required. In applications where accelerating potentials as high as 27,000 volts are required for projection television kinescopes, two or more oscillator tubes

as large as the type 807 may be operated in parallel.

The step-up transformer which couples the r.f. oscillator to the rectifier and filter circuit is designed to fulfill several special requirements. It must be sufficiently insulated between the primary and secondary windings to withstand the full output voltage

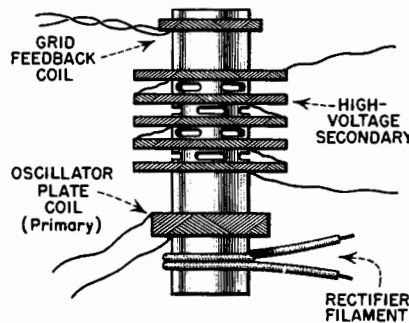

TYPICAL R.F. SUPPLY TRANSFORMER CONSTRUCTION  
FIG. 4

and yet these windings must be tightly coupled to provide efficient energy transfer. It must dissipate considerable heat and must be designed to minimize stray current leakage. The secondary winding must have a high Q when resonated at the operating

frequency with the distributed capacity of the wiring and rectifier tube. Windings for the rectifier filament and grid-feedback "tickler" must also be provided.

Fig. 4 shows a typical r.f. supply transformer design. The coil form is usually of thin-walled, impregnated bakelite tubing of low power factor. To decrease leakage currents between windings, and to facilitate the free circulation of air for cooling, a series of long circumferential slots is made in the coil form, as shown in Fig. 4. The primary, secondary, and grid-tickler windings are wound with Litz wire to minimize losses. The high-voltage secondary is made up of universal-wound "pies", spaced sufficiently to prevent corona discharge between them.

The overall efficiency of the r.f. oscillator type of high-voltage supply is between 25 and 45 percent. Its principle disadvantage lies in the fact that sufficient harmonic radiation is sometimes present to cause interference with other circuits. Complete shielding and supply-lead filtering is therefore necessary.

### The Pulse-Type Supply

Although not enjoying the wide usage of the high-voltage supply types discussed above, the pulse-type supply is used in some applications. Like the flyback supply, the pulse generated is synchronized to occur during the blanking period of the horizontal sweep cycle, so that minimum radiation interference is caused in television sets. In common with the r.f. supply, it has the disadvantage of requiring additional component parts and power, but can be used for cathode-ray tubes having electrostatic deflection.

The circuit arrangement of the pulse-type high-potential supply is illustrated in Fig. 5. The essential parts consist of; a blocking oscillator pulse generator, a pulse amplifier stage, a step-up pulse transformer, and a rectifier-filter section similar to those used with supplies of the r.f.

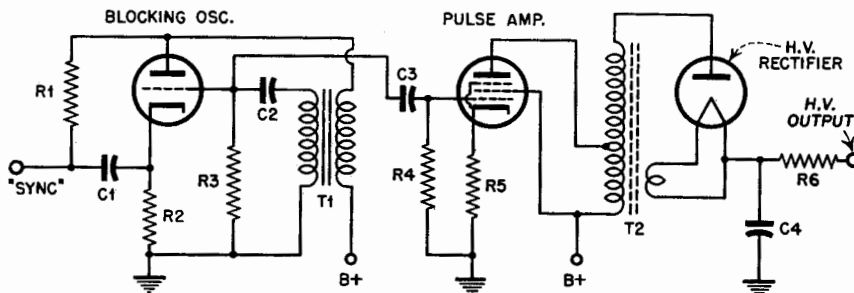

PULSE-TYPE H.V. SUPPLY  
FIG. 5

and "kick" types. As in the "kick" supply, the amplitude of the high voltage developed is dependent upon the rapid change of current flowing in the pulse transformer inductance during the pulse.

The pulse generated by the blocking oscillator is usually synchronized with the horizontal sweep so that it occurs during the 7 microsecond retrace period. Synchronization is effected by injecting horizontal sweep voltage into the blocking oscillator circuit at the point marked "Sync" in Fig. 5. The synchronizing voltage permits oscillation of the blocking oscillator, which is held normally inoperative by a bias voltage developed across the cathode resistor, R2. In addition to preventing picture tube "hash" by restricting the high-voltage pulse to the "dark", retrace period of the sweep, this system of synchronization also protects the kinescope from screen burning by holding the

high-voltage supply inactive in case of sweep failure.

#### Service Notes

In performing any operation on active high-voltage supply circuits, it must be remembered that **LETHAL VOLTAGES ARE PRESENT!** Although the poor over-load regulation of the high-frequency types renders them much less dangerous than the older 60-cycle supplies, direct contact with the voltages developed is extremely painful and can be fatal. Therefore, due caution should be exercised.

The trouble most frequently encountered with high-potential supplies is corona discharge from the high-voltage portion of the circuit. Corona, identified by a blue glow or brush discharge around the parts effected, caused erratic output voltage with attendant poor picture brilliance. It is caused by high voltage gradients

between adjacent parts, resulting in ionization of the surrounding air. To reduce corona effects, commercial supplies are designed with all components and conductors having large radius contours, since sharp corners or points aggravate corona discharge. For this reason, when working on high-voltage sources, care should be taken to avoid introducing high gradient points such as rough, sharp solder joints or sharp bends in wiring.

Actual current leakage on the surface or through insulation material is another problem in cathode-ray tube supplies. This effect tends to load the supply excessively and frequently results in complete breakdown and carbonization of the leakage path. In such cases, replacement of the defective part is the only effective remedy. Leakage can be reduced by preventing the formation of greasy, dusty films on the surfaces of insulating material.

## Television Interference Filters

**T**HE advent of television broadcasting has brought about many new problems in interference elimination. Much of this interference is caused by spurious radiations from transmitters of other services. The burden of finding solutions to such problems rests upon the licensee of the transmitter causing the interference, and upon the owner of the set being interfered with — or his service technician. Usually, a satisfactory solution can only be arrived at through the complete cooperation of all parties concerned.

The American amateur radio operator, because of greater numbers, closer proximity to owners of TV sets, has spear-headed the technical battle to find cures for this threat to his hobby. Now, with many "hams" again able to operate at full one-kilowatt input in the midst of dozens of TV receivers, the battle has been won. There remains only the job of educating others in the methods employed.

The most powerful tool which has been applied to the elimination of television interference (TVI) is the frequency selective filter. The application of filter networks to television interference elimination and the construction of practical filters for use at the source of

the interference, as well as at the TV set, will be discussed here.

#### Causes of Interference

Because of the lack of selectivity inherent in modern television receivers, they are particularly prone to interference by spurious signals of many kinds. When one considers that the minimum band-pass for tuned receiver "front-ends" is about 6 mc. and that many using untuned grounded-grid r.f. stages will accept signals over a band many times this width, it is seen why this is so. For example, an amateur transmitter operating at 7 mc. may radiate a small amount of power at each of the harmonics (multiples) of this frequency. The amplitudes of these harmonics diminish rapidly with frequency, but multiples up to the sixteenth or eighteenth may be of sufficient strength to interfere with a weak television signal, depending upon the proximity of the amateur transmitter and its adjustment. Thus, with a harmonic falling every 7 mc., the transmitter stands a good chance of interfering with TV channels 2, 3, 4, and 5, since the 8th through 11th harmonics of 7 mc. fall within them. The degree of interference is usually determined by the proximity of the harmonic to the frequency of the picture carrier. If

it is close, the harmonic must be weaker by about 50 db. to avoid interference.

By far the most serious harmonic interference is that caused by the second harmonic of "ham" stations operating in the 28 mc. band, since this harmonic falls directly in channel 2 and is usually quite strong. Another such case of troublesome interference is occasioned by the second harmonics of FM stations which fall within the high-band TV channels. The commercial solution to this problem has been similar to that adopted by amateurs — the use of filters to prevent spurious radiation.

TVI may also be caused by low-frequency signals getting into the receiver i.f. stages, either through the tuner or by direct pick-up in the set wiring. Cases have been observed where picture reception was prevented by signals from European short-wave broadcast stations leaking into the 21.25-25.75 mc. i.f. channel. This type of interference is usually characterized by the fact that all TV channels are effected, regardless of tuning.

#### TVI Reduction at the Transmitter

Of course, the most effective approach to interference elimination is to start at the source. The harmonic content of the transmitter signal is

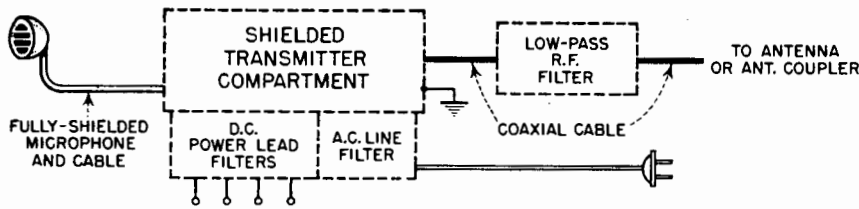

ILLUSTRATING USE OF COMPLETE SHIELDING AND FILTERING AT TRANSMITTER  
FIG.1

tremendously affected by circuit adjustments such as grid bias, grid drive, modulation percentage, and tank circuit L-C ratio. If the generation of harmonics and parasitics is first minimized by the selection of the proper values for these variables, the job of preventing the radiation of the remainder is considerably simplified.

In addition, it has usually proven necessary to completely shield the offending transmitter before the work of harmonic suppression by the use of filters can proceed. Otherwise, harmonic radiation may occur from the final tank coil and other parts of the transmitter. Since the wavelength of the harmonics which cause TVI are relatively short, leads of moderate length may act as efficient antennas.

The need for shielding may be determined by loading the transmitter with a "dummy" lamp-load substituted for the antenna. If the TVI clears up, it indicates that the interfering signal is being radiated by the antenna and that the present degree of shielding is adequate. If this test shows that more shielding is needed, the type required need not be elaborate, but must be complete. Commercially built metal cabinets, although neat in appearance, do not always provide effective shielding because of poorly-bonded joints, doors, cracks, and ventilating louvers. The most popular method of shielding employed in amateur practice is to enclose the entire transmitter r.f. chassis in a box made up of close-mesh copper screening, soldered at all junctions to make it absolutely r.f.-proof. This shielded chassis and

panel may then be mounted in a standard rack or cabinet to improve the appearance.

With the r.f. portions of the transmitter thus completely shielded, it becomes a relatively simple matter to filter all leads entering this metal enclosure, in the manner indicated in Fig. 1. It must be remembered that the key or microphone lead is a potential source of r.f. leakage and must be either shielded or filtered. Any a.c. power leads which enter the chassis must also be filtered. For this purpose, a balanced single pi-section, low-pass filter as shown in Fig. 2 may be employed. A unit of this type may be constructed in a small metal box and bonded solidly to the outside of transmitter shield box for maximum effectiveness. The line filter should not be assembled inside of the transmitter housing because of the danger of the components coupling to harmonics from the tank circuit.

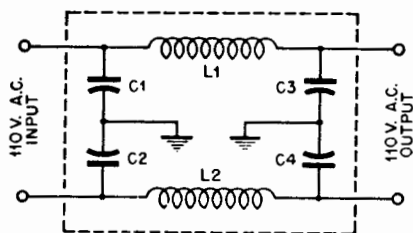

L1, L2 - 30T. No.12 E., 3/4" FORM  
C1, C2, C3, C4 - .005 MFD. MICA (Aerovox Type 1467)  
LOW-PASS LINE FILTER  
FIG.2

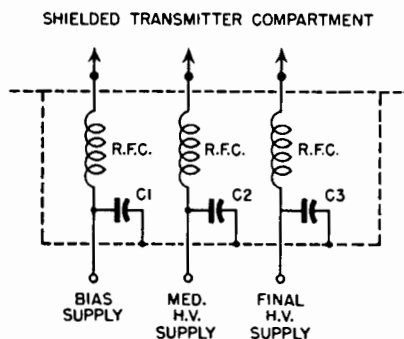

R.F.C. - 5 to 10 MICROHENRIES, V.H.F. CHOKE  
C1, C2, C3 - .001 to .01 MFD. (SEE TEXT)

SHOWING METHOD OF FILTERING TRANSMITTER D.C. LEADS  
FIG.3

For d.c. leads which enter the shielded compartment, a single L-section low-pass filter of the type illustrated in Fig. 3 has proven effective in preventing r.f. leakage. The values of the components are not critical, but they should be of high quality. Inductances should be of a universal-wound type so that distributed capacitance is reduced. Mica capacitors should be chosen, according to voltage requirements. A filter of

this kind should be used in each d.c. lead which might conduct r.f. out of the shielded housing. Like the line filter, these d.c. filters should also be assembled in a separate metal box which is fastened to the outside of the main shield compartment. A common housing may be used for all power lead filters.

After the job of shielding the transmitter and filtering all power leads has been completed, it should be checked again for TVI. If all signs of interference to nearby television receivers have disappeared when full transmitter power is applied to a dummy load *inside* of the shielded compartment under conditions of full modulation or keying, this part of the job is satisfactory.

If the interference appears when the antenna is again connected, the TVI is reaching the receiver by radiation from the antenna. It may be of the harmonic type or the receiver overloading type. At this point it is well to determine which, since further changes at the transmitter will not eliminate the latter type. The harmonic content of the transmitter signal may be checked by listening on the multiples of the operating frequency with a good VHF receiver, or by building a crystal "harmonic checker." The circuit of a simple device which fulfills this requirement is shown in Fig. 4. It consists of a parallel L-C circuit which tunes to the low TV frequencies and which is link coupled to a crystal rectifier and indicating meter. The tuned circuit must be calibrated in frequency so that harmonics may be identified. Several of the commercial absorption wavemeters may be used for harmonic checking by the addition of the crystal indicating circuit. Alternatively, a grid-dip meter of the type which has provisions for operating the oscillator tube as a diode detector may be employed for locating harmonics.

The harmonic checker should be loosely coupled to the output of the

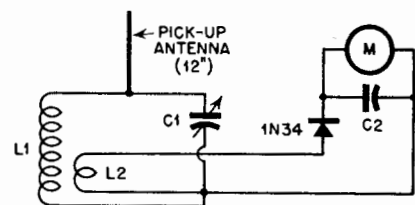

C1 - 25 MMFD. MIDGET VARIABLE  
C2 - 50 MMFD. (Aerovox Type 1468)  
L1 - 8T. No.12, 1/2" I.D. X 1" LONG  
L2 - 2T. No.18 D.C.C. WOUND OVER L1  
M - LOW RANGE CURRENT METER

CRYSTAL HARMONIC CHECKER  
FIG.4

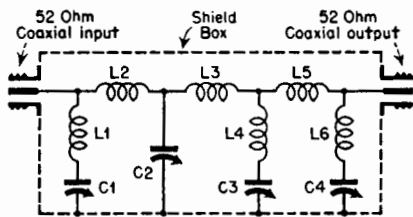

- C1, C4 - 41 MMFD. (50 MMFD. AIR PADDER)
- C2 - 136 " (150 " " " " )
- C3 - 106 " (150 " " " " )
- L1, L6 - 4 T. No. 12 E. 1/2" I.D. X 1/2" LONG
- L2 - 5 T. No. 12 E. 1/2" I.D. X 3/8" LONG
- L3 - 6 T. No. 12 E. 1/2" I.D. X 3/16" LONG
- L4 - 4 T. No. 14 E. 1/4" I.D. X 3/8" LONG
- L5 - 5 T. No. 12 E. 1/2" I.D. X 3/4" LONG

LOW-PASS TRANSMITTER FILTER  
FIG. 5

transmitter and a systematic search for spurious frequencies made. The sensitivity of the indicator will be better if a low range microammeter is used. The frequency of all signals detected, other than the carrier, should be carefully tabulated, since this information will prove of value in determining filter requirements.

If any radiation is detected in the television bands, a filter between the transmitter and the antenna is necessary. Ideally, this filter should be a unit which transmits the amateur frequencies without loss, while presenting infinite attenuation to all TV band frequencies. Actually, these conditions may be approached with modern low-pass filters of the "m-derived" type. With such networks of relatively simple design it is possible to obtain attenuations greater than 100 db. at all television frequencies. If high quality components are used, the "insertion loss" in the amateur bands below 30 mc. may be less than .2 db. In addition, the attenuation at any given frequency within the rejection band may be "peaked up" by special design. In this way, added attenuation may be provided at specific frequencies where harmonic output is greatest.

A practical low-pass filter for use with amateur transmitters is shown in Fig. 5. This network starts attenuating at 45 mc. and should provide over 65 db. attenuation at all frequencies above 55 mc. It consists of four sections; two series m-derived end sections, one constant-K type intermediate section with maximum rejection at infinite frequency, and one series m-derived intermediate section with maximum attenuation at 71.25 mc. The filter is designed for use with shielded coaxial transmission line having 52 ohms characteristic impedance. The problems associated with transmitter

shielding and output filtering are appreciably simplified if shielded cable is used.

The filter is assembled in a suitable metal shield can having a tight-fitting cover. The transmission line enters the filter box through coaxial cable connectors which are soldered solidly to the metal box for perfect shielding. The lay-out of the parts is approximately as indicated in the schematic (Fig. 5). The capacitors are small air-padders which have sufficient spacing for the power to be handled. They should be adjusted to the capacitance values indicated in Fig. 5. All coils are self-supporting and must be kept one diameter away from other metal objects to insure accurate inductance values. The coil lengths specified in Fig. 5 are measured between the ends of the first and last turns. Lead lengths should be limited to about one-half inch.

The completed filter should be tested for proper functioning. A rough check may be made by exploring the frequency range near the intended cut-off frequency by means of a signal generator coupled to the input of the filter and an indicating device coupled to the filter output. If sufficient output is available from the signal source, a 50 ohm terminating resistor may be placed across the filter output and the power in it monitored with the crystal harmonic checker. The power transmitted through the filter should drop very abruptly at 45 mc.

#### TVI Reduction at the Receiver

A transmitter of another service may cause television interference even though its signal is in accordance with the best engineering practices. If it is located in the immediate vicinity of the TV set, as is usually the case with amateur transmitters, it may produce picture interference by overloading the TV receiver front-end and so produce local harmonics. This, of course, is not the fault of the transmitter, be it amateur or commercial. It is merely a consequence of the close spacing between the transmitter and the receiver, and of certain deficiencies in the TV set front-end design. Most receivers now incorporate one or two high-pass filter sections between the antenna terminals and the first r.f. or mixer stage. This filter is intended to prevent the passage of strong, low-frequency signals into the tuner, but to accept the TV signals.

In many cases, where the TV antenna intercepts a very strong low-

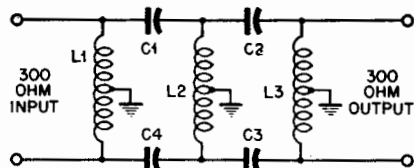

- C1, C2, C3, C4 - 20 MMFD. MICA (Aerovox Type 1469)
- L1, L3 - 23 T. No. 24 E., 3/16" I.D. CLOSE WOUND
- L2 - 11 T. No. 24 " " " "

HIGH-PASS FILTER FOR TV RECEIVER  
FIG. 6

frequency signal, the built-in high-pass filter may not provide adequate attenuation to prevent interference of the "overloading" type. It usually becomes the responsibility of the TV service technician to diagnose this trouble and to provide a cure. For this purpose several additional sections of high-pass filter may be necessary. Such filters are available commercially or may be made up. A typical design is detailed in Fig. 6. This filter is a balanced configuration for 300 ohm "twin-lead" and is of the double pi-section type. It is designed to have a high-pass cut-off at about 53 mc. so as to provide maximum attenuation to all amateur frequencies up to the ten-meter band (30 mc.).

The high-pass receiver filter should be constructed in a metal box similar to that described for the low-pass transmitter filter. Complete shielding is not too important in this case, since unshielded transmission line is used. High quality components should be selected. The capacitors should be of the silvered mica variety. Two 10-micromicrofarad units may be used in parallel to form the required capacitance value and to minimize lead inductance. The coils are close-wound on a three-sixteenth inch low-loss form and are center-tapped by twisting a half-inch loop in the center turn of each. These loops are then tinned and soldered to ground, leaving a quarter-inch lead. All coils should be mounted at least one inch apart to avoid coupling.

Receiver interference of the "i.f. channel" type mentioned above will also be reduced by the high-pass filter if it is being picked up by the antenna. However, interference of both this type and the "overloading" type may gain access to the receiver through the power line, or by exposed wiring in the receiver. In such cases, a low-pass line filter of the type shown in Fig. 2 should be used. It may also be necessary to improve the receiver shielding by adding a bottom plate to the chassis.

# Television Reception at "Shadowed" Locations

ONE of the most prevalent problems confronting the rural TV viewer and his service technician is that of providing reception at receiving sites well within the normal service range of one or more transmitters but "shadowed" by topographical details. In hilly or mountainous terrain, many communities and, indeed, whole cities, are in the vexing position of having strong, steady television signals going by a few hundred feet overhead, but with little or no signal available to antennas of practical height in the valley. A typical situation of this kind is depicted in Fig. 1.

The social and economic implications of this common situation are many and seem a high price to pay for a wrinkle on the surface of the earth formed long before anyone had television transmission in mind. To the viewer, it means missing out on the educational and entertainment miracle of television. To the TV dealer and serviceman it means whole fields of potential set sales and servicing lying fallow. And, of course, to the television broadcaster and advertiser, it means reduced coverage. The following paragraphs are devoted to a discussion of some of the solutions which have or might be resorted to in such instances.

There are several approaches which might be used in "illuminating" a television receiver or community situated as in Fig. 1. They include:

- (a) A booster station located on the hill top at "A" and relaying the signal on the same frequency.
- (b) A satellite station situated at "A" rebroadcasting the signal on another frequency, such as a UHF channel.
- (c) A "passive relay" antenna at "A" receiving the television signal and re-radiating it into the valley.
- (d) A community antenna located on the hill top with a transmission line distribution system feeding receivers in the valley.

In evaluating the applicability of these approaches to specific locations, there are many legal, economical, and technical factors to be considered. We will now examine some of these.

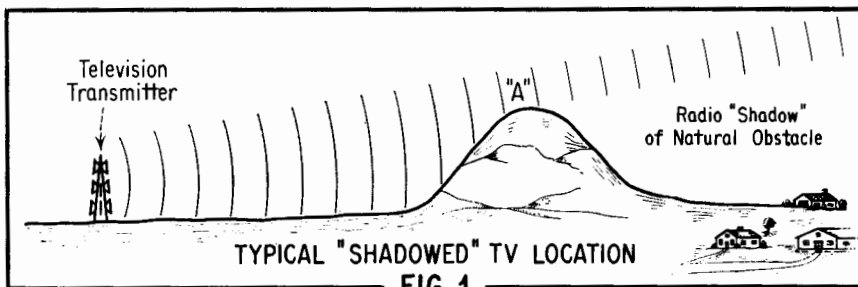

## The Booster Station

The operation of a relay transmitter modulated by the distant TV station involves considerable legal and technical complication. Legally it would require a license by the Federal Communications Commission as well as an agreement with the television station whose programs were to be relayed. It also requires a source of electrical power at the relay station site as well as frequent or continuous attendance. In general, the expense involved makes this the type of endeavor which must be financed on a commercial basis, rather than run as a community enterprise. Nevertheless, experimental booster stations of this kind have been authorized by the F. C. C.

The block diagram of a typical equipment lay-out required by a booster station is given in Fig. 2. A high gain receiving antenna oriented to receive the signal of the desired TV station, to the exclusion of any other on the same channel, feeds a low-noise r.f. amplifier. This drives a linear power amplifier which builds the signal up to the level required

for re-radiation by a second antenna oriented to illuminate the desired coverage area. For single channel relaying, the bandwidth of the overall system must be at least six megacycles. The total system gain will depend, of course, upon the signal strength available from the master station. In "fringe" areas, at least 100 decibels of overall gain must be provided if the coverage angle is large. Usually the power fed to the transmitting antenna need only be a few watts.

One of the technical difficulties encountered in the operation of a booster re-radiating on the same channel as the master station is that of feed-back. Enough isolation must be provided between the output and input to prevent such regeneration. This is usually accomplished by utilizing antennas with high front-to-back ratios placed back-to-back. Additional isolation is also available by placing the receiving antenna and associated low-level preamplifier equipment a few hundred feet from the power amplifier and transmitting antenna. A high grade coaxial cable is used to interconnect the two.

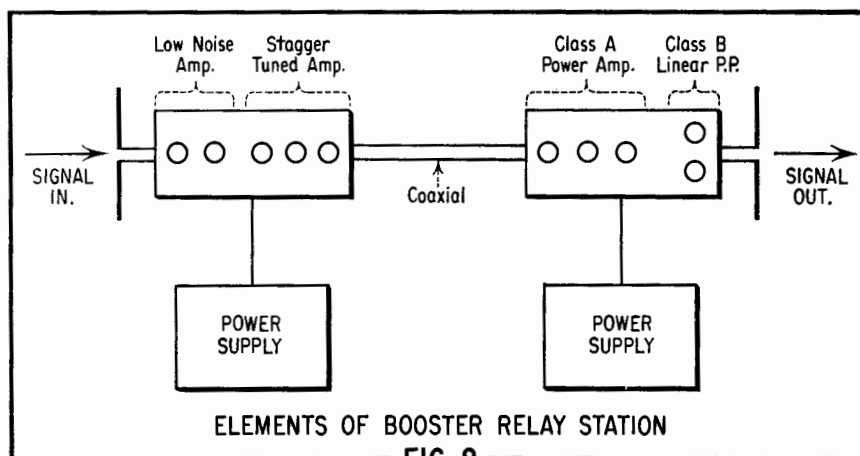

### Passive TV Relaying

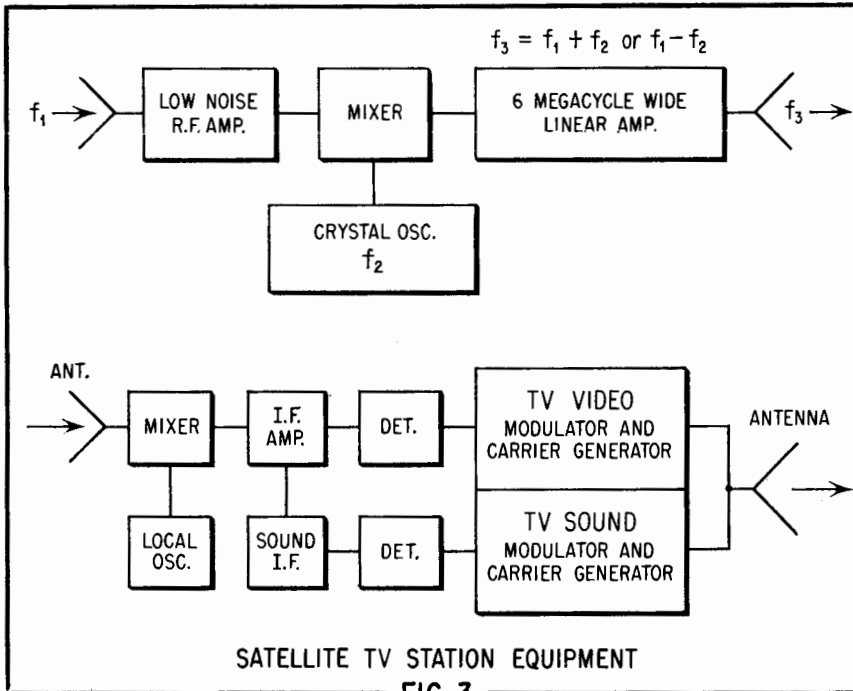

FIG. 3

One economic factor in favor of the booster approach is the fact that no expensive frequency control and sweep generator standards are required. Since the booster station is essentially a linear amplifier, all of the standards are established by the master station. Thus, the cost of an installation of this type is much less than that of a small station capable of originating programs, but is still prohibitive for the isolated viewer or small community.

#### Satellite Stations

Relaying the television signal on another channel frequency, such as a UHF channel, is even more complicated than same-channel relaying in many respects. In addition to requiring FCC authorization and master station permission, considerably more equipment is needed. Since the only

manner in which the channel frequency can be changed is by heterodyning the master station carrier to a new frequency or by modulating a locally generated carrier on the new frequency with the video signal of the master station, facilities for maintaining the required frequency stability will be required in either case. On the other hand, the problem of input-output isolation is eliminated in a relaying system of this kind, since the frequency transmitted is different from that received from the master station. The satellite station can be arranged to select any one of several master station signals available and relay them on the allocated frequency.

Block diagrams of two possible equipments for satellite station relaying are shown in Fig. 3.

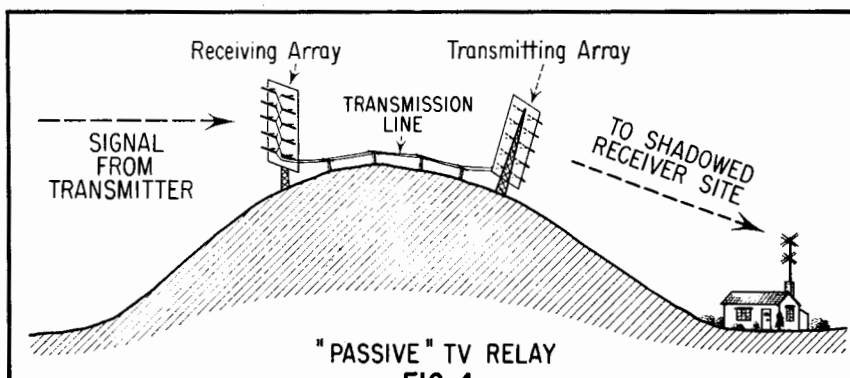

FIG. 4

Another interesting possibility for television relaying in locations where a strong signal from the master station is available might be called "passive" relaying. The essentials of this scheme are illustrated in Fig. 4. A high gain antenna situated on a high place within line-of-sight of both the transmitter and the shadowed receiver sites receives the signal from the TV station and feeds it to another high-gain antenna oriented to re-radiate the signal into the valley. This system has proven practical in several instances. It has many advantages over the foregoing systems which put it within the reach of the single isolated receiving site or the small community.

Since this system is totally "passive", i. e., does not employ amplifying or transmitting equipment of any kind, F. C. C. approval has not been required. For the same reason, no source of electrical power is required at the relaying site and a minimum of maintenance is necessary. These are decided advantages since the sites which are suitable for relaying of this kind are usually quite inaccessible. Another advantage offered by the passive antenna system is that of multi-channel operation. If several strong stations are located in the same direction, it will usually be possible to relay all of them simultaneously. In general, multi-channel installations will require the use of more elaborate antenna arrays, however.

If the site available for relaying is sufficiently large the rhombic antenna offers high gain and broadbanded operation while involving little expense. It can be constructed of wire, as contrasted to the more expensive aluminum tubing required in some other high gain designs. If the site is wooded, trees can usually be pressed into service to support the corners of the rhombics. Because the radiation pattern of a large rhombic is rather sharp, care must be taken to properly align both the receiving and the transmitting antennas. The major lobe of the rhombic is usually tilted a few degrees above the plane of the antenna. For this reason, it might be convenient to place the two antennas on opposite sides of the obstructing hill and interconnect them with a low-loss, high-impedance transmission line. Fig. 5 shows the dimensions of a rhombic antenna design which would be suitable at some locations. The gain of the rhombic increases with the number of wavelengths per leg.



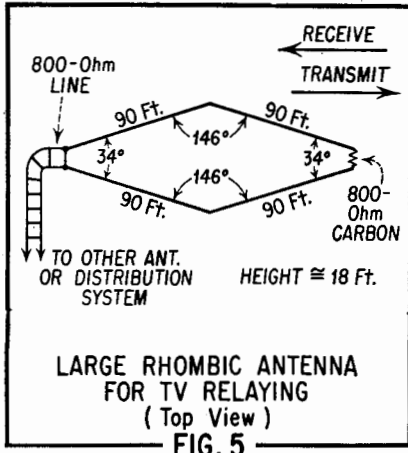

Another antenna type which could be used is the "chicken-wire horn" illustrated in Fig. 6. This design provides all-channel operation and reasonably high gain while requiring less space than the rhombic. Two such antennas could be used back-to-back at the crest of the hill or separated by some distance and connected with 300 ohm line. Of course, the length of the line should be kept to a minimum since its losses detract from the gain provided by the antennas.

Other high gain TV antenna designs could be utilized for passive relaying. In instances where only single channel operation is desired, multi-element stacked Yagi designs, cut for the proper frequency will provide good gain and directivity in small space. Antennas of the "billboard" type should also be useful.

In the choice of the transmitting antenna, attention must be given to

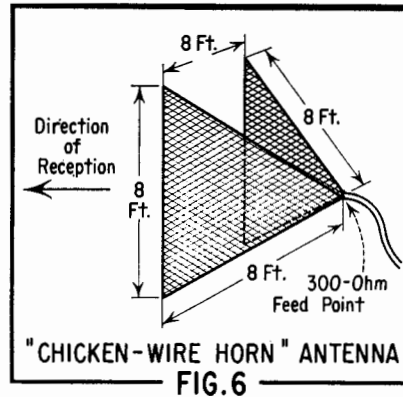

the angle of radiation. If the receivers are spread out over considerable area close to the re-radiating antenna, the pattern of this antenna must be wide enough to illuminate all of them. Since the object of the relaying system is to provide as much total system gain as possible, the antennas at the receiving sites must also be high gain designs of the variety usually employed in fringe areas. They, in turn, must be accurately oriented on the hill-top relaying antenna.

#### Community Antenna Systems

At locations where the receiving sites are only a few hundred yards from an elevated place where relatively strong television signals can be received, the community antenna scheme has been used successfully. As illustrated in Fig. 7, this system utilizes a high gain antenna on a high place and a long, low loss transmission line distribution system to "pipe" the signal to one or more receivers.

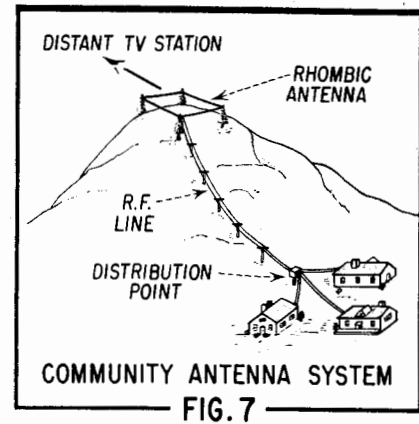

Technically, the problems associated with the community antenna approach are very similar to those involved in providing reception in large apartment buildings. The gain of the receiving antenna must be sufficient to off-set the losses of the feed line, and provisions must be made to isolate the various receivers to prevent interaction between them. Cathode-follower isolation stages or resistive isolation pads are usually employed for the latter purpose. Special attention must also be given to lightning protection in such installations, since an antenna on a high place is especially prone to such phenomena.

Low losses, consistent with economy, is the main factor to be considered in the choice of the transmission line between the hill-top antenna and the receiver distribution point. Special consideration should be given to the high impedance, open wire line and the surface wave transmission line. The cost of installation of the latter decreases with frequency, making it attractive for UHF use.

## SECTION II CIRCUITS

# Electronic Oscillators Part 1

IN the past 25 years of progress, probably no other basic electronic circuit has increased its scope and versatility as much as the vacuum tube oscillator. Practically every radio receiver contains at least one oscillator, and TV receivers normally contain three. Every transmitter must contain a carrier-generating and frequency-controlling oscillator, and special types (such as those employing single sideband output) employ several in many cases. The wide use of oscillators in test equipment, such as audio and radio frequency signal generators, frequency meters, grid-dip meters etc., and in magnetic recorders is well known.

The engineer, service technician, amateur and experimenter are thus vitally affected by the operation of oscillators in general, and important commonly used types in particular. The important fundamental concepts and design factors, and their application to every-day use of oscillators will be the objective of this discussion.

### *Definition of an Oscillator*

An oscillator is any device which can be induced into cyclic repetitive action. Mechanically, an example is the clock pendulum; its electrical counterpart is a tuned resonant circuit. In both cases, the period of each cycle, and thus the frequency of oscillation is controlled, but energy must be added to overcome the loss in the device if sustained oscillations are to be obtained. Since we are primarily interested in sustained oscillations without damping, a complete oscillator must have two main parts: a frequency-controlling device which is usually a resonant circuit, and another part which applies en-

ergy to the frequency-controlling device in the proper manner to sustain oscillation. The latter is usually an amplifier.

The Institute of Radio Engineers defines an oscillator as

A non-rotating device for producing alternating current, the output frequency of which is determined by the characteristics of the device. (Standards on Antennas, Modulation Systems and Transmitters, Definitions of Terms — IRE 1948.)

This definition is broad enough to cover all electrical oscillators. We are concerned here with the *electronic oscillator* which is an electrical oscillator employing one or more vacuum tubes.

An electronic oscillator requires input energy to overcome tube and circuit losses and to supply the required output power. This input energy it obtains by means of electrical energy or from the plate power supply, and indirectly from the heater or filament current to the tube. Basically, it can be considered a *converter* more properly than a generator, since it connects electrical energy from one frequency to another usually higher than the input frequency.

### *Negative Resistance Requirement*

For oscillation, energy must flow from the output (usually the plate) circuit to the input circuit (usually the grid) in such magnitude and phase as to overcome the losses of the system. But the basic amplifying action of a vacuum tube is to produce plate voltage which is approximately (exactly with a resistance load) 180 degrees out of phase

with the grid voltage which produces it. Part of this output voltage must be applied to the grid circuit in phase with the grid voltage. This is done by reversing the phase (either actually or effectively) of that part of the plate voltage fed back to the grid circuit.

When this condition exists the network develops a *negative resistance* in the circuit. In a negative resistance, the current increases as the voltage decreases; thus the current and voltage changes are out of phase 180 degrees.

There are three main ways in which a negative resistance can be provided in vacuum tube circuits for oscillation:

(1) By actually transmitting a desired portion of the output signal voltage to the input circuit in a feedback circuit which reverses the phase.

(2) By the design of a tube, or the adjustment of the applied potentials to the tube, so that it exhibits a negative resistance characteristic.

In this discussion, we will concern ourselves with the basic functional factors in types 1a and 1b. Type 2 will be considered later.

A—*Inductively*

B—*Capacitively, through the grid-plate capacitance or external capacitance*

### *Criterion For Oscillation*

In the consideration of any given oscillator circuit, it is important to know under what conditions of circuit design and adjustment oscillation will take place, as these conditions are limited.

For any oscillator of the feedback type, the Barkhausen criterion of Fig.

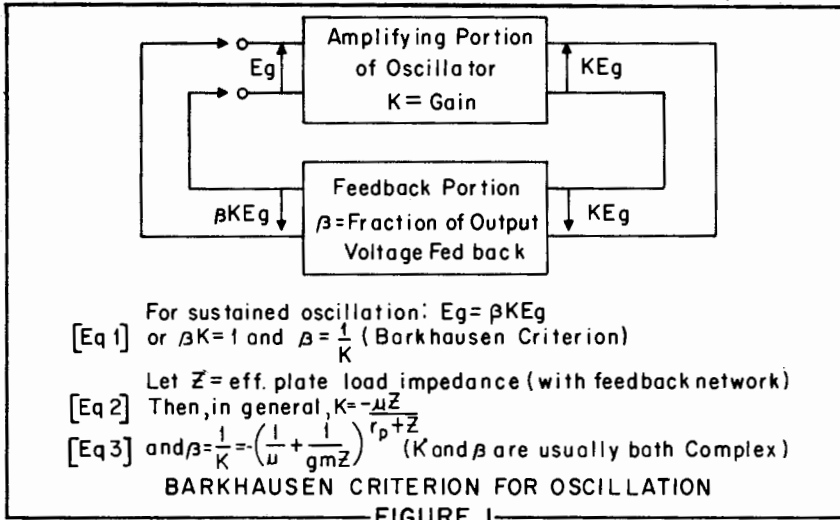

1 is applicable. This figure shows the oscillator broken up into its two basic parts, the amplifier and the feedback link. The input voltage to the amplifier  $E_g$  is the voltage fed back through the feedback circuit. This simple derivation shows that the fraction of the output voltage which is fed back ( $\beta$ ), must be equal to the reciprocal of the gain. Both of these factors are complex, because both the amplifier and the feedback circuits do, in general, introduce phase shifts. For oscillation, the phase shifts must cancel.

Equations 2 and 3 apply the criterion to a grounded-cathode amplifier. This expression is general, and can

be applied to any particular circuit by evaluating load impedance and  $\beta$  in terms of the circuit parameters involved and substituting them in the general expression equation 3.

**Inductive Feedback Circuits**

From a theoretical standpoint, probably the most direct method of providing negative resistance for oscillation is by mutual inductance between coils in the plate and grid circuits respectively. The two most common circuits of this type are illustrated, along with their equivalent circuits, in Fig. 2 and 3 respectively.

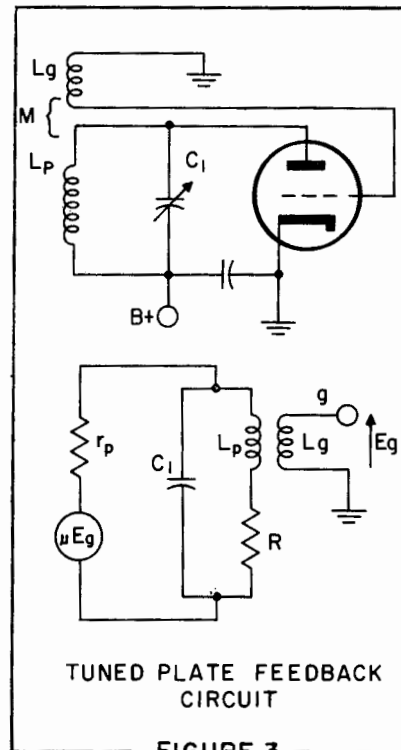
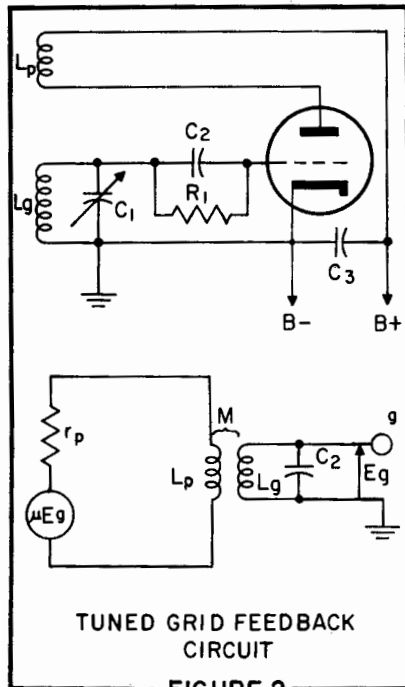

It will be noted that they differ only in the choice of which circuit is tuned.

These circuits can be analyzed either by setting up simultaneous equations equating the voltages around each loop, or by substituting appropriate expressions for  $Z$  and  $\beta$  in eq 3. For these circuits one method is about as easy as the other. The solution in each case results in an equation containing complex quantities. Equating the imaginary ( $j$ ) terms provides an expression for the actual frequency of oscillation compared to the resonant frequency of the tuned circuit. Equating the real terms gives a relation showing the conditions necessary for oscillation. The detailed steps of the analysis are available in the literature, and will thus not be repeated here. The results are as follows:

As might be expected, the expressions have similar forms for the two circuits. However, one interesting difference is that in the tuned grid circuit the frequency of oscillation is lower than the tuned circuit resonant frequency (Eq. 4) while in the tuned plate oscillator it is higher (Eq. 7).

**Tuned Grid Oscillator**

$$\omega = \frac{\omega_0}{\sqrt{1+A}} = \frac{1}{\sqrt{L_p C (1+A)}} \quad [Eq. 4]$$

$$M \approx -\frac{A}{1+A} \cdot \frac{L_p}{\mu} - \frac{CR}{gm} \quad [Eq. 5]$$

$$gm = -\frac{A}{1+A} \cdot \frac{L_p}{M r_p} - \frac{CR}{M} \quad [Eq. 6]$$

Where  $A = \frac{L_p R}{L_g r_p}$  and  $\omega = 2\pi \times$  actual osc freq  
 $\omega = 2\pi \times$  resonant freq of tuned circuit

**Tuned Plate Oscillator**

$$\omega = \omega_0 \sqrt{1 + \frac{R}{r_p}} = \sqrt{\frac{r_p + R}{L_p C}} \quad [Eq. 7]$$

$$M = -\frac{L_p}{\mu} - \frac{CR}{gm} \quad [Eq. 8]$$

$$gm = -\frac{L_p}{M r_p} - \frac{CR}{M} \quad [Eq. 9]$$

These frequency equations are useful primarily in a qualitative way; quantitatively since  $\omega$  is ordinarily very close to  $\omega_0$ , the values of  $L$  and  $C$  are usually adjusted at least partly

by empirical means, starting with values which by themselves resonate at the frequency of oscillation. But these expressions are important in indicating the direction of frequency change with change of  $Q$  and external loading.

In comparing the two circuits, the expression  $A$  is significant. Because the feedback "tickler" coil  $L_p$  in the tuned grid circuit is usually much smaller than  $L_g$  and  $R$  is very much smaller than  $r_p$ , the value of  $A$  is for less than 1. Because of the presence of the ratio of inductances in  $A$ , and the fact that the plate coil is normally much smaller than the grid coil in the tuned grid circuit, it will be noted that the frequency of this circuit is less sensitive to changes in  $R$  (and thus  $Q$ ) than in the tuned plate circuit. Also, in the expressions for  $M$  and  $g_m$ , the plate inductance appears in the numerator of the first fraction for both oscillators. Accordingly, since the plate inductance is relatively much smaller in the tuned grid circuit, the latter will oscillate with smaller values of  $M$  and  $g_m$  than will the tuned plate circuit.

In addition to the above-mentioned relative disadvantages, the tuned plate circuit requires of its designer that he make the unpleasant choice between (1) having plate d-c voltage applied to the coil and capacitor with series feed or (2) adding an r-f choke, with its added expense and danger of self-resonance somewhere in the tuning range, with shunt feed. On the other hand, in the tuned grid circuit, the plate coil is aperiodic, isolated from tuning adjustments, is easily insulated and adapts itself nicely to series feed, which is always used.

In defense of the tuned plate circuit, it should be said that it is less sensitive to power supply voltage variations. This arises from the fact that space-charge capacitance, a function of plate voltage, is greater between grid and cathode than between plate and cathode. The space-charge effect is thus greater upon the frequency-determining circuit is connected to the grid than when it is connected to the plate.

It is important to note some of the assumptions made in the derivation of the equations 4 through 9. First, the effect of rectified grid current, present in nearly all oscillators, has been neglected. The vacuum tube and its circuit has been considered as a linear device, whereas ordinarily it must be non-linear for oscillator operation. However, this is not too bad an assumption. Nowadays, the power oscillator is a thing of the past except in special applications,

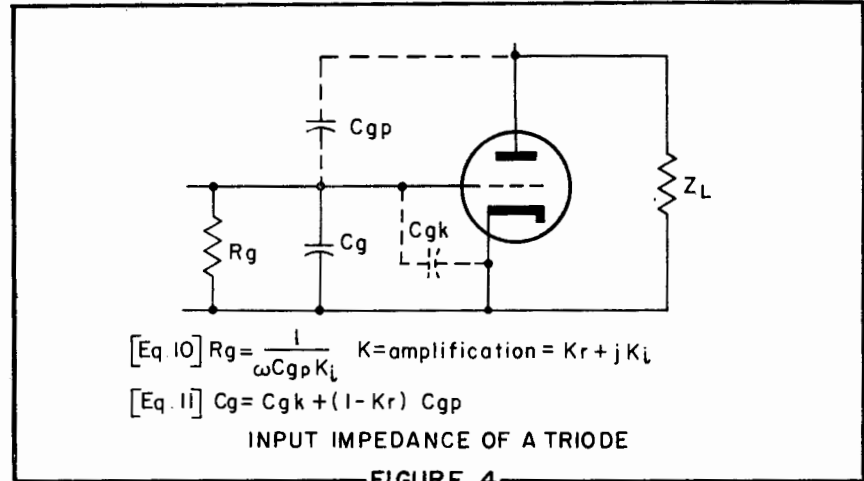

FIGURE 4

and the usual circuit is designed for stability and flexibility. For the attainment of the best stability, the grid current must be kept relatively low, making the equations nearly valid.

Another assumption in the analysis of the inductive feedback oscillators is that grid-plate capacitance is negligible. This is a reasonable assumption, since, although it does add a certain amount of loading effect to the input circuit, this capacitance does not materially affect the action of the inductively-coupled feedback.

In general, an advantage of inductively-coupled feedback oscillators is that  $M$  provides a convenient parameter for adjustment of operating characteristics by adjustment of the size of the feedback coil and its physical position. A general disadvantage in multi-range circuits is that band-switching is complicated by the additional coil terminals.

### Capacitive Feedback Circuits

Under certain conditions, a deliberate circuit feedback path is not necessary for the support of oscillations. One common instance of this is the regenerative effect, especially in triodes, of the grid-plate capacitance. This effect becomes evident upon examination of the expression for the input resistance of a triode. Figure 4 illustrates the input impedance, which includes, in general, both a resistive and a capacitive component. The values of these depend upon the nature and magnitude of the plate load impedance as well as the grid-plate capacitance. When the plate load is a pure resistance, the resistive component of input impedance becomes infinite and the input impedance becomes a pure capacitance. (Amplification  $K$  depending upon plate load impedance.)

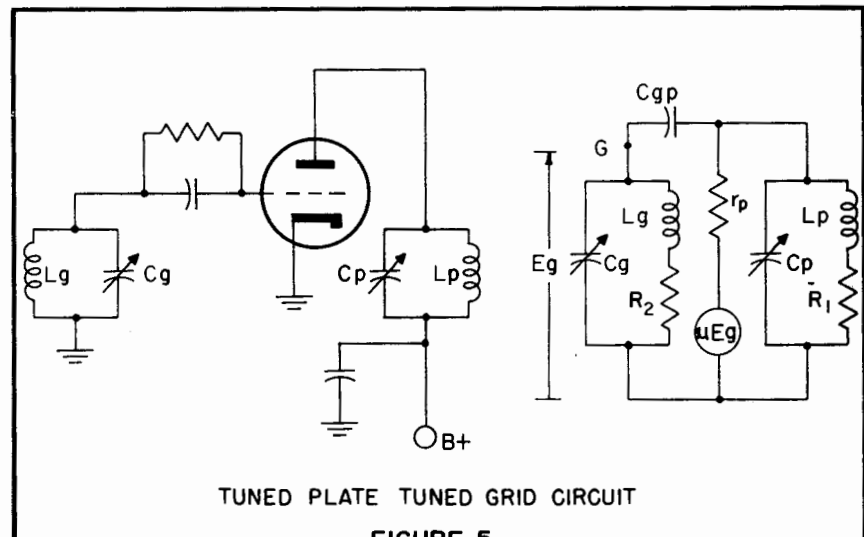

FIGURE 5

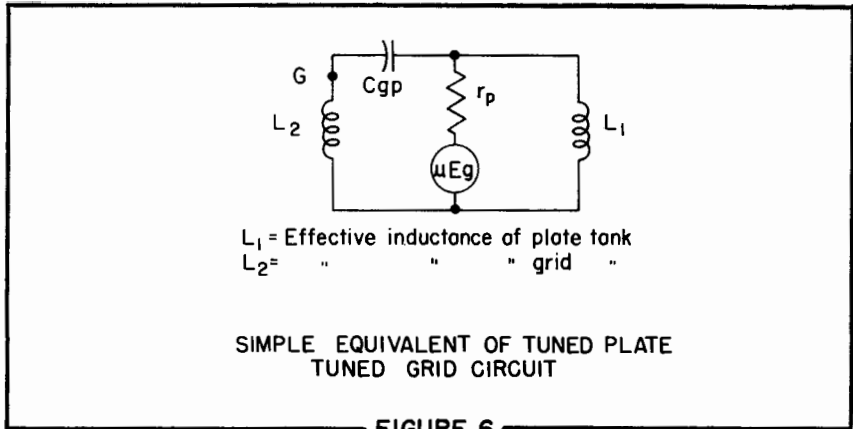

FIGURE 6

However, when the plate load impedance becomes inductive, and  $K_1$  becomes negative, the input resistance becomes negative. If the negative resistance exceeds grid losses, oscillation can take place. Thus a simple amplifier can become an oscillator if the plate load is inductive and the grid-plate capacitance is sufficient. As can be seen from Eq. 10, the frequency, grid-plate capacitance, and phase shift of gain are all interrelated in determining whether the input resistance is to be negative and oscillations will take place.

As in our previous discussions of inductive feedback oscillators, the effect of grid current is neglected and the tube is assumed to be a linear device, both permissible for most practical oscillators. It is also assumed that grid-plate capacitance has negligible effect on the gain.

About the only common type of oscillator depending primarily upon grid-plate capacitance for oscillation

is the tuned-plate-tuned-grid type illustrated in Fig. 5, with its equivalent circuit. In essence, it is simply a tuned-circuit amplifier adjusted to oscillate. Sometimes an external capacitor is connected between plate and grid; its purpose would be either to increase feedback at low frequencies or to improve stability by reducing the effect of variations in the grid-plate capacitance.

From the equivalent circuit it will be noted that the feedback coupling is the result of the fact the grid circuit and the grid-plate capacitance are connected in series across the plate signal voltage.

As was explained above, this type of circuit will oscillate if the plate load is inductive. Since the plate load here is a parallel tuned circuit, the resonant frequency of this tuned circuit must be made *higher* than the expected frequency of oscillation. The net reactance of the parallel combination is then inductive as desired.

It can also be shown that the grid tuned circuit must be tuned to be inductive, but slightly less inductive than the plate circuit.

The basic effective setup can perhaps be more clearly visualized by substituting inductances of the effective values for the two resonant circuits respectively, as illustrated in Fig. 6. It can be seen that for steady-state oscillation conditions, the effective inductances of the two tuned circuits and the grid-plate capacitance must resonate at the oscillation frequency.

The tuned-plate-tuned-grid oscillator has the disadvantage of depending upon the grid-plate capacitance of the tube for a vital part of its operation. Its stability of frequency is thus affected by the thermal and other causes of variation of this factor. Besides, the fact that the grid-plate capacitance is fixed causes the degree of feedback to vary in an undesirable manner when an appreciable frequency range is to be covered. These difficulties, added to the inconvenience and expense of providing two tuned circuits, are undoubtedly the reasons that this circuit is not often encountered.

A slight variation of the tuned-plate-tuned-grid circuit is the "TNT" version, in which the principle is the same, but the grid circuit is adjusted to its proper effective inductance by the distributed capacitance of the grid coil, instead of the grid capacitor. Although this eliminates the need for one capacitor, this circuit still retains all the other disadvantages of the tuned-plate-tuned-grid circuit.

#### Tuned-Circuit Feedback

Other types of oscillators do not employ either inductive or capacitive feedback in the manner described above, but derive the feedback phase and amplitude relation from a tuned circuit. This tuned circuit is ordinarily the same one which determines the frequency of oscillation.

Probably the best-known example of this type is the Hartley, illustrated with its equivalent circuit in Fig. 7. The tuned circuit is divided into two parts by the cathode tap. Grid and plate signal voltages of opposite phase are then obtained from the two ends, respectively, of the resonant circuit.

By analysis of the equivalent circuit in the same manner as for the inductive-feedback circuit earlier in this article, the following relations are obtained:

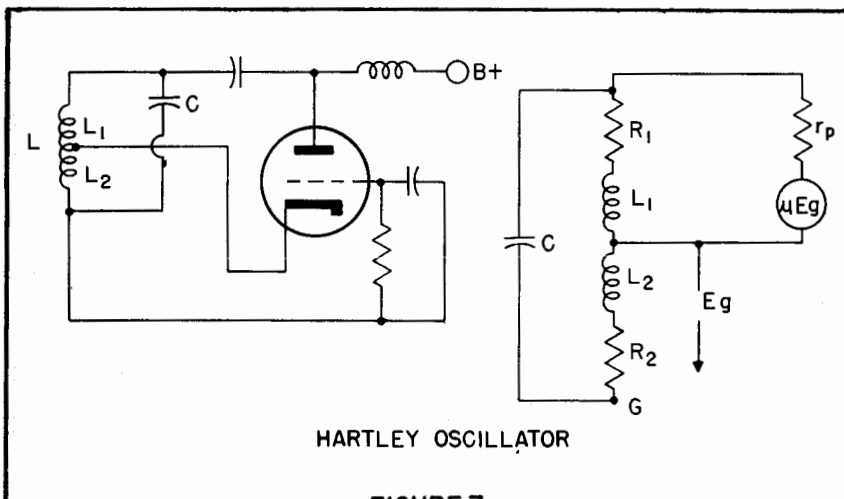

FIGURE 7

## HARTLEY OSCILLATOR

$$\omega \approx \sqrt{\frac{1 + \frac{R_1}{r_p}}{(L_1 + L_2 + 2N) C}} = \omega_0 \sqrt{1 + \frac{R_1}{r_p}} \quad [\text{Eq 12}]$$

$$g_m = \frac{C (R_1 + R_2) (L_1 + L_2 + 2M)}{(L_1 + M) (L_2 + M)} \quad [\text{Eq 13}]$$

$$\text{if } M = 0: \quad g_m = \frac{C (R_1 + R_2) (L_1 + L_2)}{L_1 + L_2} \quad [\text{Eq 14}]$$

$$\text{Eq. 15] or } g_m = \frac{C R L}{L_1 L_2} \quad \text{where } R = \text{total tuned circuit resistance (in } L)$$

$$M = \frac{L_1 + M}{L_2 + M} + \frac{C r_p R (L_1 + L_2 + 2M)}{(L_1 + M) (L_2 + M)} \quad (L_1 + L_2) \quad [\text{Eq 16}]$$

Note that the frequency relation Eq. 12 is the same as that for the tuned plate oscillator (Eq. 7) except that in this case it is the resistance of the plate section of the coil, instead of the total resistance of the coil, which influences frequency of operation. Thus it would be expected that for equivalent coils, the stability would be better for the Hartley.

From the expression for  $u$ , it can be seen that the greater the ratio of

It is interesting to note that it is not necessary to have either grid-plate capacitance or mutual inductance between the sections of the coil to support oscillation. The expressions are derived containing  $M$  because such  $M$  is usually present. However, if the two sections of the coil are entirely separated oscillation takes place. In fact, oscillation is even more vigorous without mutual inductance. Of course, the number of turns in each section of the

capacitance voltage divider instead of a tap on the coil. It is shown with equivalent circuit in Fig. 8. The expressions for this oscillator are as follows:

$$\omega = \omega_0 \sqrt{1 + \frac{R}{r_p} + \left(\frac{C_2}{C_1 + C_2}\right)} \quad [\text{Eq. 17}]$$

$$\mu = \frac{C_2}{C_1} + \frac{r_p R (C_1 + C_2)}{L} \quad [\text{Eq. 18}]$$

$$g_m = \frac{R (C_1 + C_2)}{L} \quad [\text{Eq. 19}]$$

Note that the tuned circuit must be adjusted for a resonant frequency slightly below the actual frequency of oscillation. The expressions for  $u$  and  $g_m$  are similar to those for the Hartley, except that they contain the divider capacitances instead of the sections of the coil. The values of both  $u$  and  $g_m$  necessary for oscillation are small. In the expression for frequency, the capacitance values play an important part. It is noteworthy that a relatively high value for  $C_2$  makes for less easy oscillation and poorer stability.

One of the important advantages of the Colpitts oscillator is the relatively large capacitances ( $C_1$  and  $C_2$ ) are shunted across the plate-to-cathode and grid-to-cathode interelectrode capacitances of the tube. This mini-

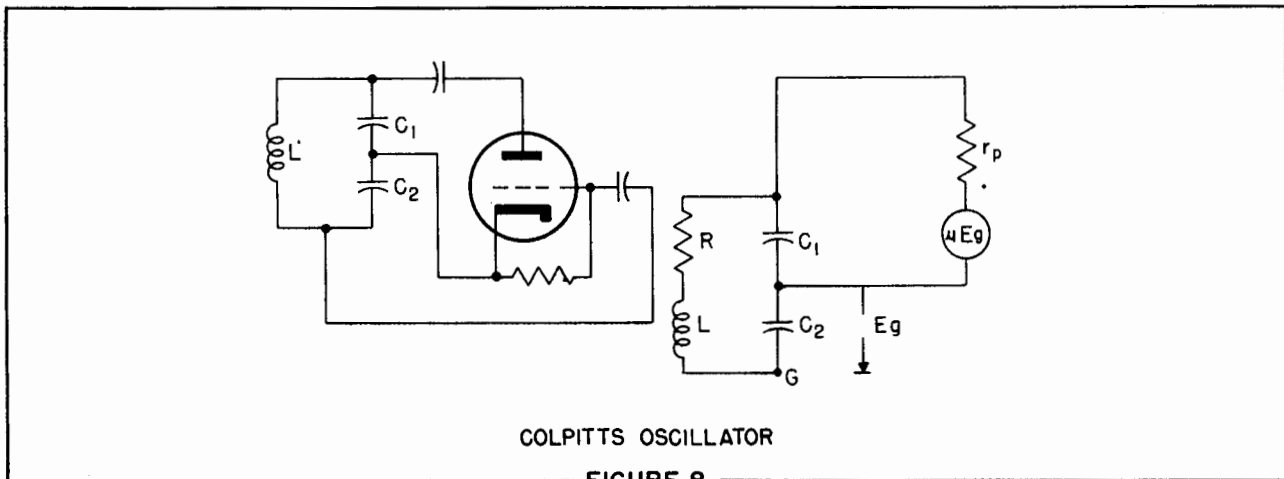

FIGURE 8

the grid-to-cathode section of the coil to the plate-to-cathode section, the easier it is for oscillation to take place. However, the plate section cannot be too small, since then there will not be sufficient transfer of energy from the plate to the coil.

coil must be somewhat greater, to make up for the loss of  $M$ , if the same frequency is to be maintained with the same tuning capacitor.

The Colpitts oscillator is a variation of the Hartley principle in which the tuned circuit is divided by a ca-

pacitance voltage divider instead of a tap on the coil. It is shown with equivalent circuit in Fig. 8. The expressions for this oscillator are as follows:

# Electronic Oscillators

## Part 2: Local Oscillators in A-M Receivers

A great majority of the local oscillators in AM receivers are part of converter-tube circuits. In short-wave communications receivers, separate-tube arrangements are frequently encountered, especially when the coverage extends to frequencies of 30 mc or higher.

### Arrangements Used.

The most popular oscillator circuit in AM receivers is the Hartley, although it does not usually appear in its basic form. Most frequently it is found as the grounded-plate version.

A typical pentagrid converter oscillator circuit is shown in Fig. 1 (A). The basic triode grounded-plate Hartley is shown at (B) for comparison. In the pentagrid converter, grids 2 and 4 take the place of the triode plate.

The circuit variation of Fig. 2 is particularly popular in small, low-priced AM receivers. An additional winding L1 is interwound with L2. L1 is called a "bifilar" winding. One end is left open. The capacitance between L1 and L2 takes the place of the capacitor C1 in Fig. 1.

Two examples of the use of inductive feedback in AM receivers are

shown in Fig. 3 and 4, respectively. The circuit of Fig. 3 employs the pentagrid converter version of the "tuned grid feedback" type. Figure 4 shows a cathode-coupled feedback arrangement. The latter can be pictured as the circuit of Fig. 3 with the plate feedback coil moved through the plate power supply and into the cathode circuit.

Inductive feedback circuits are not very frequently encountered in medium and higher-frequency receivers because of the expense of the additional coil winding and its connections, and because of the inconvenience of switching frequency bands. However, at low and very low frequencies, inductive feedback is often employed because of the difficulty in obtaining sufficient feedback other ways.

A typical dual triode oscillator-mixer circuit is shown in Fig. 5. This arrangement is popular in TV and communications receivers where low noise level and minimum oscillator/r-f interaction are required. Sometimes a small capacitor connected between grid or cathode of the oscillator and mixer grid is used for inject-

ing oscillator voltage to the mixer. In other cases, the cathodes of the mixer and oscillator are either common or coupled together.

### Requirements.

The following are important requirements in the design of oscillators in low-frequency AM receivers:

- (1) Ease of oscillation
- (2) Freedom from undesired resonances
- (3) Constant output amplitude
- (4) Frequency stability
- (5) Minimum of harmonic output
- (6) Tracking

### Ease of Oscillation

Conditions for oscillation must be well fulfilled, so there is no tendency toward delay or failure in starting or maintaining oscillation. The nature of these conditions was discussed in the first article of this series. Oscillation criteria show that from a general theoretical standpoint, the tuned grid feedback and Hartley are the easiest oscillators. The Colpitts circuit also oscillates easily, but is seldom used in receivers because of

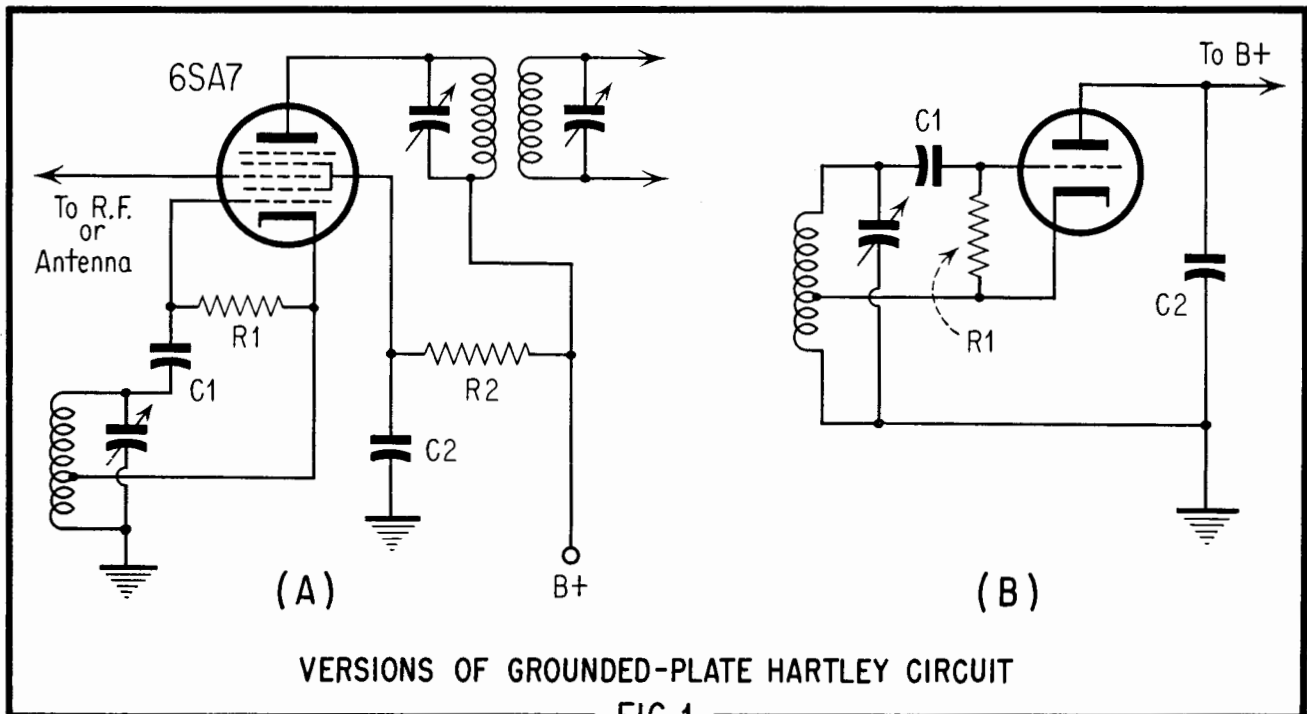

FIG. 1

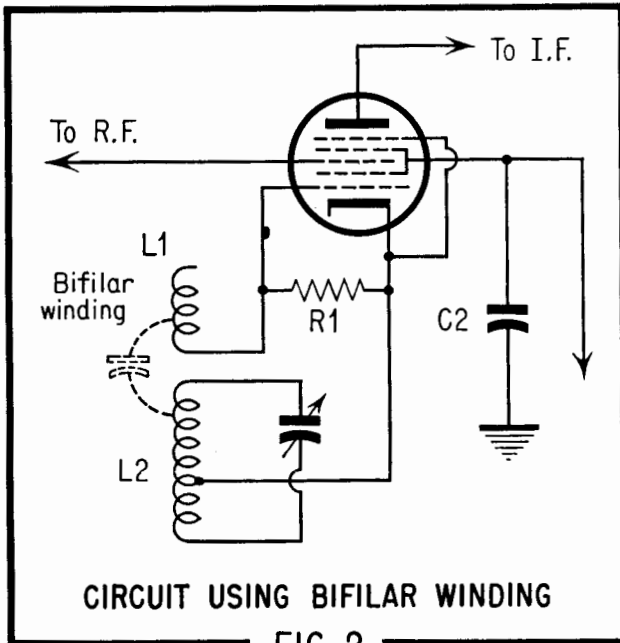

FIG. 2

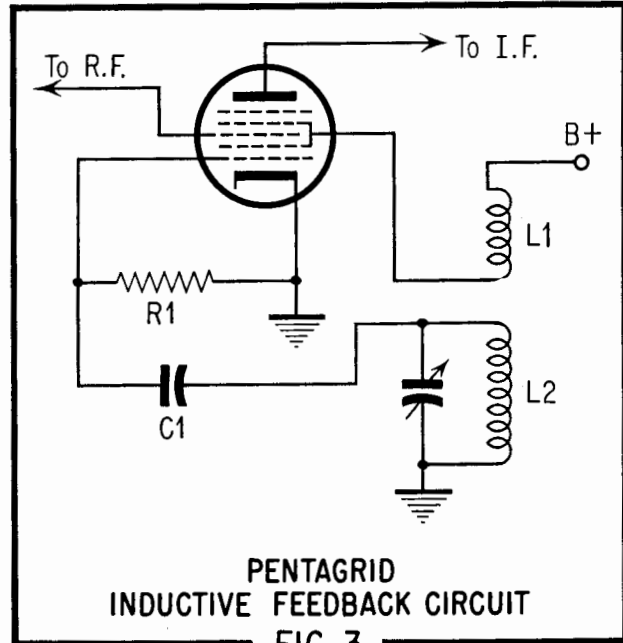

FIG. 3

the added components required (capacitors in the tank circuit).

If the basic design does not allow easy oscillation, then excessive plate and/or grid currents may be necessary, with resulting overheating and instability as well as excessive power requirement.

#### Undesired Resonances

Undesired resonances are most likely to occur in the inductive feedback type of circuits (tuned grid and tuned plate types). In these circuits the feedback or tickler coil may resonate with its distributed capacitance or with stray circuit capacitance. If the resonant frequency is within the tuning range, sufficient power may be absorbed to stop oscillation at and around that frequency. At least operation in the vicinity of the frequency of undesired resonance becomes unstable and undependable.

If the receiver is of the multi-range type, the coil of one range which is unused may self-resonate within the tuning range of the coil in use, with results similar to those mentioned above. The unwanted frequencies of resonance and their effects are often referred to as "dead spots" and "suck-outs".

Undesired resonances can, to an appreciable extent, be avoided by careful initial design. However, all possible resonances naturally cannot be anticipated, so a breadboard test for suck-outs is a sensible precaution. The best test is observation of the value of rectified grid current as the oscillator is tuned through its

range. The rectified current of the mixer injection grid is also a good indicator if separate oscillator and mixer tubes are used. Any tendency toward unwanted resonances will show up as sharp variations of this grid current as the resonant frequencies are approached. Such conditions can also be traced with a grid-dip oscillator, but it must be remembered that such an analysis is not complete unless the tuning capacitor of the tested oscillator is varied through its complete range. Sometimes the tuning capacitor is part of the undesired resonant circuit.

No general formula for eliminating unwanted resonances can be given; it's just a matter of changing the circuit constants so that these resonances are moved outside the tuning range, or better, but seldom possible, eliminated altogether. In multi-range receivers in which the coils of different ranges interfere with each other, the resonant frequency can be moved out of the range by adding a section of the switch which shorts each unused coil. On some ranges it may be better to leave the coil open when unused. In any event, a large percentage of troubles can be avoided by careful initial study of the inductances and capacitances involved, and the checking of each coil as to its self-resonance and its mutual inductance with other coils after installation in the circuit.

#### Constant Amplitude

The amplitude of oscillator injection voltage has an important effect

on the operation of a superheterodyne receiver. If the amplitude is excessive, and the mixer is driven beyond cutoff, sharp discontinuities in the conversion characteristic occur, and excessive oscillator harmonics result. These harmonics lead to many spurious responses, manifested by whistles and "birdies" in reception. On the other hand, if the injection voltage is too low, conversion transconductance falls off sharply, and receiver sensitivity is limited.

Thus it is important that the output amplitude of the oscillator remain constant over the tuning range. Unless compensated, the output of a capacitance-tuned oscillator increases as it is tuned from the low to the high frequency end of its tuning range. To compensate for this, some method of reducing relative output toward the high frequency end must be employed.

One convenient method employs the grid-cathode capacitance of the tube, with an added resistor to form a voltage divider, as shown in Fig. 6. Since the grid-cathode capacitance portion of the divider is a lower impedance at the higher frequencies, less voltage is applied to the grid from the grid circuit. Compensation for high frequency amplitude increase is thus afforded. Typical effect of compensation is illustrated in Fig. 7.

The circuit of Fig. 6 also compensates amplitude by its loading effect on the grid coil. The resistor and capacitor in series damp the coil with a shunt resistance which decreases



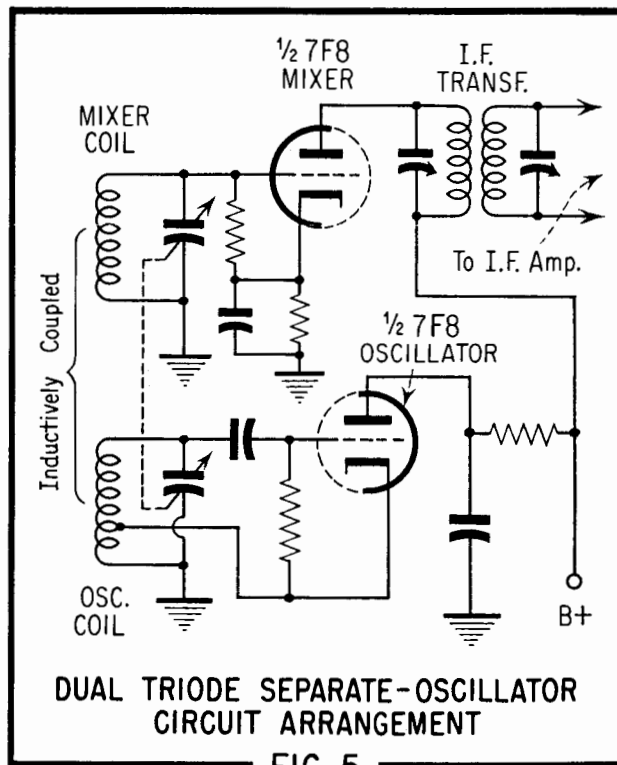
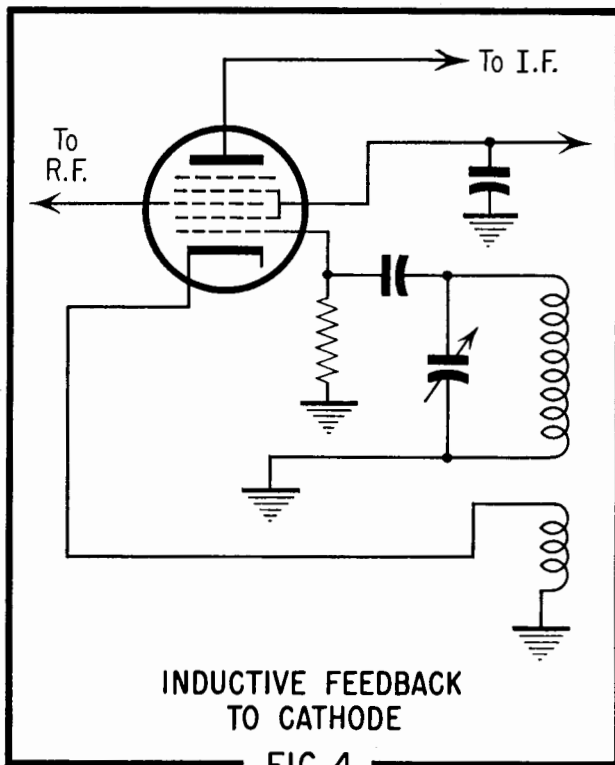

with frequency, thus compensating for the normal oscillator amplitude increase. The effective shunting resistance is the reciprocal of the real part of the admittance of the two components in series, which can be derived as

$$R_{\text{eff}} = \frac{1 + \omega^2 C_{gk}^2 R^2}{\omega^2 C_{gk}^2 R^2}$$

For example, if the tube has a grid-cathode capacitance of 10 uuf, a 1000-ohm resistor produces the following loading effect when connected in series with it:

at 550 kc	840,000 ohms
1000 kc	253,000 ohms
1600 kc	112,500 ohms
5 mc	10,100 ohms
10 mc	2,525 ohms

Obviously, the value chosen for the compensating element R depends upon the loaded effective Q of the circuit as well as the degree of original amplitude variation to be compensated.

Other methods for amplitude stabilization have been employed, but in most AM receivers cost limitations prevent use of any elaborate arrangements. Often the constancy of injection voltage is compromised somewhat so as to vary from the minimum allowable for sensitivity at the low frequency end to maximum which will sensibly limit spurious response at the high end.

#### Frequency-Stability

Since the frequency of the i-f signal, and thus proper reception, depends upon the frequency of the oscillator signal, frequency stability is very important. Its importance increases as receiver selectivity relative to received signal bandwidth increases.

For example, suppose an AM broadcast station transmitting audio modulation signals up to 12 kc is to be received. If the receiver has a pass band of just 24 kc, any drift in the local oscillator causes attenuation in the receiver of some of the high frequency modulation signal components. But suppose the same receiver is employed for a communications signal in which modulation frequencies are limited to a maximum of 3 kc, or a bandwidth of 6 kc. If this signal is originally tuned exactly in the center of the 12-kc receiver pass band, the oscillator can drift 3 kc either way without sideband clipping.

Oscillator drift is thus not as annoying if extra pass band is available at the receiver. However, in practical design, such extra response width is not ordinarily feasible (1) because of resulting increased noise and (2) because of adjacent channel interference effects.

Accordingly, appreciable attention must always be given to frequency stability. There are many factors

involved in stability and probably more work has been done with it than with any other feature of oscillator operation. Since frequency stability is discussed in detail in a later article covering transmitter oscillators, we shall not attempt full analysis at this point.

Frequency instability may arise from one or more of the following causes:

- (1) Variation in tuned circuit resonant frequency due to changes in L or C resulting from changes of temperature or humidity.
- (2) Changes in interelectrode capacitance values in the tube.
- (3) Fluctuation of operating voltages.
- (4) Changes in the load offered by the mixer.

One instability effect important in connection with oscillators in AM receivers is known as "pulling". Efforts to align the r-f tuned circuits to a received (or signal generator) signal result in a shift of oscillator frequency, detuning the receiver from the desired signal. This makes it difficult to obtain optimum alignment. The interaction is due to (1) space-charge coupling in the converter tube and (2) any direct coupling present between the oscillator and signal-grid coils or circuits.

If "pulling" cannot be completely eliminated in design, its effect can be

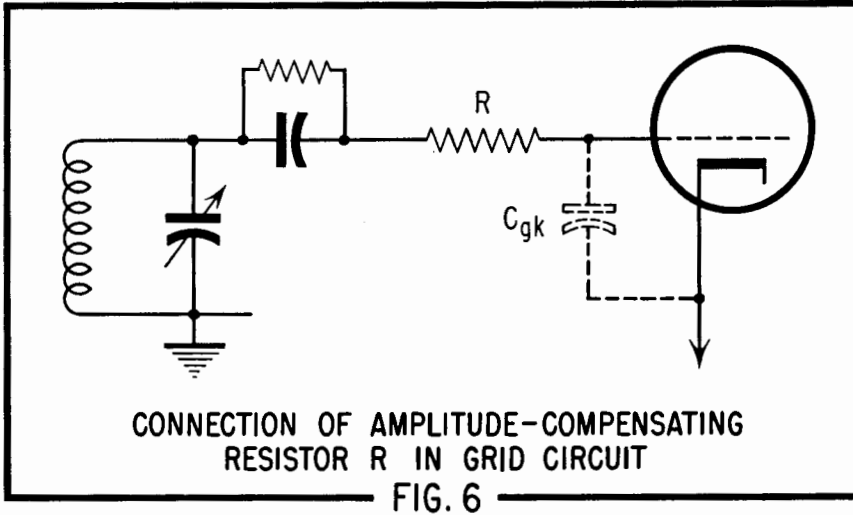

minimized by the "rocking" method of alignment. Better still, if a noise source is available, alignment by noise output will be free of pulling effects.

*Harmonics*

Harmonic output from the local oscillator is undesirable because it can lead to a number of different interference effects. Chief among these is the beating of an oscillator harmonic against a higher frequency station from which the harmonic is separated by the intermediate frequency. Harmonics also adversely affect stability of the fundamental.

A certain amount of harmonic output is inevitable for all r-f oscillators since non-linearity is essential to their operation. However, harmonics can be kept very low by careful attention to the following factors:

(1) Use of a low L/C ratio. The selectivity of the tuned circuit is then much greater because of the high Q of the tuned circuit. Unfortunately, in capacitance tuned oscillators, a low L/C ratio at the high frequency end of the tuning range is not consistent with full tuning range possible from a given tuning capacitor. Ordinary tuning capacitors, when connected into an oscillator circuit, provide a maximum tuning ratio of about 3 to 1. This ratio is attained only at the expense of a relatively high L/C ratio at the high frequency end of the tuning range. This problem can be overcome by inductance tuning, but such tuning is not practical or desirable in many receiver applications. Thus if harmonic output is to be minimized in wide-range tuning, other harmonic-reduction measures must be considered.

(2) Increased coil Q. Higher effective Q during operation can of

course be obtained by increasing coil Q as much as possible. Use of Litz wire within its favorable frequency range, use of bank and other special windings, and optimum dimensional relations are well known methods. In the appropriate frequency ranges, addition of a powdered iron core can provide an appreciable increase in Q.

(3) Limited power and drive. In most AM receivers, injection power requirements of the mixer are low enough to allow good operation with relatively low oscillator power output. Since harmonic content is greatly increased by use of large bias and drive voltage, it is desirable that

feedback be reduced to a minimum necessary for easy oscillation. For lowest harmonic content with appreciable output, most oscillators should approach class B operation. The design procedure would be as follows:

- (a) With no limitation on feedback path, adjust operating conditions, including feedback ratio, for maximum grid current. This would include adjustment of the tap on Hartley coil, capacitors in Colpitts divider etc. The objective of this step is to obtain optimum feedback phase relation.
- (b) Reduce applied plate and/or screen voltage to minimum values necessary for easy oscillation, also
- (c) simultaneously decouple the resonant circuit to minimize grid current for desired output. Greatest reduction of feedback amplitude with maintenance of optimum feedback phase should be the objective.

If the frequency range of the oscillator is such that a suitable sensitive radio receiver covering the fundamental and several harmonic frequencies is available, the method of Fig. 8 can be used for testing harmonic output. The signal generator should be of the laboratory type, with low leakage and dependable attenuator and output voltage readings. The coupling to the tested oscillator should be light and through a shielded link with as little capacitive coupling as possible. The receiver must be well shielded, and should have a signal meter. If it

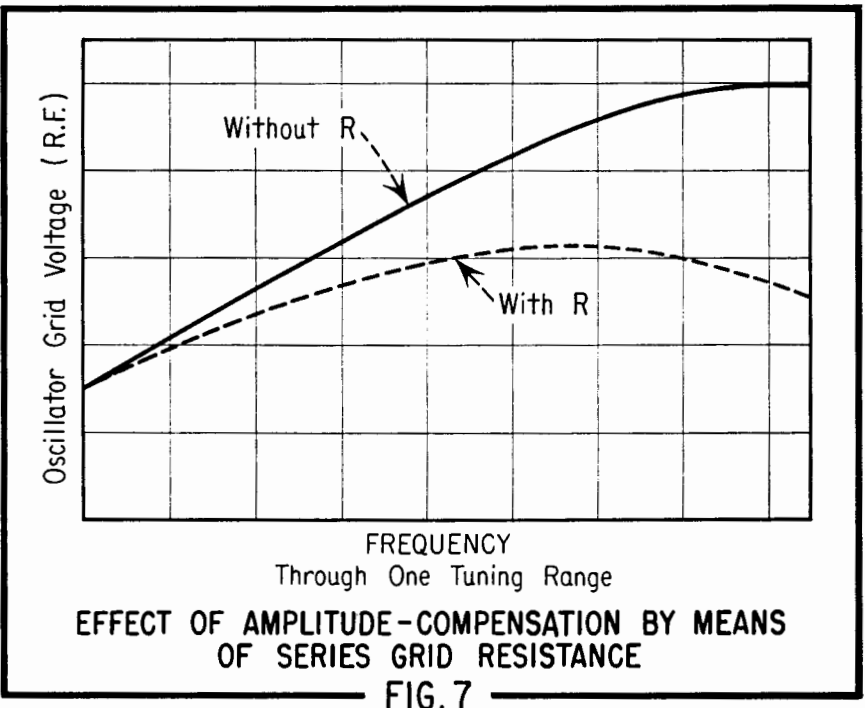

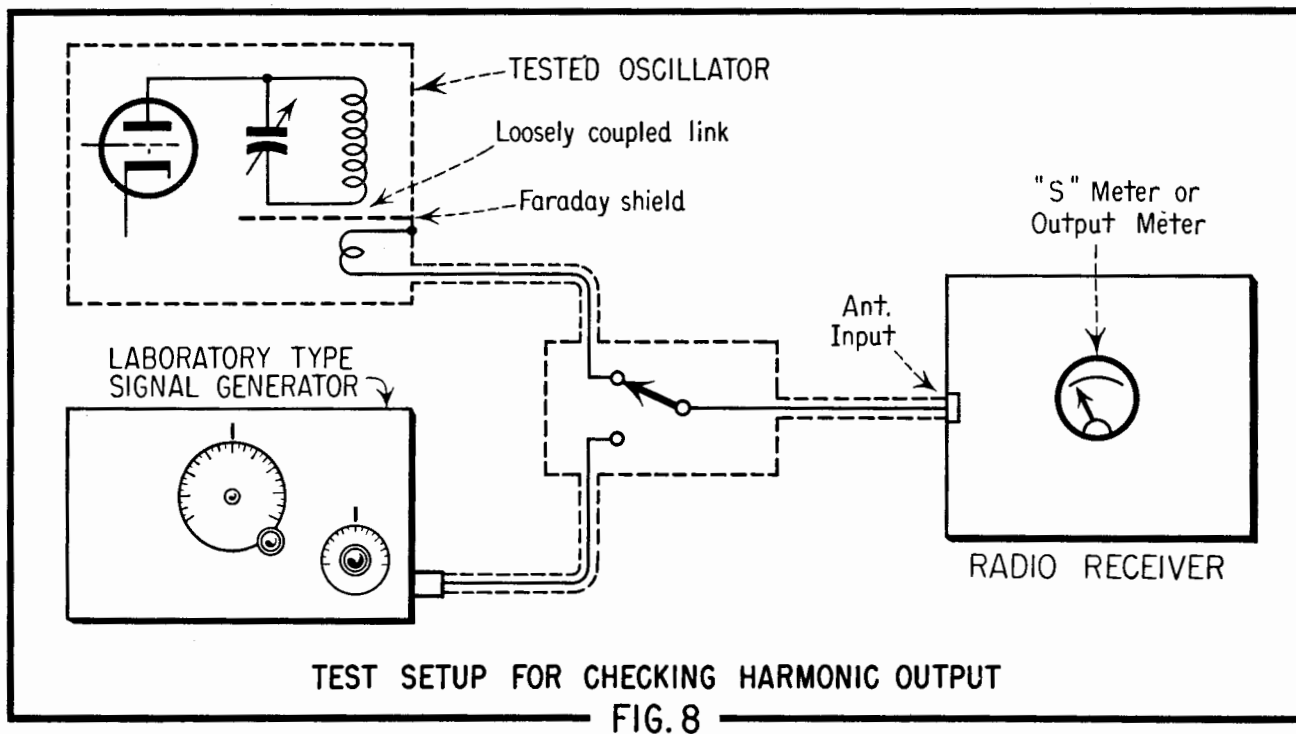

TEST SETUP FOR CHECKING HARMONIC OUTPUT  
FIG. 8

does not have a signal meter, VTVM measurement of AVC or detector d-c voltage output can be used. The coaxial lead should be terminated at the receiver with a composition resistor matching the characteristic impedance of the cable. The switch should be completely shielded in a box, to which connections are made through coaxial connectors.

The receiver is first tuned to the fundamental frequency of the oscillator, which should be the highest frequency of its range (for worst

harmonics). The signal generator is shut off. The receiver controls and the coupling to the oscillator are adjusted for convenient reference indication on the indicating meter.

Now switch S is thrown to the signal generator. The latter is turned on and the oscillator turned off. The signal generator attenuator is now adjusted for the same receiver output and its output voltage indication noted.

Next, without touching the coupling to the oscillator, repeat the

whole process, with the receiver tuned to the second harmonic of the oscillator frequency. The ratio of the signal generator voltages is the ratio of harmonic to fundamental. The same process should be repeated through at least the third, and preferably the fifth harmonic.

The final important requirement for the oscillator in the low frequency AM receiver is tracking. Since tracking is so important, it is discussed by itself in Part 3.

## Electronic Oscillators

### Part 3 - Tracking

ONE of the most important problems connected with local oscillators in gang-tuned radio receivers is *tracking*. Lower-priced AM broadcast receivers dispense with variable oscillator padders because tolerances of tracking and dial accuracy are relatively large. On the other hand, the better AM broadcast receivers, all-wave receivers, and especially communications receivers, are designed rather carefully for good tracking. Even in a receiver in which the oscillator padder is not variable, the fixed padder capacitor value should be carefully calculated.

The local oscillator frequency must, of course, tune so as to be always separated from the resonant frequency of the r-f tuned circuits by an amount equal to the intermediate frequency. This means that the oscillator tuning range in kilocycles or megacycles must be exactly equal to the tuning range of the r-f tuned circuit.

Suppose the r-f circuit and the oscillator circuit are both tuned by identical sections of a gang capacitor, and the oscillator coil inductance made smaller accordingly. The oscillator frequency cannot be kept

equally spaced from the resonant frequency of the r-f section without special tracking measures. Instead, the oscillator frequency varies as indicated by curve b of Fig. 1 where curve a is that of the r-f tuned circuit. Note that the actual heterodyne signal frequency changes from a relatively small difference frequency at the low end of the range to a relatively high difference frequency at the high end. It is the purpose of tracking circuits to make the oscillator frequency variation such that the r-f to oscillator frequency difference approaches a constant value

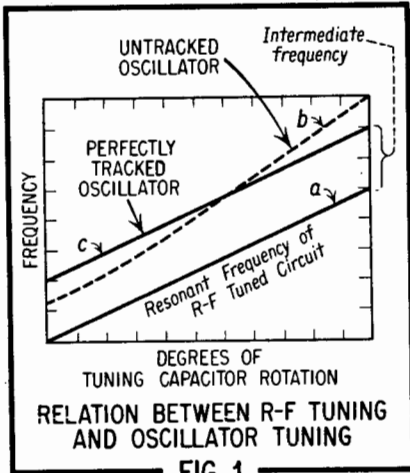
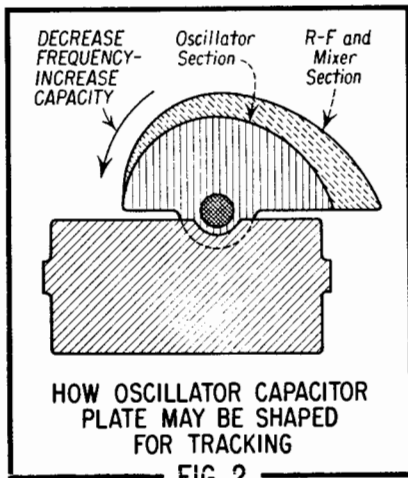

FIG. 1

equal to the intermediate frequency, as illustrated by curve c.

One simple way of providing tracking is by use of a smaller gang capacitor section for the oscillator, and "shaping" the rotor plates of the section. This shaping changes the capacitance vs rotation relation of the oscillator section of the capacitor so that it compensates for the deviation of curve b from the desired curve c. A typical shaped plate appearance is illustrated by Fig. 2. This method of tracking is widely used in low-priced AM broadcast receivers. It has two limitations: (1) it cannot be used in receivers providing more than one frequency band, because the plate shaping is good for only one range and (2) it provides no alignment adjustment for future correction for changes in the circuit constants due to temperature, humidity, dust, aging, etc.

Because of these limitations, the best available tracking method is considered to be that in which two adjustable capacitors are added to the oscillator circuit, as illustrated



HOW OSCILLATOR CAPACITOR PLATE MAY BE SHAPED FOR TRACKING

FIG. 2

in Fig. 3. One is connected across the variable tuning capacitor ( $C_T$ ) and is called a "shunt trimmer" or sometimes just "trimmer." The other is connected in series with one of the leads between the variable tuning capacitor and the oscillator coil ( $C_P$ ) and is called a "series padder" or just "padder."

At the high frequency end of the tuning range, the tuning capacitor  $C$  is at its minimum value, and the shunt trimmer has a relatively appreciable capacitance. Accordingly the shunt trimmer has a marked effect on the oscillator tuning curve at and near the high frequency end of the range, but negligible effect toward the low frequency end, where the tuning capacitor value becomes very large in comparison.

On the other hand, the series padder has an important effect at and near the low frequency end of the tuning range and negligible effect toward the high frequency end. This follows from the basic fact that when two capacitors are connected in series, variation of one capacitor has its greatest effect on the combined series capacitance when the other capacitor is at its maximum value.

Thus, when the oscillator tuning inductance is properly chosen, the shunt trimmer corrects the high frequency portion of the tuning curve, and the series padder corrects the low portion. If close tracking is required, both of these adjustments are necessary to overcome production tolerances in inductance, distributed capacitance and stray capacitance.

#### Method of Calculating Tracking Component Values

In order to ensure good tracking, the designer must compute the proper values of  $L$ ,  $C_T$  and  $C_P$  to make the oscillator tuning curve approach perfect relation to the r-f tuning curve. To do this, expressions can be set up for the resonant frequency of the combination of the three components in the tuned circuit plus the tuning capacitor section for each point at which oscillator tracking error is to be zero. Absolutely zero tracking error is of course not possible over the entire tuning range. However, the maximum error anywhere can be kept small by calculating circuit constants to give zero error at one or more frequencies. If these frequencies have been properly chosen, the remainder of the tuning curve will be very close to that desired.

The quality of a tracking circuit can be expressed by plotting the oscillator frequency error against frequencies in the r-f tuning range of

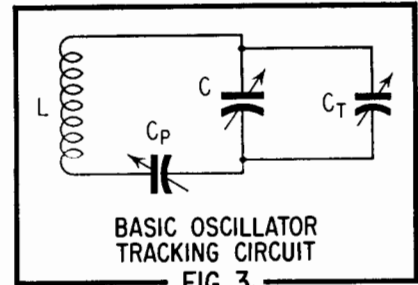

BASIC OSCILLATOR TRACKING CIRCUIT

FIG. 3

the receiver, as shown in Fig. 4. Positive errors (oscillator frequency too high) are plotted above the line, negative errors (oscillator frequency too low) below the line. The graph of Fig. 4 shows approximately the error variation resulting from the untracked curve of Fig. 1, curve b.

It can be shown that, as  $L$ ,  $C_T$  and  $C_P$  approach their proper values, the error curve takes the approximate form shown in Fig. 5. Because of the three variables, the curve equation is a cubic, and crosses the zero axis in three places. These three places are the frequencies of zero error. The proper locations of these frequencies can be determined by making certain assumptions. First, it is assumed that tracking is nearest perfect when the maximum error is the same at all four maximum points; in other words when the curve is symmetrical. By substituting boundary conditions in the general cubic equation, one derives the fact that the zero-error frequencies should be .

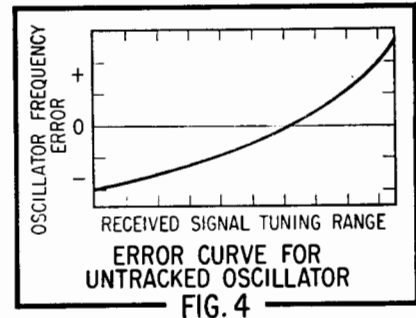

FIG. 4

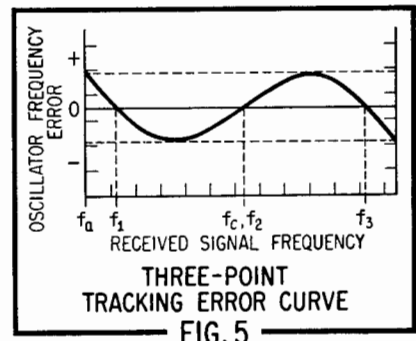

FIG. 5

$$f_1 = f_c - (f_c - f_a)$$

$$f_2 = f_c$$

$$f_3 = f_c + (f_c - f_a)$$

where

$f_1, f_2$  and  $f_3$  are the zero-error tracking frequencies

$f_c$  is the center frequency of the r-f tuning range

$f_a$  is the frequency at the low edge of the r-f tuning range

For the standard U. S. AM broadcast band of 550-1600 kc, these frequencies come out to be  $f_1$  — 620.35 kc,  $f_2$  — 1075 kc, and  $f_3$  — 1529.65 kc. Of course, individual manufacturers may have other considerations which have led to the use of different tracking frequencies; 600 kc and 1400 kc are widely used for the low and high points. These points ( $f_1$  and  $f_2$ ) are the ones at which the padder and trimmer capacitors, respectively, are adjusted. The center point should then fall automatically into place, providing the inductance is correct.

In the derivation of design expressions for the values of the shunt and series padder and the oscillator coil inductance, a general expression for the resonant frequency of the oscillator tank including the padder and trimmer plus tuning capacitor is set up. This general expression is then modified to form three expressions, one for each tracking frequency. These are in terms of the r-f tuning capacitor value (usually the same as the oscillator capacitor) and r-f tuning inductance. Solution of these three expressions simultaneously results in equations for the trimmer, padder and inductance. These mathematical operations and the resulting expressions for trimmer and padder

capacitance and inductance are quite cumbersome, so will not be repeated here. However, several approaches will be found in the literature.

#### Practical Modifying Factors

The previously-described treatment is one of several similar approaches to the problem. As mentioned above, other positions may be assumed for the end tracking frequencies, so they are within the tuning range instead of at its edges. Thus, it is common practice to use 600 kc and 1400 kc as low and high frequency alignment points, respectively, for the 550-1600 kc AM broadcast band. The design may also call for the center "zero-error" point to fall at the geometric mean (895 kc for the above range) instead of at the arithmetic mean frequency. Of course, this center tracking frequency is important only in initial design,

If the latter is correct the zero point automatically falls into place in subsequent alignment.

In practice, there must always be a certain amount of "cut-and-dry" adjustment of design values, after the latter have been theoretically determined. This is necessary because of modifying factors such as mutual inductance.

One of the assumptions of most analyses of tracking is that both the signal and oscillator tuned circuits are isolated and that the tuned coil and connected capacitance are the sole factors determining resonant frequency. Without this assumption, the mathematical expressions would become overly cumbersome.

Obviously signal and oscillator coils would be of no use if not coupled to anything. The practical approach is to minimize the reactive

component due to coupling, so the calculated tracking values still have practical meaning.

In the signal circuits, this would seem to favor the use of inductive coupling over capacitive coupling. It would also encourage the use of an electrostatic shield between primary and secondary windings of each tuned r-f transformer. By the same token, the oscillator would preferably be inductively coupled to the mixer, when separate tubes are employed, and such coupling would be as loose as possible. In pentagrid converters, a certain amount of space-charge capacitance coupling is of course inevitable.

When the oscillator is of the inductive feedback type, serious modification of the tracking design can result if the tickler coil has too much inductance. Tight coupling with low inductance is best, so that the self-resonant frequency of the tickler coil is well above the tuning range limits. If the coupled reactance is too large, it also limits the tuning range, an important factor when the latter is required to be relatively large.

#### Use of Slug-tuned Coils

In the idealized three-point tracking arrangement of Fig. 5, it is assumed that, although the series and shunt capacitance is adjustable during alignment, the inductance is fixed. This is true in a majority of cases.

Thus, in practical design, the engineer must anticipate what tolerance in fixed inductance value can be allowed consistent with permissible maximum tracking error. Figure 6 shows the effect on three-point tracking of changes in inductance,

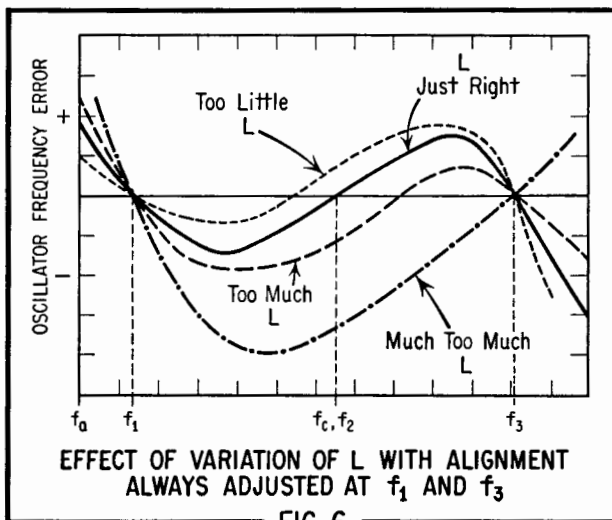

FIG. 6

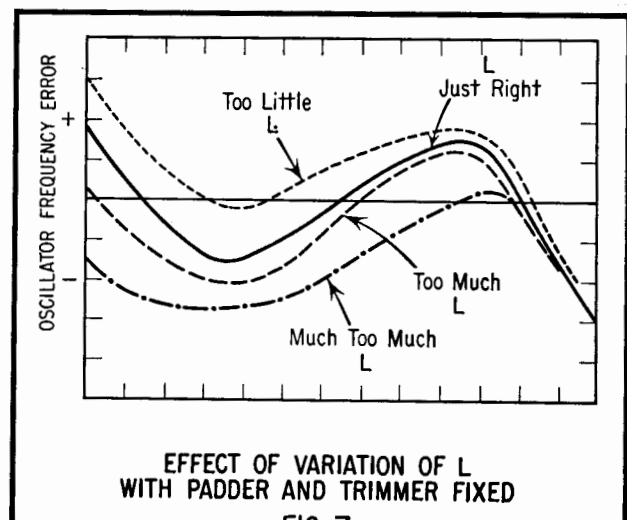

FIG. 7

assuming that, each time the inductance is changed, the trimmer and padder capacitors are readjusted to the predetermined edge or tracking frequencies. Note that as the inductance gets far away from its proper value, there becomes only one point of maximum tracking error, instead of two in the ideal case. The new maximum-error point is also shifted in frequency from its proper value.

In some receivers, notably those of the communications type, the oscillator coil is "slug-tuned" so its inductance can be varied for alignment

purposes. Normally, this adjustment substitutes for the series padder adjustment, so the latter can be made fixed. However, since there is only one pair of values for inductance and series capacitance which will satisfy the three-point design, the tolerance of the fixed padder capacitor is now the factor governing the maximum tracking error. The variation of tracking by adjustment of L when the padder capacitance is fixed is shown in Fig. 7. It can be seen that for perfect coincidence with the ideal tracking curve (Fig. 5) both L and series C, as well as shunt capaci-

tance, must be adjustable. This is seldom done in receivers, except in those in which both amplitude and phase of tracking must meet unusually rigid specifications (such as, for example, receivers used with goniometers.)

In many selective communications receivers, the *signal* circuits also have series padders or are slug tuned. This is necessary to overcome manufacturing tolerances in both oscillator and signal circuit components, and provides a high degree of tracking accuracy.

## Electronic Oscillators

### Part 4: VHF and UHF Oscillator Circuits

The last decade has seen a vast development of the frequencies above 30 mc, particularly the VHF (30-300 mc) and UHF (300-3,000 mc) ranges. The most important influences in this development have been radar, aircraft communications, and FM and TV broadcast services. In all these, oscillators play a vital role. This Part discusses the features of oscillators designed for operation in these ranges and using vacuum tubes of conventional design.

#### Special Problems at Higher Frequencies

Vacuum tubes of conventional (although sometimes somewhat modified) design are now being used in commercially-available equipment as oscillators operating as high as 1,000 mc and above. However, successful operation in the VHF and UHF regions of the spectrum requires that certain difficulties be overcome. These difficulties arise from vacuum tube factors, and circuit factors, which, although not noticeable at low frequencies, take on special significance in the higher frequency ranges. Figure 1 illustrates these factors, which are, as far as the tube itself is concerned, transit time, lead inductance, and interelectrode capacitance. These electrical tube factors are discussed first, followed by additional important circuit and physical factors.

Transit time is the time it takes an electron in the tube's electron stream to travel from cathode to plate. If this transit time is appreciable compared to the period of 1

cycle at the desired frequency of oscillation, it is extremely difficult to sustain oscillation. This is because, as the transit time approaches the period of 1 cycle, the phasing between plate and grid voltages is affected in such a way as to introduce the effect of *shunting resistance* (conductance) between grid and cathode. Since all or part of the tuned circuit is connected or coupled between grid and cathode, the oscillating circuit is adversely loaded by this resistance effect. An undue

amount of power may thus be dissipated, and in severe cases (higher frequencies and unsuitable tubes) sufficient energy cannot be fed back to sustain oscillation. Many tubes which have input impedances as high as 5 to 20 megohms at low frequencies (below 3 mc) have values as low as 20 to 200 ohms at 500 mc and higher.

Transit time is obviously a function of the spacing between the cathode and the plate of the tube; the greater the spacing, the longer it takes for the electrons to traverse the span. It is also a function of the relative grid-to-cathode spacing, since the effect on the *relation* between the grid and the plate is important. The  $G_m$  (transconductance) of the tube, which of course is influenced by these spacings, also affects transit-time. The conductance, which is the harmful effect, resulting from transit time, is directly proportional to  $G_m$  and inversely proportional to the *square* of the frequency. However, the  $G_m$  must be kept high to support oscillation and provide stability, so the transit time must be kept down by minimizing spacings and interelectrode capacitance. An increase in plate voltage reduces transit time by speeding up the electron stream, but increasing plate voltage over its rated value is likely to overload the tube, and so is not a satisfactory method.

The magnitude of the effect of transit time on input loading can be gauged from the following expression:

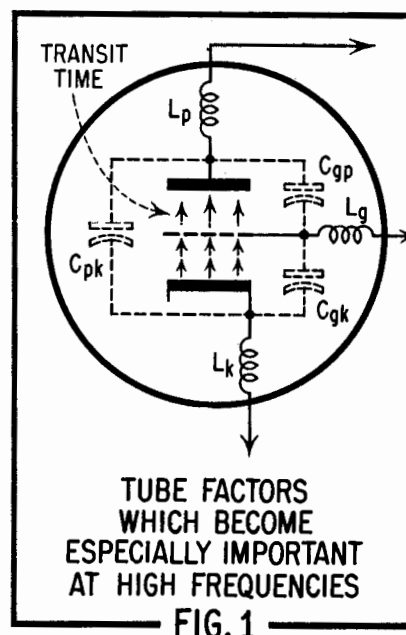

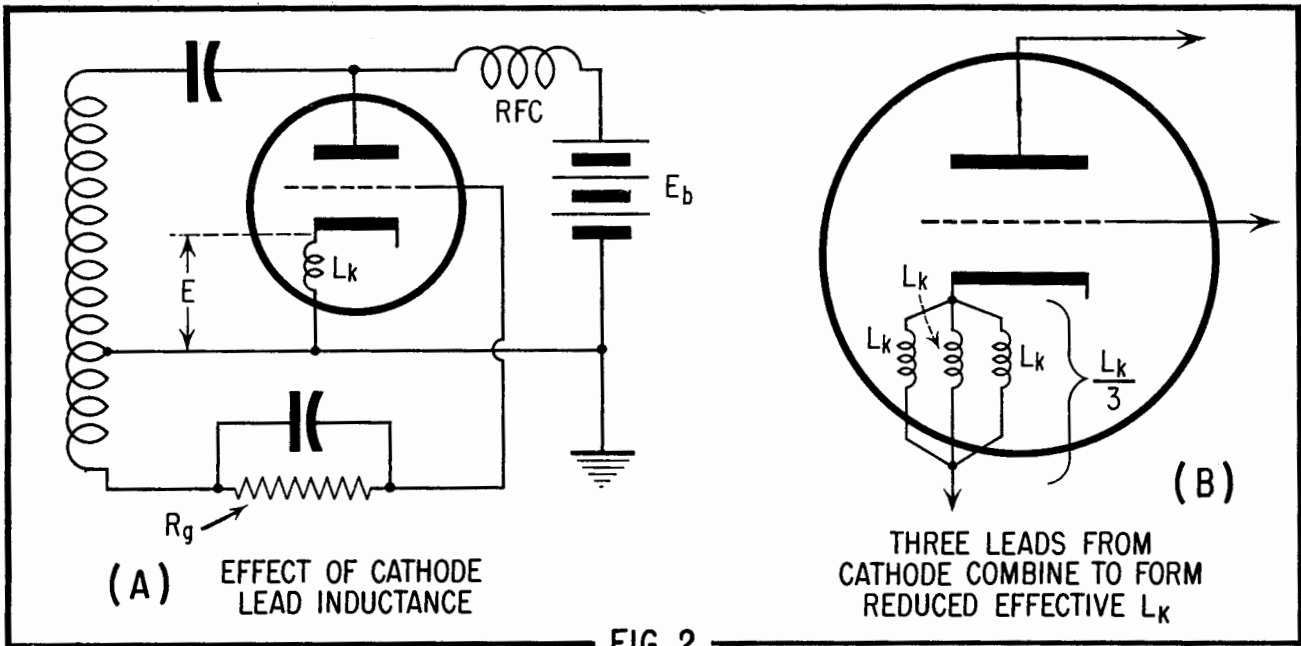

FIG. 2

$$G_g = KG_m f^2 T^2$$

where:

- $G_g$  = grid input conductance due to transit time.
- $G_m$  = tube transconductance.
- $f$  = frequency of oscillation.
- $T$  = transit time from cathode to grid.
- $K$  = constant depending on tube construction.

Although this expression is derived for a negative grid, it is just as useful qualitatively in the case of an oscillator.

Note that the input conductance increases (resistance decreases) with the square of the frequency. Thus the input resistance of a tube at 100 mc can be expected to be only one ten-thousandth of its value at 1 mc.

Lead inductance the self-inductance of the wire connecting each tube element to its corresponding pin, cap or connector. At high frequencies it represents an appreciable reactance between the tube elements and the external oscillator circuit.

In the conventional grounded-cathode oscillator circuits, cathode lead inductance is of particular importance. The reason for this is illustrated in Fig. 2(A). The cathode lead inductance  $L_k$  is in series with both the plate and the grid r-f return circuits. It therefore develops a feedback voltage  $E$  which is degenerative, the same as in the case of an unbypassed cathode resistor in an audio amplifier. At high enough frequencies, the degenerative effect seriously interferes with oscillation. The presence of cathode lead inductance ( $L_k$ ) causes the ef-

fective voltage between grid and cathode of the tube to have a different phase angle than that of the externally-applied voltage. The difference is due to the feedback voltage across  $L_k$  due to plate current. The result is a conductance component in input admittance which adds to the conductance due to the transit time.

It has been shown that input conductance due to  $L_k$  is

$$G_g = \omega^2 G_m L_k C_{gk}$$

where:

- $G_g$  = input conductance due to  $L_k$ .
- $\omega$  = angular velocity of oscillation ( $2\pi f$ )
- $G_m$  = tube transconductance.
- $L_k$  = cathode lead inductance.
- $C_{gk}$  = grid-cathode interelectrode capacitance.

Bad effects also result from inductances of other leads, as is discussed later.

To reduce the effect of lead inductance, many tubes designed for high frequency use are supplied with two or more leads and external connections from the same element. The two or more leads can then be connected together right at the socket. This connects the lead inductances in parallel, thus reducing the total lead inductance effect to the inductance of one lead divided by the number of leads so connected. This is illustrated for a cathode lead in Fig. 2(B).

Interelectrode capacitances have a shunting effect due to their relatively low reactance value at high frequencies. The charging current

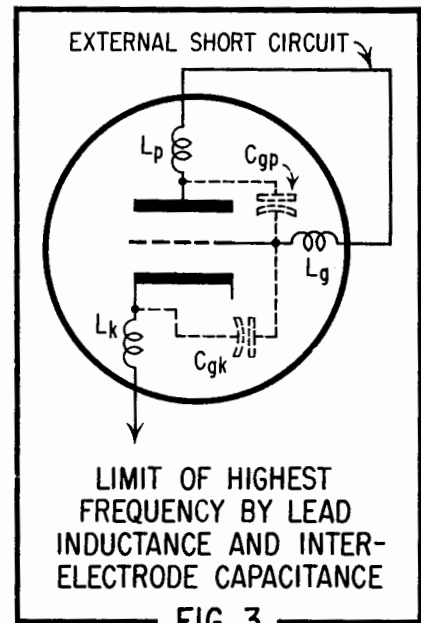
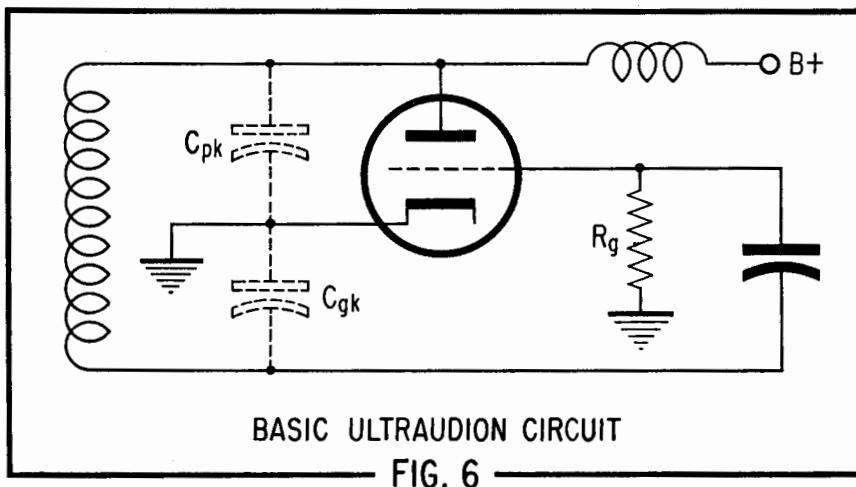
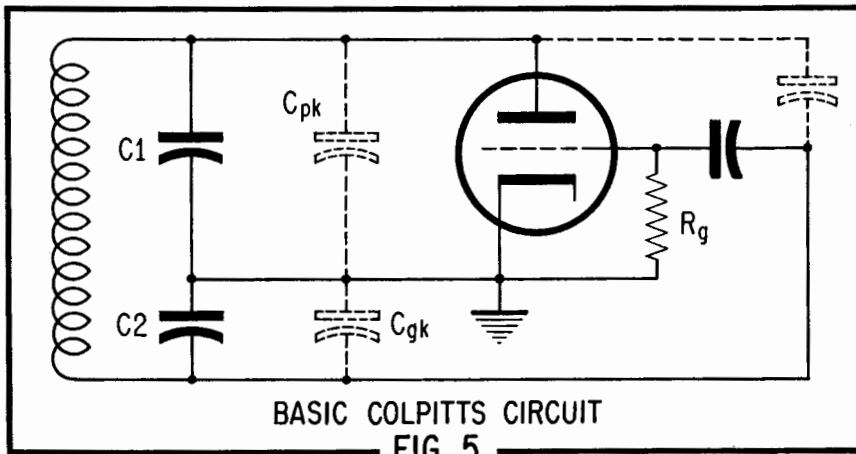
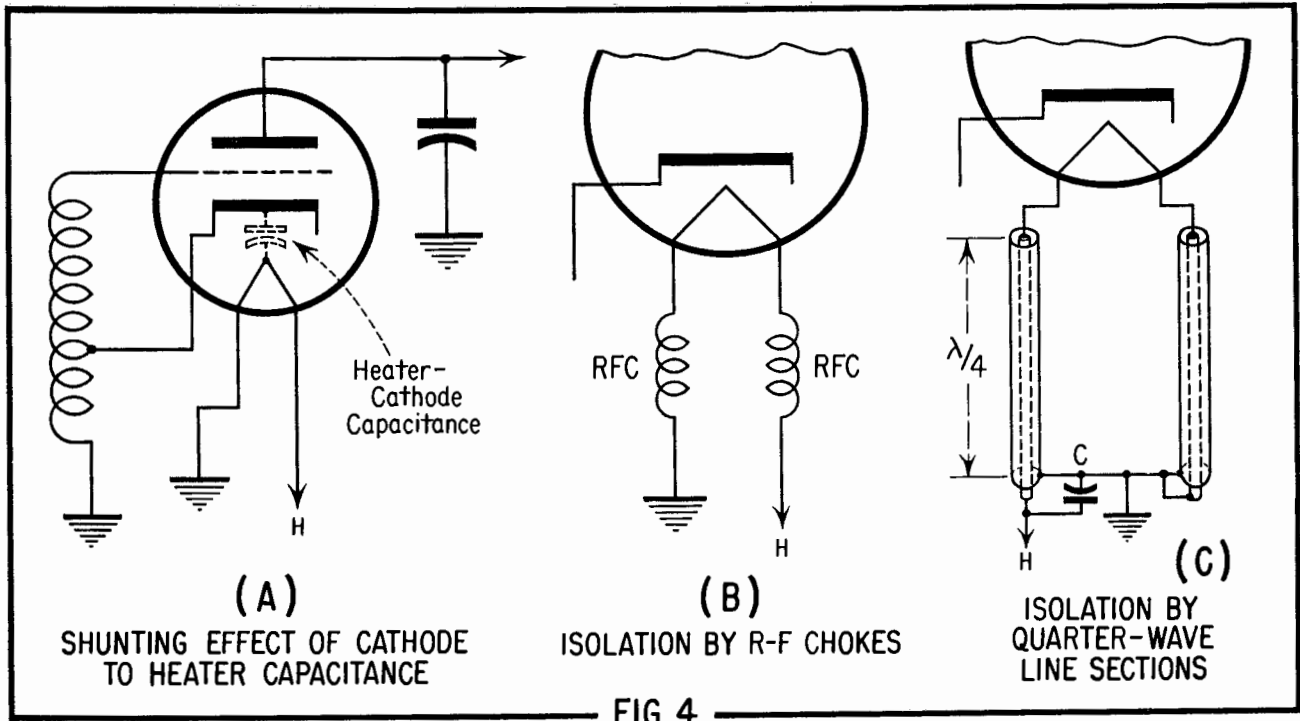

FIG. 3

through these capacitances results in power loss in the resistance of the circuit and adds to the power loss in the dielectric, which is the insulating material of the tube.

#### Limitation by Tube of Minimum Tuned Circuit Size

The oscillation frequency is determined not by the external tuned circuit constants alone, but by the external tuned circuit plus the lead inductance and interelectrode capacitances of the tube. The combined effective tuned circuit thus reaches an irreducible minimum size (and maximum resonant frequency) when



the external tank is replaced by a direct short circuit. The effective tuned circuit is then composed of the lead inductances and the interelectrode capacitance, as illustrated in Fig. 3. Since nothing further can be done to decrease inductance or capacitance, the tube has reached its upper frequency limit even though transit time might allow it to operate at a higher frequency.

Thus, if a tube is to oscillate at a very high frequency, its lead inductance and interelectrode capacitance must be small enough to allow resonance with some sort of external tuned circuit. Preferably, the plate, grid and cathode must be located so that a high frequency tuned circuit can be directly connected without intervening leads.

Triodes are by far the most popular tube type for high frequency oscillators, because of their low interelectrode capacitance. Types with the highest  $G_m$  are of course the most suitable. As has been previously explained, having several leads from each of the active elements is also helpful.

#### *Influence of Circuit Construction on High Frequency Operation*

Even when the vacuum tube is properly chosen, high frequency operation may be adversely affected by the character and construction of the circuit.

All kinds of circuit losses increase rapidly with frequency, and, if not



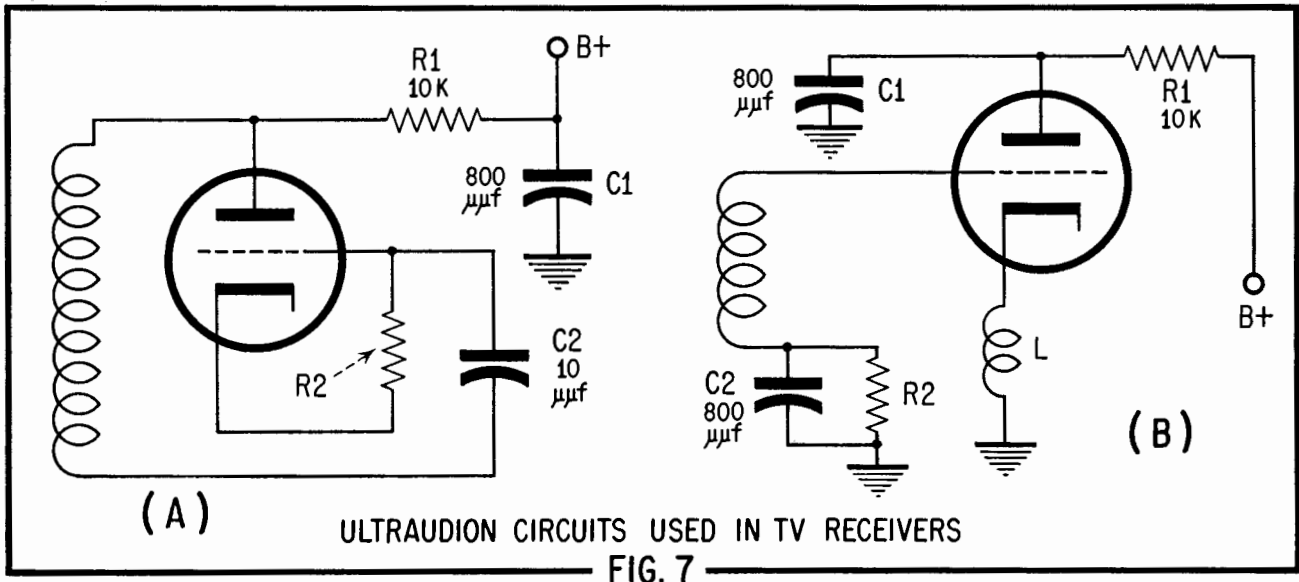

properly controlled, may keep feedback from being sufficient to support oscillation. Wiring must be direct and of heavy-gauge wire to combat skin effect, wherever r-f current flows. Any points of r-f voltage should be either suspended in air or mounted on low-loss material such as polystyrene or polyethylene. Although chassis grounding should be as direct as possible, it should all be done at one point in each circuit, to prevent bad effects of r-f currents in the chassis. Soldered connections must be the best possible; any tendency toward a "cold joint" or "rosin joint" can introduce extreme losses and may prevent oscillation.

*Operating the Heater at Cathode R-F Potential*

The construction of modern vacuum tubes is such that there is an appreciable capacitance between the heater and the cathode (2 to 10 uuf). Thus, in circuits in which the cathode is operated above ground, serious shunting of the cathode can

occur through this capacitance to the grounded heater, as shown in Fig. 4. This can be overcome by isolating the heater from ground as far as r-f is concerned, and operating it in the tube at the same r-f potential as the cathode. One way of doing this is shown at (B) in Fig. 4. An r-f choke is connected in each heater lead; the cathode r-f voltage can build up across the reactance of each choke, although the 60-cps alternating current for the heater is allowed to pass.

Another arrangement is shown in Fig. 4(C). Here the heater is isolated from r-f ground by means of a quarter-wave resonant transmission line section in each lead. Both line sections are short-circuited to r-f at the bottom (one directly, the other through capacitor C). This means that there is a high impedance at the other end between the inner conductor and the grounded outer conductor. The heater leads are fed through these inner conductors and are thus at a high impedance to ground, thus preventing shunting of the cathode.

*Types of Circuits Used*

Many of the same types of circuits used at low frequencies are also popular in the VHF and UHF ranges. Such circuits as the Hartley are frequently encountered, especially in the "grounded plate" form (see Part 2 of this series). High frequency versions may be a little difficult to recognize at first, as special tank circuits and other construction are often employed.

Of particular importance is the Colpitts circuit of Fig. 5, not only because it is sometimes used itself, but mainly because it is the basis of the very popular *ultraudion* circuit, which will be explained presently.

The Colpitts oscillator circuit is the same as the Hartley except that the cathode is tapped into the resonant circuit by means of a capacitance voltage divider C1-C2, instead of a tap on the coil. One advantage of this arrangement is that the two interelectrode capacitances  $C_{pk}$  and  $C_{gk}$  are not connected directly across parts of the coil, as they are in the Hartley. They are shunted by tuned circuit capacitors C1 and C2. The latter have large values, since they combine in series to provide the total external resonant circuit capacitance. The effect of interelectrode capacitance variation on the frequency of oscillation is thus minimized. There is one disadvantage in the Colpitts circuit when the oscillator is to be tuned over a range, as in receiver local oscillators. Either C1 and C2 must be tuned together, or another capacitor must be added across all or part of the coil to provide tuning adjustment. The relative values of

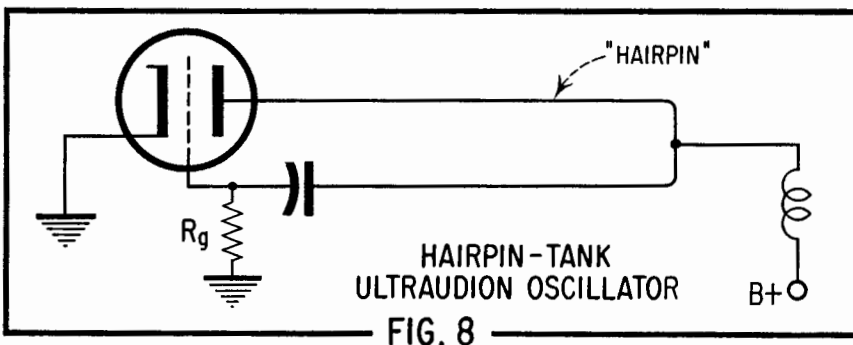

C1 and C2 determine the amount of feedback, just as adjustment of the tap did in the Hartley oscillator. Thus variation of either of these capacitors alone would vary feedback as well as frequency, an obviously unsatisfactory condition.

*The Ultraudion*

The ultraudion circuit is undoubtedly the most popular of any of the circuits used for the VHF and UHF ranges. It is widely used as the local oscillator in communications, FM broadcast and TV broadcast receivers, because of its simplicity. The circuit is actually simply a Colpitts type in which the plate-cathode and grid-cathode interelectrode capacitances form the voltage divider across the coil. No external capacitors are then needed, although of course some form of trimmer or adjusting capacitor must usually be added across the coil, so the frequency can be set or varied.

The principle of the ultraudion is illustrated in Fig. 6, which shows how the interelectrode capacitances form the Colpitts-type voltage divider.

As with other oscillator types, any desired point in the r-f circuit can be chosen as ground, to suit convenience in the particular application. Two examples of ultraudion local oscillator circuits used in TV receivers are shown in Fig. 7. In the type at (A), the cathode is grounded. The plate is shunt fed through R1, which keeps it at r-f potential above ground. Optimum efficiency and power output would call for an r-f choke instead of R1. However, in this case, sufficient receiver injection voltage, and better stability can be obtained with the lower-priced resistor, because a voltage dropping resistor is probably necessary anyway. In the circuit at (B), the plate is grounded to r-f, through C1. This means that both the grid and the cathode must op-

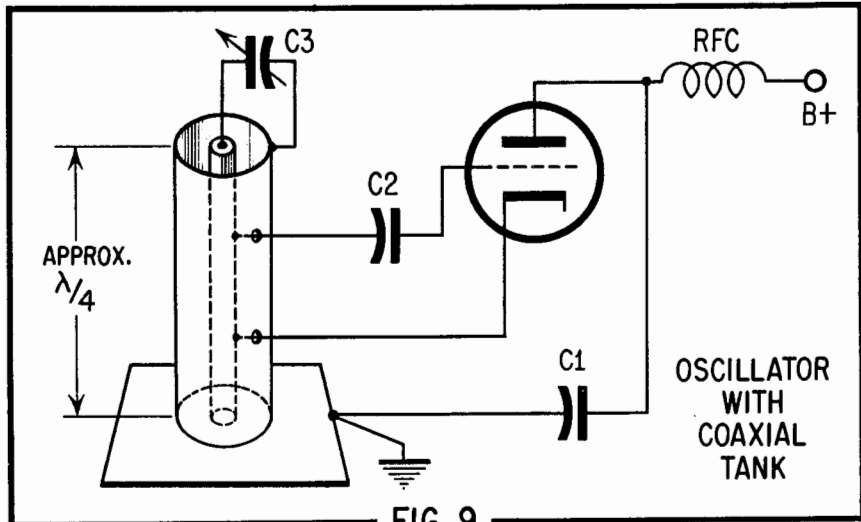

FIG. 9

erate at above-ground r-f potential. The cathode is kept above ground by means of the cathode choke L, which allows d-c cathode current to pass through from ground to the tube.

*Use of Transmission Lines as Tank Circuits*

Because of the relatively high circuit losses and the effects of transit time at high frequencies, the inherent stability of an oscillator lessens as the frequency is increased into the VHF and UHF regions. One way to compensate for this is to design the resonant (tank) circuit so it has a very high Q, and thus tends to stabilize the oscillator as a whole. This can be done by using a resonant section of a transmission line as the tank circuit, instead of the ordinary coil and capacitor. For example, a quarter-wavelength section of transmission line, short-circuited at one end, exhibits at the other end the characteristics of a very high Q parallel-resonant circuit. By slight adjustment of the length of the line section, it can be

made to combine with circuit and tube reactances plus added tuning capacitance if desired, to resonate at the required operating frequency. An open-ended line section a half-wavelength long can be used in the same way.

An example of the use of a line section for the tank circuit of an oscillator is shown in Fig. 8. Because of the appearance of the shorted line, which is usually fashioned from a single piece bent into shape, this arrangement is often referred to as the "hairpin" oscillator. Actually the circuit is an ultraudion, and the construction is about the simplest of any practical oscillator.

This application is not limited to open wire lines, but coaxial line sections also can be used. A Hartley circuit using a quarter-wave coaxial section is shown in Fig. 9. The line is shorted and grounded at the bottom, where the plate is also connected through C1. The circuit is thus a grounded-plate Hartley. The leads from the cathode and grid respectively are fed through the outer conductor of the line section and tapped onto the inner conductor. This simulates the connection of these leads to the tap and top respectively of a conventional coil. C3 is added for variation or adjustment of frequency. Sometimes frequency adjustment is provided by a shorting plug of metal between the inner and outer conductors, which is moved to change the electrical position of the bottom short circuit.

Push-pull oscillator circuits have the advantage at high frequencies that the combined effective interelectrode capacitances are lower than those of each tube alone. A typical push-pull tuned-plate-tuned-grid oscillator circuit using transmission line tanks is shown in Fig. 10.

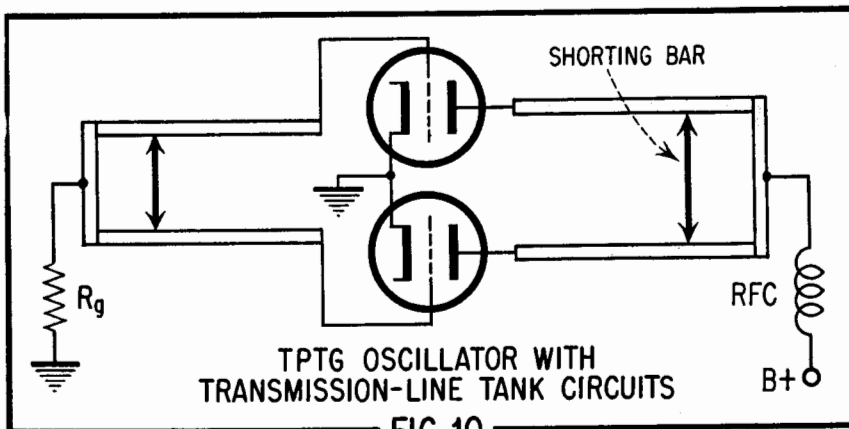

FIG. 10

# Regulated Power Supply Design

A source of well-regulated plate voltage is a prerequisite for the modern laboratory, service bench or amateur station. An ever increasing number of electronic devices, such as audio amplifiers, r.f. oscillators, amateur vfo's, oscilloscopes, synchoscopes, timing circuitry, and many others, depend for their proper functioning upon a power supply which is hum free and delivers a constant voltage regardless of load. Fortunately, the development of electronically regulated sources has advanced to the state where their design and construction is well within the scope of the average user. The theory, design and construction of a representative supply of this type will be outlined here. With a firm understanding of the design principles to be discussed, the reader should be able to adapt the practical supply presented here to other requirements which might exist.

Modern regulated supplies of the type to be described make available an output voltage which is continuously variable over a considerable range and which will not vary more than a fraction of one percent between no-load and full-load conditions. Normal line voltage fluctuations also have little effect on output voltage. In addition, the regulation may be made of such a high order that ripple voltages in the output are almost entirely cancelled, thus eliminating the need for the usual "brute force" filter. This saving in weight and space helps to compensate for the additional complexity of the electronic regulator.

## Theory of Operation

To achieve precise voltage regulation, an electronic voltage control element must be introduced in the conventional supply circuit. In most regulated supplies, this electronically variable element takes the form of a high current vacuum tube, usually called the "pass tube" or "regulator tube" in this application. This tube

is connected in series with the load resistance across the output of the supply, as in Fig. 1. Since the resistance of the triode varies as a function of its grid voltage, this combination acts as an electronically controlled voltage divider. A small change in the regulator tube grid voltage changes the effective ratio of the divider and thus varies the voltage appearing across the output load.

The ability to vary the output voltage of the supply by a minute grid voltage change suggests that automatic voltage regulation could be accomplished by feeding any attempted output voltage fluctuation back to this grid at such a polarity as to oppose that change. In other words, if the voltage across the load in Fig. 1 attempted to rise, the grid of the pass tube (V1) should be made more negative so that its internal resistance would increase and lower the load voltage. If the load voltage attempted to decrease, the converse action should occur.

This action is achieved by the circuit shown in simplified form in Fig. 2. Auxiliary circuitry consisting of a second vacuum tube, usually called the "control tube", and a constant voltage source such as a battery or "VR" tube is added to the circuit of Fig. 1. A sample of the output voltage is applied to the grid of the control tube by a tap on the output bleeder R1. The control tube determines the bias on the regulator tube (V1) since the load resistor (R2) for the control tube is also the bias resistor for the regulator tube. The control tube therefore performs two functions; it amplifies voltage fluctuations impressed upon its grid by the output circuit, and it reverses the phase of those fluctuations so that they may be applied to the grid of the pass tube in the right direction to effect regulation. The precision of the regulation attained increases with the gain of the control tube

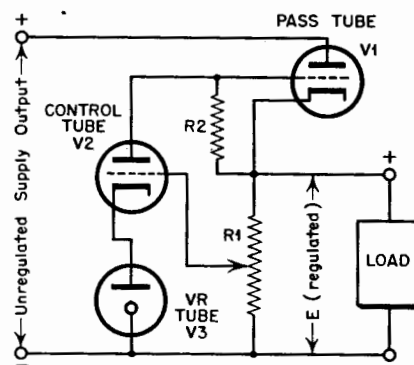

SIMPLIFIED ELECTRONIC REGULATOR  
FIG. 2

since, with greater gain, a small change in control tube grid voltage will cause a greater control tube current change and hence a greater change in pass tube bias. Thus, smaller attempted output voltage excursions will be corrected.

The battery or VR tube maintains the cathode of the control tube at a constant voltage above ground, and thus provides a standard reference voltage to which voltage fluctuations at the output divider (R1) are compared. The voltage at the grid of the control tube is the difference between the voltage at the output bleeder tap and the reference bias voltage provided by the VR tube. This difference voltage sets the "target" voltage to which the supply regulates. By changing the output bleeder tap with a potentiometer at R1, the regulated output voltage of the supply may be adjusted within certain limits.

Summarized briefly, the action of the electronic regulator of Fig. 2 is as follows: The position of the bleeder tap on R1 determines the output voltage level to which the supply will regulate. If the voltage across the bleeder attempts to rise above that level, the bias on the control tube (V2) becomes more positive, causing it to draw more current through its load resistor (R2). The increased current through R2 causes the grid of the regulator tube (V1) to be driven more negative, with the result that the resistance of the regulator tube increases sufficiently to prevent the original attempted excursion of output voltage and return it to the regulated level. If the output voltage attempts to decrease, the se-

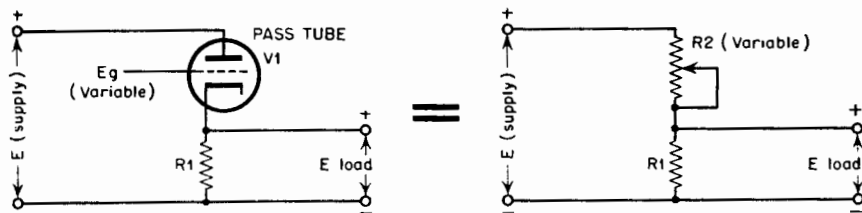

ILLUSTRATING ACTION OF PASS TUBE  
FIG. 1

quence of events is exactly opposite. The action is practically instantaneous, so that excursions are corrected for while still very small.

### Practical Design Considerations

With a working knowledge of the functions of all component parts, the design of regulated power supply equipment is no more complicated than that of other electronic circuitry usually designed and constructed by the user.

As with any power supply design, the first step is to determine the desired output voltage and current requirements. This permits the selection of the proper power transformer, filter components, and pass tube. The supply section differs from standard design only in that considerably more voltage than the required output voltage must be provided since there is an appreciable minimum voltage drop across the regulator tube. Usually the unregulated section of the supply must furnish from 50 to 200 volts more than the desired regulated output.

For a sample design, let us suppose that a regulated output of about 300 volts at 75 milliamperes is required for a general utility supply. The practical circuit for such a supply is shown in Fig. 3. Knowing the current requirement, a suitable pass tube may be selected from Table I. Any triode or triode-connected pentode capable of passing the required current at a reasonable voltage drop may be employed. Tubes may readily be used in parallel where greater current is required or when greater plate dissipation is needed. Special types, such as the 6AS7 which was designed for pass tube applications, are also available. For our present design, a smaller tube such as the 2A3 or its 6.3 volt equivalent, the 6A3, will suffice.

The power transformer and filter choke must be conservatively rated

TUBE TYPE	CURRENT (Ma.)
6AS7G	250
6A3	75
2A3	75
6B4G	75
6A5G	75
807 *	80
6L6 *	75
6V6 *	45
6F6 *	40
6Y6 *	60

\* Screen connected to plate through 500 Ohm, 1 Watt resistor

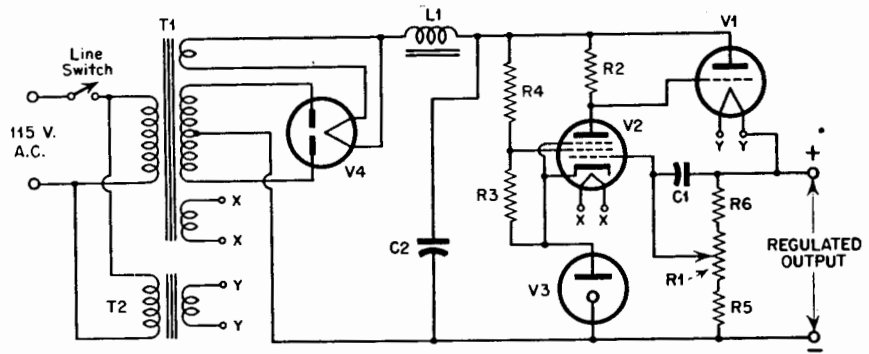

- R1, R5, R6 - See text
- R2 - .47 Megohm, 1 Watt
- R3 - 12,000 Ohms, 5 Watt
- R4 - 18,000 " " "
- L1 - Filter choke, 8 Hy., 100 Ma.
- C1 - .25  $\mu$ fd, Aerovox Type 84
- C2 - 8  $\mu$ fd, Electrolytic, Aerovox Type GL-EP
- T1 - Power Transf., 550-0-550 V. @ 100 Ma  
5V. @ 3A. and 6.3 V. @ 1A.
- T2 - Filament Transf., 6.3 V. @ 1A
- V1 - 6A3
- V2 - 6SJ7
- V3 - VR150
- V4 - 5U4G

PRACTICAL REGULATED SUPPLY  
FIG. 3

for the full load current. Otherwise, the regulation of the supply will be poor. The required voltage rating for the transformer is determined by finding the sum of the voltage drops around the circuit for the condition of maximum output voltage and current. The drop across the pass tube is minimum for maximum output voltage and may be found by referring to the plate characteristic curves for the pass tube being used. For the 6A3 used in the present design, the minimum tube drop for the required load current is about 80 volts at zero bias. Actually, somewhat greater values should be designed for to provide a margin for low line voltage conditions. For the 6A3, a minimum drop of 140 volts is typical. Thus, the d.c. output of the supply section ahead of the regulator must be about 440 volts; 300 volts for the load and 140 minimum drop across the pass tube. Reference to the rectifier tube operating characteristics will indicate the r.m.s. voltage rating of the power transformer required to supply this voltage when a single section choke-input filter is used. With the 5U4-G employed in the present design, and allowing sufficient margin for voltage drop across the choke, low line voltage, etc., a transformer delivering 550 volts each side of center-tap at 100 ma. is indicated. The choke should also be rated at 100 ma.

At this point, having selected the pass tube and determined the characteristics of the unregulated supply section, it is well to examine the pass tube operating conditions to determine if the allowable plate dissipation is being exceeded. The 6A3 is rated at 15 watts maximum dissipation. At full current and voltage from the supply, the drop across the

pass tube estimated above was 140 volts. The plate dissipation under this condition is 140v. times .075 amps. or 10.5 watts. The low voltage limit to which the supply can safely be adjusted at full current may now be determined, since the voltage drop across the pass tube, and hence its plate dissipation, is maximum at the lowest regulated output voltage. The allowable drop for 15 watts plate dissipation is now calculated as 15 watts, .075 amp. or 200 volts. With a total unregulated voltage of 440v. available, the minimum regulated output of the supply is thus 240 volts. By using a larger pass tube, or several in parallel, the range of regulated voltage adjustment can be appreciably extended.

The choice of a control tube is rather arbitrary. Almost any pentode having a sharp cut-off characteristic may be used. The type most frequently employed in electronically regulated supplies is the 6SJ7, which is chosen for its low cost, ready availability, and high gain. Miniature types having similar characteristics may be used in applications where space is at a premium. The 6SJ7 will do nicely for the design under consideration.

Although batteries may be used for the source of control tube reference bias voltage, the gaseous voltage regulator tube is usually preferred. Tubes of the "VR" series give excellent life and stabilization in this application. The choice of VR type, VR75, 90, 105 or 150, depends on the unregulated voltage available and the portion of this which must be reserved for drop across the load-bias resistor (R2) and the control tube. It is desirable to utilize the highest volt-

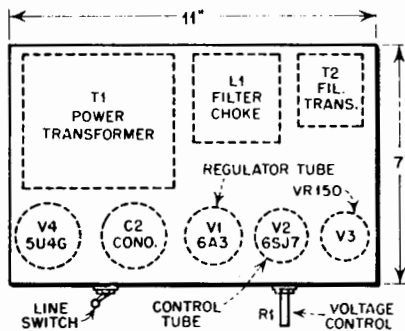

SUGGESTED PARTS LAYOUT  
FOR REGULATED SUPPLY  
FIG. 4

age VR tube possible under these conditions, since this subjects the grid of the control tube to a larger portion of output voltage fluctuations. A VR150 is sufficient for the design being discussed, since the bias developed across R2 to reduce the output voltage to minimum is only about -30 volts, as indicated by the plate curves for the 6A3. The plate load resistor (R2) is chosen to be about equal to the plate resistance of the control tube. Values between .47 and .68 megohm are typical for the 6SJ7.

The by-pass capacitor, C1, is usually about .25 microfarads. It provides a path for 120 cycle ripple voltages and other high frequency fluctuations between the regulated output and the grid of the control tube.

The dropping resistors R3 and R4 are designed to provide 150 volts across the VR tube at the 8 ma. minimum current required for regulation and to provide a tap for control tube screen voltage. In computing the values of these resistors, the minimum

unregulated supply output voltage must be used. Allowing for 10% drop in line voltage, this would be 396 volts in the present case. The required drop is then 396 minus 150 or 246 volts. At .008 ampere drain, the total resistance required (R3 and R4) is  $246/.008$  or 30,750 ohms. The portion of this resistance between the cathode and screen of the control tube to furnish a screen voltage of 100 volts should be  $100/.008$  or 12,500 ohms. Thus the nearest standard values of 12,000 and 18,000 ohms will suffice for R3 and R4 respectively.

The total resistance value for the output bleeder is usually about .25 megohm, made up of a 50,000 wire-wound potentiometer for the voltage output adjustment and fixed carbon resistors (R5 and R6) above and below it to complete the total. The exact values of these for any particular regulated supply are most easily determined experimentally by substituting a .25 megohm potentiometer temporarily in place of R1, R5 and R6. Then, with the supply operating, the settings of the potentiometer tap for the minimum and maximum output voltages allowable under full load conditions can be determined. The potentiometer is then disconnected and the resistances measured with an ohmmeter. The resistance between the slider position for low voltage output and the ground end of the "pot" is the value for R5. Similarly, the resistance measured between the slider setting for high output voltage and the "hot" end of the potentiometer is the value for R6. The correct value for R1 is then R5 plus R6 subtracted from .25 megohm.

### Construction

Standard power supply wiring practices apply to all portions of the regulated supply except the control tube section. Since this tube is acting as a high gain d.c. amplifier, it is very susceptible to hum pick-up which will appear as ripple in the output voltage. To minimize this, all leads associated with the control tube, and especially the grid lead from R1, must be as short as possible. The best practice is to mount the voltage control potentiometer adjacent to the control tube socket at a location as far as possible from the power transformer, filter chokes, filament transformers, and other components which produce hum fields.

A chassis lay-out which is suitable for the design discussed above is shown in Fig. 4. All parts are mounted on a 7 x 11 x 2 inch metal chassis. Well-shielded components should be used and all a.c. leads must be twisted in pairs to reduce hum radiation. A separate filament winding is required for the regulator tube since the filament of this tube is operated at the full supply output voltage above ground. When the special 6AS7G pass tube is used, this precaution is not necessary because the heater-cathode insulation in this tube is sufficient to withstand 300 volts.

The completed supply should be checked for satisfactory regulation by varying the load current from the full design rating to zero. Under these conditions, the change in output voltage should be negligible. Ripple content can be checked qualitatively with earphones coupled through a suitable condenser, although an oscilloscope is very much preferable.

## Ferroresonant Circuits

If a saturable reactor is made the inductive element of a tuned circuit, either series-resonant or parallel-resonant, varying the current through the reactor will vary the resonant frequency of the combination. This is the simple basis of all ferroresonant circuits. The most efficient manifestation of this effect occurs when a large resonant frequency shift is obtained as the result of a small change in control current, usually through a separate winding. The ferroresonant effect may be utilized in various ways in electronic and electrical equipment.

Ferroresonant circuits recently have been designed to perform as amplifiers, triggers, switches, flip-flops, gates and oscillators. Ferroresonant elements find application in electronic counters, computers and other digital devices, frequency dividers, signal amplifiers, and automatic control circuits. Closely related to the magnetic amplifier, the ferroresonant circuit is tubeless and has unlimited life. Ferroresonant elements are rugged and can be made extremely small in size. Unlike the magnetic amplifier, ferroresonant devices may be operated

at high supply-voltage frequencies, enabling high-speed switching performance and high-frequency amplification.

### Basic Ferroresonant Circuit

In Figure 1, a coil having a saturable core is connected in series with a conventional capacitor, resistor, and continuously variable a-c source. This is the basic ferroresonant circuit. The zero-current inductance of coil L and the capacitance C are chosen such that the series-resonant frequency,  $f_s$ , of the

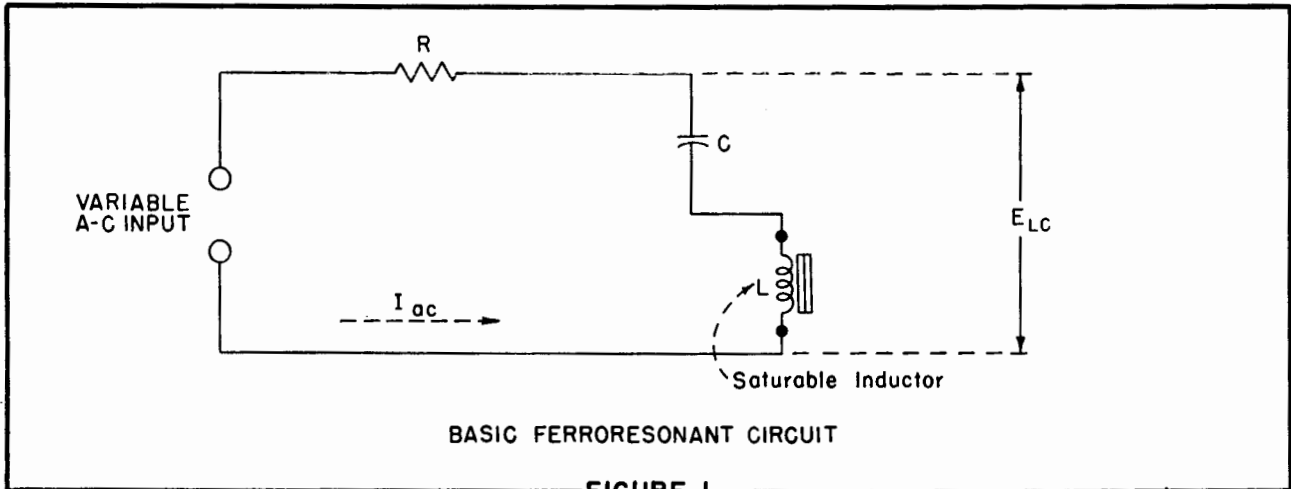

—FIGURE 1.—

combination is somewhat lower than the supply-voltage frequency.

Figure 2 shows the response of this simple circuit. As the supply voltage is increased, the current ( $I_{ac}$ ) through the coil, capacitor, and resistor increases, as shown in Figure 2(B), and the voltage ( $E_{LC}$ ) across the inductance-capacitance leg increases from zero to a maximum at point A. As the current is increased beyond this level, voltage  $E_{LC}$  would continue to increase except that the core of the coil begins to saturate and this lowers the inductance. Accordingly, the voltage begins to fall after point A.

The decreasing inductance of the coil causes the circuit to approach resonance, the impedance of the LC arm decreasing. The voltage drop  $E_{LC}$  accordingly decreases, dropping to point B at resonance. Although  $X_L = X_C$  at this point, B does not dip completely to the zero-voltage line because of resistive losses, chiefly in the coil.

As the current is increased beyond this point, further saturation of the core and consequent lowering of the inductance tunes the circuit beyond resonance, and voltage  $E_{LC}$  again rises, as from B to C. Figure 2(A) shows the variation of circuit reactance with current. At resonance, the voltage drop,  $IR$ , is due only to resistive losses mainly in the coil copper. Before this point, the circuit reactance is inductive, and after this point is capacitive.

The plot of Figure 2(B) is seen to have the S-curve shape which is typical of the characteristics of certain bistable and oscillating systems. Thus, the response is characterized by two stable regions of "positive impedance" (OA and BC) connected by an unstable region of "negative impedance" (AB).

This circuit can exhibit true bistability. That is, its current may have either a high or a low discrete value at a particular voltage, and this current value can be maintained indefinitely unless the operator switches it to its second value. Thus, referring to Figure 2(B), the current might have a low value X or a high value Y along the inscribed non-linear load line. The current will not hold along the unstable negative slope, AB, but can be made to shift from some point along OA to a point along BC, quickly traversing AB and locking along BC. If the ferroresonant element is operated in a suitable circuit, conduction may be triggered back and forth between the two stable states. This action suits the ferroresonant element ideally as a binary device.

#### *Ferroresonant Flip-Flops*

One of the most promising and already exploited applications of

small ferroresonant elements is as flip-flops in digital computers, counters, and frequency dividers.

A second, coupled winding might be added to the simple circuit of Figure 1. This modification is shown in Figure 3. Here, the control winding actually consists of two coils ( $L_1$  and  $L_2$ ) which are connected series-bucking to isolate the TRIGGER INPUT terminals from the a-c supply. A d-c trigger pulse of either polarity applied to the control winding then would reduce momentarily the inductance of  $L_3$  and allow the current to jump from X (Figure 2B) to Y. The current then would latch at the second value and would be unaffected by further pulses applied to the control winding, since the high current at point X would be sufficient to maintain the core saturated.

The fact that the current in this simple circuit cannot be returned to

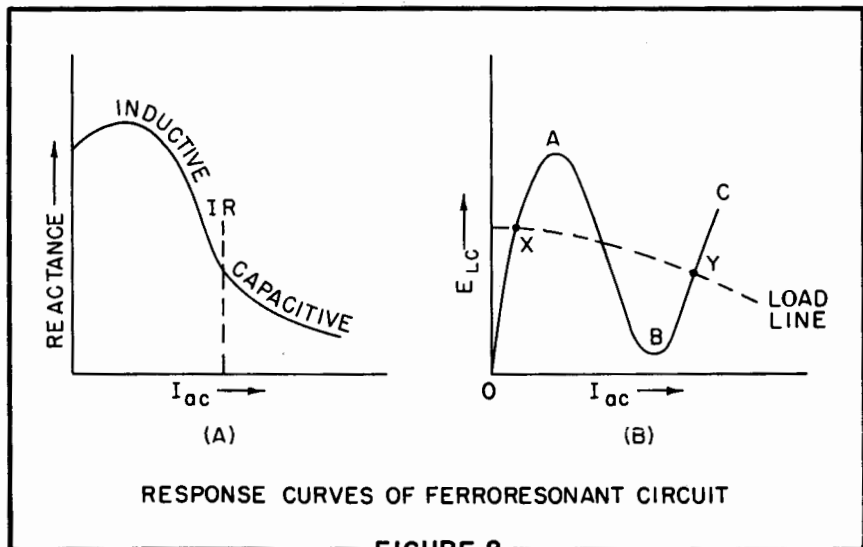

—FIGURE 2.—

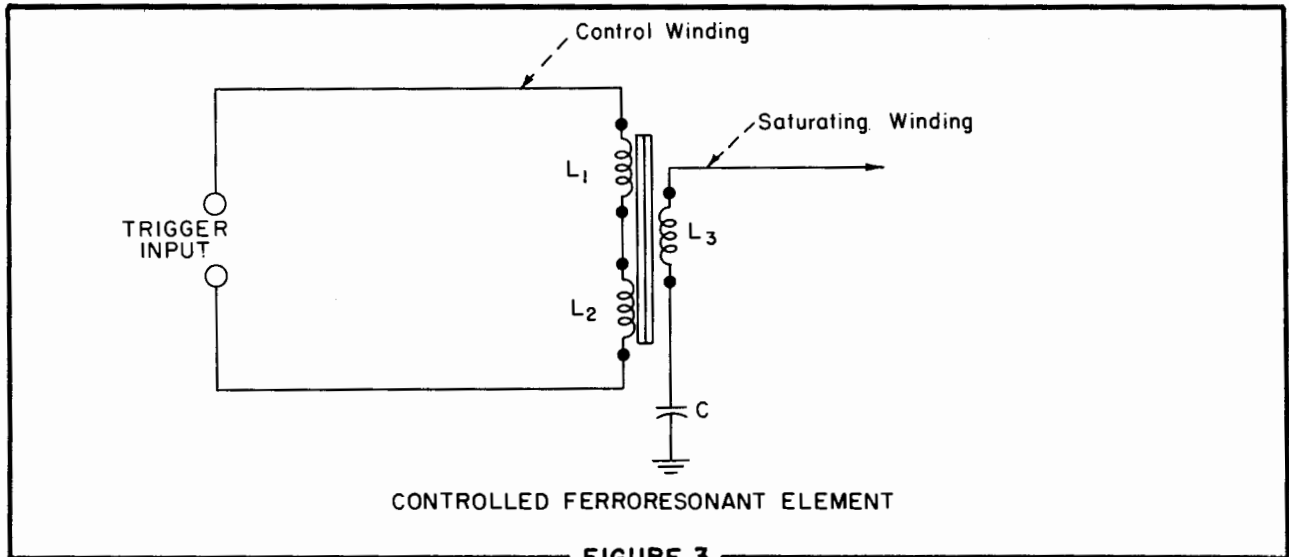

**FIGURE 3.**

its initial level by alternate pulses but only by a momentary interruption of the a-c supply line prevents use of the circuit directly as a flip-flop even though it is bistable.

Figure 4 is an arrangement of two ferroresonant elements in parallel. Each has a separate control coil. This arrangement provides good flip-flop action. The circuit is due to

Isborn. Here,  $L_3C_2$  and  $L_4C_3$  correspond to the simple elements shown previously in Figure 1. Capacitor  $C_1$  provides a series reactance which is common to both ferroresonant legs. The control winding for the left leg consists of coils  $L_1$  and  $L_2$  connected in series-bucking to prevent transmission of the a-c supply energy back to the INPUT 1 terminals. Similarly,

the control winding of the right leg consists of  $L_5$  and  $L_6$  connected in series-bucking to prevent a-c coupling back to the INPUT 2 terminals.

With the proper magnitude of reactance at  $C_1$ , only one ferroresonant leg can conduct in the high-current state at one time. If both legs should attempt to operate at this level simultaneously at high current, the in-

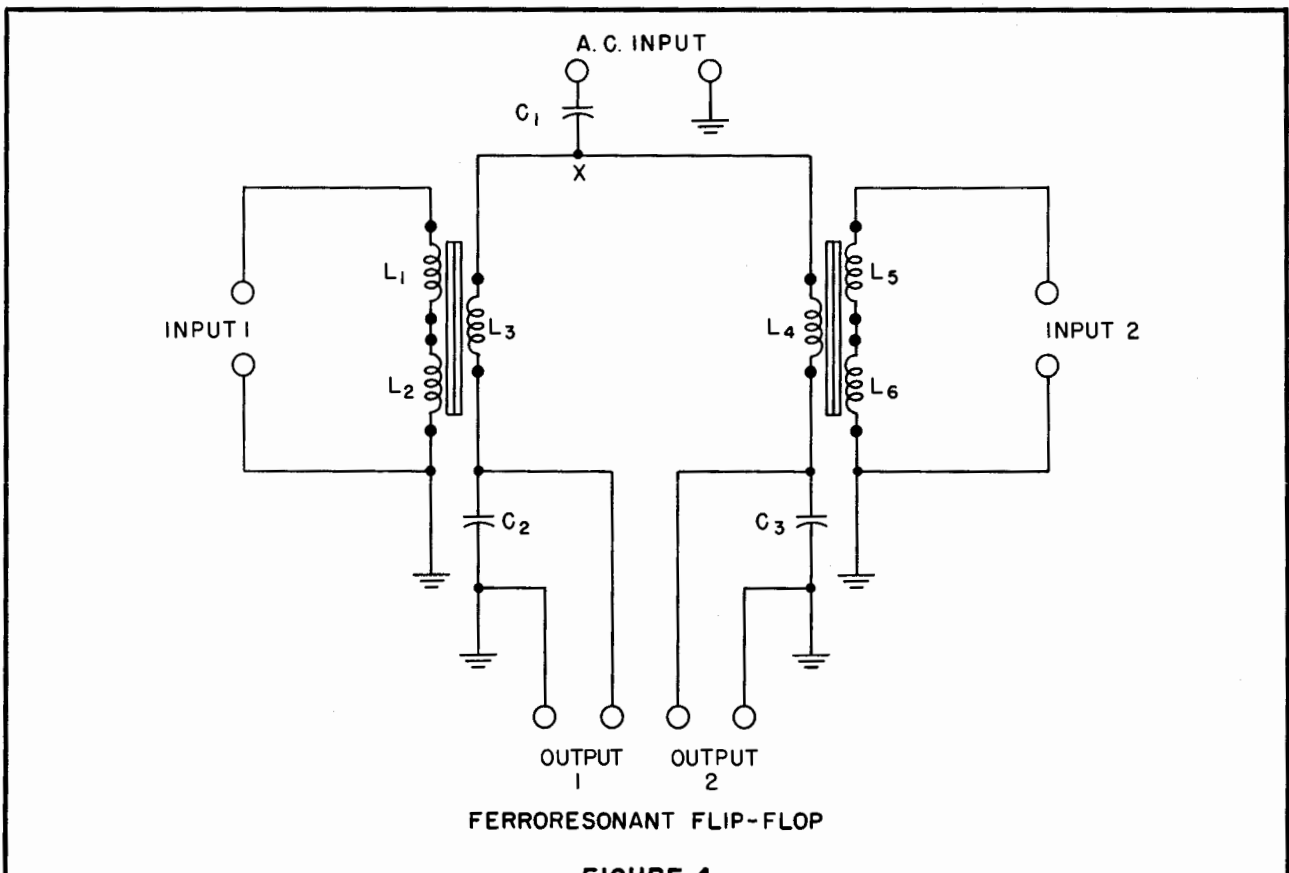

**FIGURE 4.**

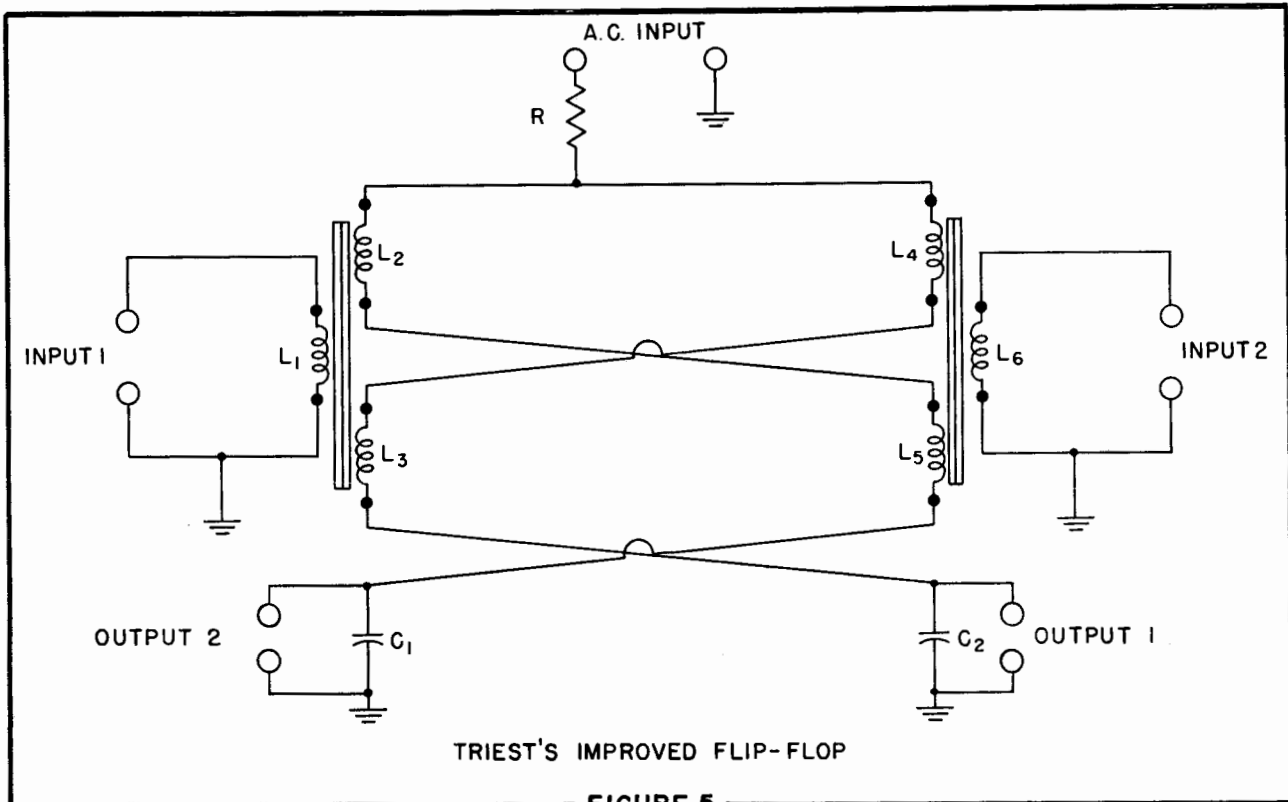

FIGURE 5.

creased voltage drop at point X would reduce the leg drops ( $EL_3C_2$  and  $EL_4C_3$ ) below the resonant value and neither one could latch-in at high current. When both legs drop to low-current conduction (or attempt to do so), the drop across  $C_1$  falls and the voltage at point X rises to such a high value that either the left or right leg will "fire."

In order to examine operation of this circuit, assume that the left leg ( $L_3C_2$ ) is conducting high and that the right leg ( $L_4C_3$ ) is conducting low. Output 1 will be high (TRUE or 1 in binary notation) and output 2 will be low (binary FALSE or 0). A pulse applied to INPUT 1 will have no effect, since the core already is saturated in this leg of the circuit. Coil  $L_4$ , however, is carrying low current and its core is not saturated. A pulse applied to INPUT 2 therefore will lower the inductance of  $L_4$ , saturating the core of this coil and moving the  $L_4C_3$  leg into resonance. The high current then will reduce the voltage at point X momentarily to such an extent that  $L_3C_2$  is detuned from resonance and drops to the low current condition. High conduction then shifts to the right leg, and OUTPUT 2 becomes high. Thus, the two outputs always are of opposite phase and change states with respect to each other.

For single-input operation, INPUT 1 and INPUT 2 may be connected together and the triggering pulse thus applied simultaneously to  $L_1L_2$  and  $L_5L_6$ . Successive pulses then will cause high conduction to flip back and forth between the two legs, and a given pair of OUTPUT terminals will have high output during only half of the number of input pulses.

The circuit thus acts as a frequency halver.

Appreciable power gain is obtained. Rutishauser has pointed out that by providing control coils of many turns, the required triggering current can be made very small. One flip-flop thus can drive others without intermediate driver stages. In this way, it is comparatively simple to set up tubeless binary counters, ring counters, and similar circuits. Rutishauser has had a ring of 32 stages operating satisfactorily and states that about 50 stages would appear to be the upper limit.

Aside from being tubeless, simple, and capable of extreme miniaturization, ferroresonant flip-flops with small cores of thin material may be operated at high power-supply frequencies (1 Mc and higher) allowing rapid switching. Isborn mentions that the entire switching operation takes place in a period equal to approximately 5 cycles of the supply frequency. Another considerable advantage of the ferroresonant flip-flop is its low power requirement. This results from the use of reactive components in the circuit. Furthermore, although high current is shifting from one leg to the other, the load on the power supply is constant. Another advantage is the low heat radiation which results from low power dissipation and the absence of tube filaments.

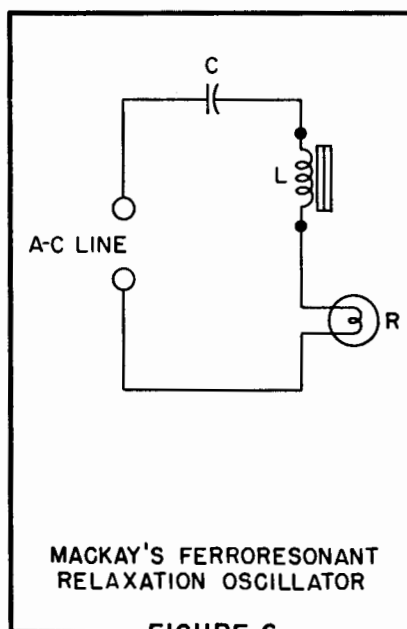
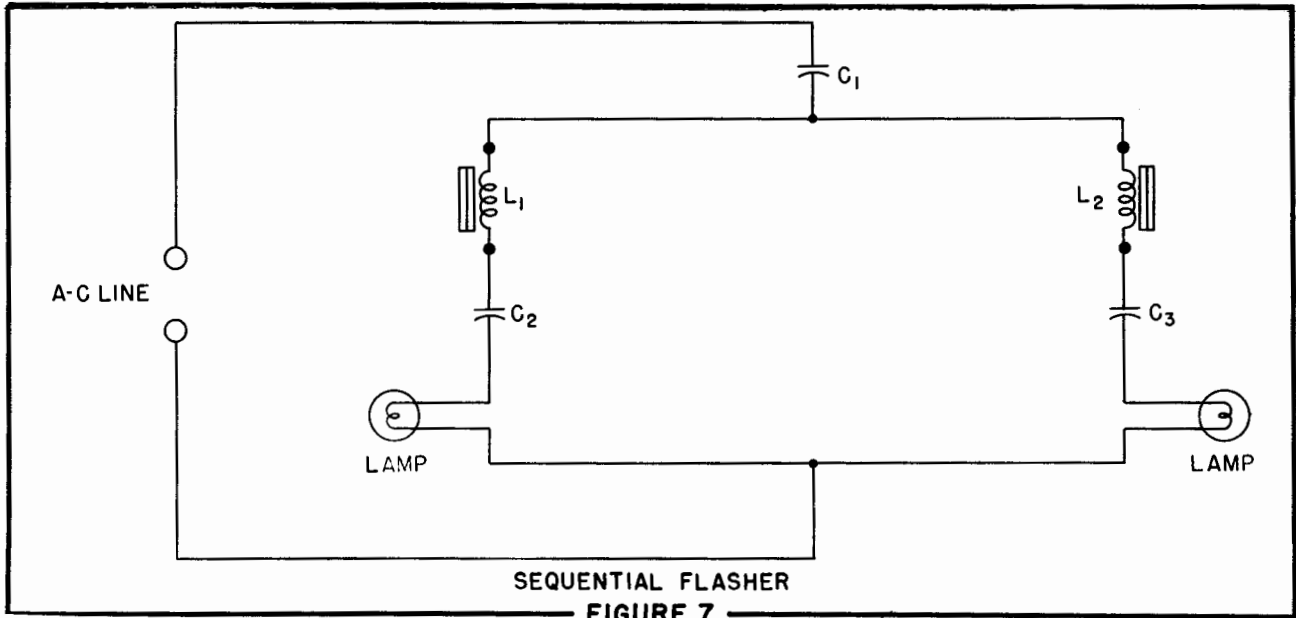

FIGURE 6.





Triest of International Business Machines Corp. has patented an improved ferroresonant flip-flop, shown in basic arrangement in Figure 5. This circuit employs a pair of saturating windings ( $L_2L_3$  and  $L_4L_5$ ) on each core and cross-couples them.

A low, lagging current flows in the less saturated leg and a high, leading current in the more saturated leg. The patent claims that the cross coupling increases the difference between the two current magnitudes, creating in fact a wide gap. The common resistance,  $R$ , in Figure 5 serves the same purpose as the common capacitance,  $C_1$ , in Figure 4.

The main saturable inductor windings are  $L_2$  and  $L_4$ . Coils  $L_3$  and  $L_5$  are the auxiliary windings. When the left leg is resonant, high leading current in  $L_5$  produces flux in the core of the right leg to induce an e. m. f. in  $L_4$ . This voltage opposes the lagging current in  $L_4$ . The net result of this action is a reduction of the current in the right leg and an increase in the current in the left leg. It is in this way that the gap between the values of voltage drop across capacitors  $C_1$  and  $C_2$  is widened. Outputs are taken from across these two capacitors.

#### Additional Applications

Mackay has developed several interesting circuits of a highly practical nature in which ferroresonant elements are combined with the non-linearity of tungsten lamp filaments to obtain relaxation oscillations and

the intermittent operation of lamps. This scheme has been described also in the popular literature.

Figures 6 and 7 show two of Mackay's circuits. In Figure 6,  $L$  is the primary winding of a small filament transformer (Stancor P-6135) and serves well enough as a saturable reactor at the current levels involved.  $C$  is a 12-microfarad capacitor (non-electrolytic) and  $R$  is a 100-watt lamp. The latter exhibits low resistance (high current) when its filament is cold, and high resistance (low current) when hot. The  $L$  and  $C$  combination behaves like the simple ferroresonant circuit shown in Figure 1 when the current is high enough to start saturation of the coil,  $L$ . The circuit is operated from the 115-volt ac power line through a variable autotransformer such as a Variac.

When the circuit is switched-on, the filament is cold and its resistance low. The lamp accordingly lights from the correspondingly high current flow and the ferroresonant circuit operates at its high-current point. As the filament heats, its resistance increases, the current accordingly drops and will snap (flip-flop fashion) to the low-current point on the ferroresonant response curve. The lamp therefore extinguishes. As the filament then cools, its resistance decreases, current again rises and soon snaps back to the high-level point to repeat the cycle of operations. When the input voltage is adjusted to a certain critical point, the lamp flashes on and off at a

regular rate as the result of this ferroresonant action. Mackay gives a 5½-second ON rate with the circuit constants shown here.

The circuit shown in Figure 7 will be seen to resemble the ferroresonant flip-flop of Figure 4, minus control (trigger) windings. It consists of two "blinker" circuits of the type just described, with the addition of the common capacitor,  $C_1$ . In this circuit,  $L_1$  and  $L_2$  are the primary windings of small filament transformers, as before, and  $C_1$  is a 16-microfarad non-electrolytic capacitor.  $C_2$  and  $C_3$  each are 12 microfarads, also non-electrolytic. Each lamp is of 100-watt size. Both lamps cannot light simultaneously because the large voltage drop across  $C_1$ , due to the resulting high current flow, would reduce the voltage across each leg of the circuit to a value much lower than the ferroresonant value and insufficient to light the lamps. However, one leg always will have enough voltage for the lamp in that leg to glow. When that lamp extinguishes, the one in the other leg ignites. Mackay has operated a number of legs through the common capacitor and observed that the lamps flash cyclically.

An obvious application of this low-frequency type of ferroresonant circuit would be as a high-intensity blinker in such applications as traffic signal beacons, railroad signals, etc. where all moving parts, relay contacts, and the like would be eliminated and continuous, unattended operation secured.

## SECTION III COMPONENTS

# Fixed Capacitors in Modern Circuitry

NO other electrical component is called upon to perform such a wide variety of functions in electronic circuits as the capacitor. Most of these applications are based upon the ability of the condenser to differentiate between electrical currents of various frequencies. Such applications include; d.c. blocking, ripple filtering, r.f. and audio by-passing, coupling, frequency determination, R-C timing, and energy storage. Because of the varied requirements of these uses, fixed capacitors are made in many types and sizes, each especially engineered to fulfill a specific application or function. An important part of modern circuit design is therefore the choice of the proper capacitor for the circuit application at hand. In many cases, the success or failure of the design will actually depend upon this choice. The radio engineer, experimenter, and amateur must therefore have a firm background in capacitor design and application.

Probably the most direct route to a mastery of the "safe and sane" use of capacitors is to establish a thorough understanding of the characteristics and limitations of each general type. The choice of the proper type for each circuit application then becomes merely a matter of following good engineering practice. For this reason, we will commence with a discussion of the basic types of fixed capacitors which are encountered in electronic circuitry.

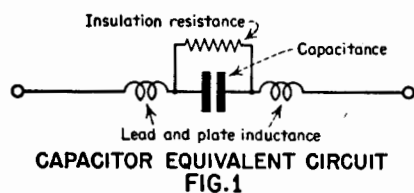

Since a capacitor is fundamentally two metallic conducting sheets isolated by a suitable dielectric material, the basic types are classified according to the type of dielectric used. They include:

- Air Dielectric Capacitors
- Mica Capacitors
- Ceramic Capacitors
- Paper Capacitors
- Electrolytic Capacitors

Just as all inductances have distributed capacity and resistance, and everyday resistors have some inductance and "end-to-end" capacitance, practical condensers are not perfect capacitances. All have a certain amount of residual inductance associated with the leads and plates, and also a finite value of resistance called the "insulation resistance". Thus, the equivalent circuit of any capacitor can be considered as in Fig. 1. The magnitudes of these unwanted characteristics vary through wide limits as a function of mechanical design and type of insulation or "impregnant" used, and must be considered along with such other characteristics as capacitance value, voltage and current ratings, temperature coefficient, stability, etc., in selecting a condenser for a particular job. The actual choice is usually a compromise between mechanical and electrical perfection on one hand, and the dictates of economy, space, and the practical requirements of the application on the other.

### The Air Dielectric Capacitor

From the standpoint of low losses (high capacitor) and constancy of capacity value, the most nearly ideal capacitors are built with air (or vacuum) as the dielectric between the plates. Such capacitors are not perfect, however, for although air is a

perfect dielectric having zero power factor, some losses arise due to dielectric hysteresis in the insulating material used to support the plates. Charging currents flowing in the leads and plates cause additional power losses and give rise to some residual reactance.

The air-dielectric condenser occupies much more volume for a given capacitance and is usually more expensive than any of the other general types. The reasons for this are apparent from an inspection of one of the simpler empirical formulas for the capacitance between parallel plates whose dimensions are large compared with the spacing between them, so that "fringing" may be neglected:

$$\text{CAPACITANCE } (\mu\text{fds}) = .2244 K \frac{A}{d}$$

Where: K is the dielectric constant of the material between plates.  
A is the area of the smallest plate. (Sq.In.)  
d is the distance between the plates (In.)

From this it is seen that the capacitance is *directly* proportional to the dielectric constant and the plate area, and *inversely* proportional to the spacing. Since the dielectric constant of air is only 1.0, but is greater than unity for all other insulating materials used in condenser construction, greater areas must be used in air capacitors to achieve a given capacitance. In addition, the dielectric strength of air is considerably lower than that of the other dielectrics, so that greater electrode spacings are necessary for a given working voltage. As a result, the volume occupied by an air-dielectric condenser will be at least 500 times greater than that of a comparable capacitor using a high grade mica dielectric.

Because of these factors, air as a dielectric is used only to a very limited extent in fixed capacitors, such as in certain laboratory capacitance standards. Fixed capacitors using vacuum or an inert gas under pressure are used to a greater extent, since the breakdown voltage is increased about four to ten times thereby. Air dielectric *variable* capacitors are, of course, widely used for tuning r.f. circuits because of their mechanical simplicity.

#### Mica Capacitors.

Mica is widely used as the insulating material in capacitors manufactured primarily for r.f. applications. The mica capacitor is characterized by low power factor, high puncture voltage, good stability, high insulation resistance, and reasonable cost. As mentioned above, the size for a given capacity is considerably smaller than that of a comparable air-dielectric condenser. Due to the stacked construction usually employed, the inductance is quite low. A common construction is illustrated in Fig. 2. The plates consist of metal foil sandwiched between thin sheets of mica dielectric material. The ends of alternate foil strips extend beyond the mica sheets at opposite ends of the stack and each group is clamped together and connected to a lead. Thus, the charging currents which flow into each plate do so through a relatively short, broad path. Therefore, the inductance is low, being mainly that contributed by the wire leads.

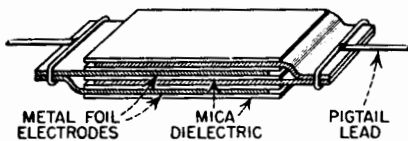

TYPICAL MICA CAPACITOR CONSTRUCTION  
FIG. 2

Mica capacitors are used in a multitude of electronic applications where a high degree of capacitor excellence is required. Such uses include; r.f. fixed tuned circuits, r.f. by-passing, r.f. coupling, d.c. blocking, r.f. neutralizing, r.f. filtering, a.f. tone control, a.f. degenerative feedback, a.f. coupling where high insulation resistance is important (as in certain RC-coupled amplifiers), and many others.

In radio frequency applications, mica capacitors are rated according to r.f. current handling capability as well as maximum instantaneous voltage. The observance of both of these ratings are equally important in prac-

tice. Excessive r.f. current results in capacitor heating, which, in turn, causes increased dielectric losses, capacitance deviation, and lowered breakdown voltage. The effect is thus cumulative. The r.f. current through a capacitor in any given application can be determined by connecting a suitable r.f. thermoammeter in series with it.

In applications where stability of capacitance value is important, as in tuned circuits, r.f. filters, and other critical circuits, capacitors of the "silvered mica" variety are used. These units have extreme capacitance stability and low temperature coefficients. These excellent characteristics are obtained by depositing a silver coating on the opposite surfaces of mica wafers and "sintering" this assembly at high temperature to form highly conducting metal "plates" in intimate contact with the mica. The variable factor of stacking pressure is thus drastically reduced, with correspondingly improved stability.

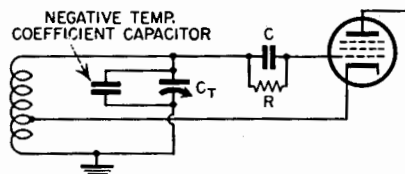

USE OF TEMPERATURE COMPENSATING CAPACITOR  
FIG. 3

High quality mica units are manufactured with either positive, zero, or negative temperature coefficients of capacitance. Capacitors of this type can be used for temperature compensation in tuned LC circuits in which low frequency drift with ambient temperature change is important. By such means, self-excited r.f. oscillators having frequency stability comparable to crystal controlled oscillators can be built. Stabilized oscillators of this type are used for receiver local oscillators, amateur v.f.o.'s, power oscillators where crystal control is impractical, etc. An example of the application of temperature compensating mica capacitors is given in Fig. 3. Here it is desired to maintain the LC product (and hence the frequency) of an R.F. oscillator "tank" circuit at a constant value over a wide temperature range. This may be accomplished by determining the approximate temperature coefficient of the uncompensated circuit in terms of capacitance deviation in parts per million per degree Centigrade. This coefficient will usually be positive with common circuit elements, i.e., the frequency decreases with increasing temperature. Temperature com-

ensation then consists of the selection of a capacitor having a *negative* temperature coefficient approximately equal to the *positive* characteristic of the other circuit elements. Thus, with all circuit elements subjected to the same ambient temperature changes, frequency "drift" is compensated. A trick frequently resorted to by circuit designers consists of placing the compensating capacitor at a location in the equivalent where a temperature gradient exists, such as near a vacuum tube. A "vernier control" of temperature compensation is then obtained by adjusting the position of the capacitor within this gradient by trial and error until a point of best frequency stability is located.

#### The Ceramic Capacitor

Another type of condenser which in some cases is comparable to the mica capacitor in electrical characteristics uses a ceramic as the dielectric material. A typical design is shown in Fig. 4. The capacitor plates are deposited on the inner and outer surfaces of a ceramic tube with connecting leads at either end. This unit is then sealed in a second ceramic tube and the whole assembly is wax impregnated for moisture proofing.

Ceramic capacitors are manufactured in a wide variety of characteristics, depending upon the type of ceramic used for the tube upon which the electrodes are deposited. Since some of the ceramics have very high dielectric constants, the volume efficiency (micromicrofarads, cubic inch) is high. Titanium dioxide ceramics, for instance, are used extensively for their high dielectric constants (90-170), low losses, and low temperature coefficients. Since the temperature coefficient can be controlled by the ceramic mixture, units ranging from essentially zero to high negative values of temperature coefficient are available for temperature compensation. Due to the coaxial type of construction, tubular ceramic capacitors have low values of residual inductance.

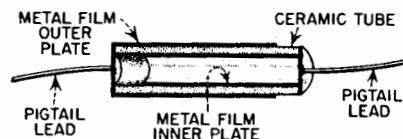

CERAMIC CAPACITOR CONSTRUCTION  
FIG. 4

One grade of ceramic capacitor is used interchangeably with mica capacitors in critical r.f. circuits, while a lower quality variety which has

very high volume efficiencies but poor stability, is used for general purpose applications such as by-passing. Ceramic tubular capacitors are usually more expensive than equivalent mica units. However, disk type ceramic capacitors are less expensive than equivalent mica capacitors and are sold on a "guaranteed minimum value" basis. Disk ceramics are used in high frequency by-pass applications only.

#### Paper Capacitors

Capacitors using wax or oil impregnated paper dielectric are employed extensively in d.c., audio, and low frequency r.f. applications where high capacitance per unit volume and low cost is required. They are characterized by generally poorer electrical characteristics than mica or ceramic capacitors, including; higher power factor, larger temperature coefficients, lower operating voltages, higher inductance and shorter life. These factors depend to a large extent upon the type of impregnant used, the purity of the impregnant, the method of construction, and the casing employed.

Wax is used as the impregnant in a large variety of utility capacitors for the lower voltage ratings, where small size and economy are important. The tubular capacitors used in receiver audio, blocking, and by-pass work are examples. Moisture absorption shortens the life of cardboard-cased wax capacitors to some extent, as does high ambient temperature. Castor oil, mineral oil, and chlorinated synthetic oils such as "askerels" are used in paper capacitors for higher operating voltages and greater dependability. Mineral oil filled units have the best temperature characteristics and lower power factors, but are about 35% larger in volume because of the lower dielectric constant. For this reason, castor oil filled condensers are used in most noncritical applications or where space is at a premium.

Typical paper condensers have temperature coefficients of capacitance

approximately ten times larger than high grade mica capacitors, such as the silvered-mica types. Power factors are greater by at least one order of magnitude and inductances are larger, especially in the types using paper-foil rolled construction in which the contact tabs are at the ends of the rolled foil plates. In paper capacitors of advanced design, residual inductance is minimized by the use of the extended electrode construction, in which electrical contact is made at the edges of the rolled electrodes, so that charging-current paths are short.

In applications where a wide range of frequencies must be effectively by-passed, as in the TV line filter shown in Fig. 5, a high capacitance paper capacitor may be used in parallel with a small mica unit. Otherwise, the residual inductance of the paper condenser may make it ineffective as a by-pass for the high r.f. frequencies.

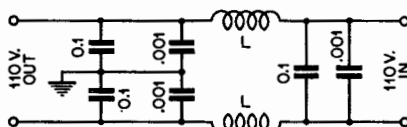

ILLUSTRATING USE OF DUAL BY-PASSING  
FIG. 5

Another by-passing device used in video i.f. amplifier design consists of using capacitors which are *self-resonant* at the frequency to be by-passed. A value of capacitance is chosen which is series resonant with the inherent inductance of the capacitor and its leads. This type of single-frequency by-passing is very effective.

#### The Electrolytic Condenser

The familiar electrolytic capacitor is the "work horse" of the receiver power supply filter field. These units have extremely high volume efficiencies, occupying only about 15% of the space required for equivalent paper capacitors. The cost per microfarad is also very low. For these reasons, although inferior in most other

respects to the other types, the electrolytic capacitor is extensively used for filter and by-pass applications.

An electrolytic capacitor may be made either by immersing two aluminum electrodes in an electrolytic solution such as ammonium borate or sodium phosphate (a "wet" electrolytic) or by filling the space between rolled foil electrodes with a thick paste of similar material (the "dry" electrolytic). A "forming voltage" applied between the plates deposits a film of aluminum oxide on the positive plate. See Fig. 6. This film is the dielectric material of the capacitor. Because it is extremely thin—being only .000025 inch thick in some cases—the capacitance per unit area is very high. For the same reason, the operating voltage of the unit is limited to about 450 volts. Electrolytics may, however, be used in series for higher voltages with the use of the usual voltage equalizing resistors shunting each unit, as must be used with mica and paper capacitors which have higher insulation resistances.

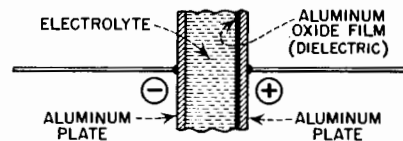

ELEMENTARY ELECTROLYTIC CAPACITOR  
FIG. 6

The electrolytic condenser is essentially for d.c. applications, since to maintain the oxide film, the plate bearing it must never become negative. If a.c. components are present, they must be smaller in voltage than the steady d.c. voltage impressed.

The high leakage current of the electrolytic becomes much greater after prolonged inactivity, but soon drops to a normal value of about 200 microamperes per microfarad. The wet electrolytic has been used in voltage limiting applications because of its particularly steep leakage-current versus applied voltage characteristic.

## Proper Use of By-Pass Condensers

IN modern electronic circuits the capacitor is used more frequently for the function known as "by-passing" than for any other single application. The selection of a capacitor of the proper type and value for a given job is an important aspect of circuit design. Such critical performance char-

acteristics as frequency response, phase distortion, circuit stability, and freedom from parasitic oscillations are determined by the by-passing used. This discussion is intended to provide a review of this subject for the benefit of the amateur, experimenter, young engineer, or anyone

who has been puzzled by the problem of what by-pass to use for a specific purpose. The factors underlying the choice of capacitors in typical circuits will be pointed up by the use of examples.

"By-passing" can be defined as providing a short, low impedance path

around certain circuit components for electrical currents of some frequencies, while maintaining a high impedance path for other frequencies. The circuit designer is repeatedly confronted with the need of components having this property of passing currents of a desired periodicity while excluding others. Actually, both inductances and capacitors qualify under this definition because of the frequency discriminating action of these simple filters. An inductance, or "choke", may be considered to be a low frequency by-pass element since it presents a low impedance path for d.c. and low frequencies while presenting a high reactive impedance for high frequencies. The condenser, on the hand, is a simple high-pass filter, having a high reactance at low frequencies and becoming more nearly a short circuit as frequency is increased. It is when this latter property is used to provide a "detour" around some part of a circuit that the term *by-passing* is most commonly employed.

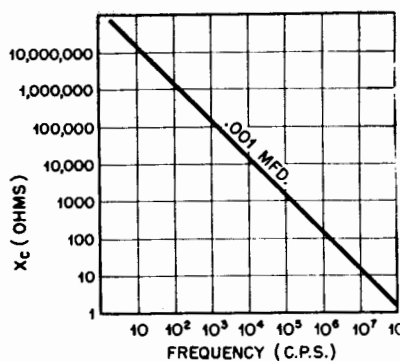

FIG. 1

For a capacitor to function as an effective by-pass, its impedance must be much lower than the impedance of the circuit element being by-passed. Of course, the reactive impedance of a capacitor of any value is easily calculated for any given frequency from the basic expression:

$$(1) \quad X_c = \frac{1}{2\pi f C}$$

Where:

- $X_c$  is the capacitive reactance in ohms
- $f$  is the frequency in cycles per second
- $C$  is the capacitance in farads

Provided that  $X_c \gg X_L$ ,  $X_L =$  lead reactance.

Needless to say, this relationship is of constant use in designing proper by-pass circuits. It shows that the reactance of a given unit decreases with frequency or that, for a given frequency, a value of capacity can be chosen to give any desired value of

capacitive reactance. To aid in visualizing this function, we have plotted the reactance of a .001 mfd. condenser versus frequency in Fig. 1.

#### Cathode Resistor By-Passing

The most frequent use of the by-pass condenser is illustrated in Fig. 2, where the capacitor is used as a *cathode resistor by-pass*. The necessity for this is obvious when the characteristics of the circuit are considered. As is well known, any vacuum tube stage which uses cathode bias exhibits strong degeneration if the signal current is allowed to flow through the bias resistor. This is so, as the a.c. component of the plate current flowing through the bias resistor develops a voltage drop across it during signal peaks which increases the bias applied to the grid of the tube. This has the effect of reducing the signal voltage on the tube grid and thus reducing the stage gain and introducing phase distortion and other undesirable results.

In Fig. 2, this degenerative effect is prevented by shunting the cathode bias resistor with a capacitor which by-passes the a.c. signal component around it. Let us now consider the requirements placed upon this capacitor.

Assume that the stage depicted in Fig. 2 is an audio amplifier intended to work over the frequency range of 200 to 5000 c.p.s. and that the cathode resistor recommended for the tube type used is 300 ohms. A by-pass capacitor must be provided across this resistance which will prevent most of the audio frequency plate signal current from flowing through it. Since the reactive impedance of the condenser becomes lower with increasing frequency, as shown by Eq. 1, one which is satisfactory at the low frequency end of the desired range will do for the entire range. Therefore, in the present example, a capacitor which effectively by-passes the 300 ohm cathode resistor at 200 c.p.s. should be adequate. Most circuit designers consider a ratio of bias resistance to by-pass reactance of about 10-to-1 to be a safe rule-

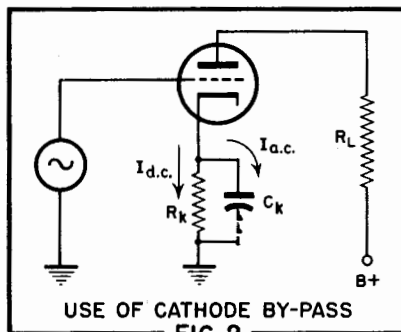

of-thumb for most work. With this ratio more than 99% of the total a.c. current flows through the by-pass condenser. Ratios up to 20-to-1 may be used in high fidelity amplifier work where space and economical considerations permit, however.

Assuming a by-pass ratio of 10-to-1 to be sufficient, a capacitor having a reactance of one-tenth the resistance of the bias resistor at 200 c.p.s. is necessary. By rewriting Eq. 1 to solve for a value of capacitance having a reactance of 30 ohms, an answer of 26 microfarads is obtained. Therefore, the nearest standard value of 25 microfarads would be used. An electrolytic condenser is usually used in this application since leakage resistance is not important in this case and these units are compact and economical. The capacitor must be rated for a working voltage greater than the maximum bias voltage developed. This may be obtained from Ohm's Law, using the bias resistance and the maximum d.c. current which flows through it. For pentodes, this means both the plate and screen current, and for classes of amplification other than Class A requires the maximum-signal current. A voltage rating of 25 or 50 volts is usually sufficient for cathode by-passing.

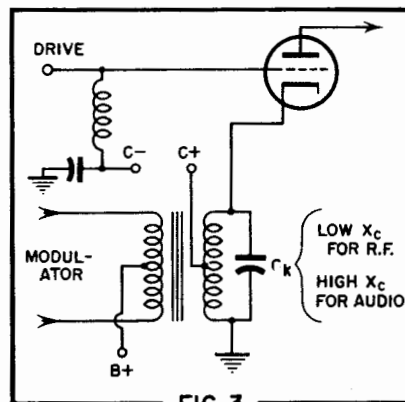

In the example discussed above, the cathode by-pass could have been made large without limit, without detrimental effects on circuit performance. Circuits exist, however, in which there is an upper limit to the capacitance which can be used to by-pass an impedance in the cathode circuit. As an example, consider the cathode-modulated Class C r.f. amplifier shown in Fig. 3. Here the condenser is required to by-pass r.f. around the modulated transformer. Otherwise regeneration may result from feedback into the grid bias circuit. However, if the cathode by-pass is made too large, the modulation frequencies will be shunted to ground. A value of capacitance must be chosen which has very low reactance at the

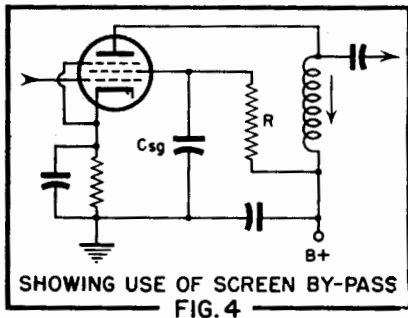

carrier frequency, but a high one at the highest modulation frequency. Fortunately, this is easily done in this case because of the wide difference in the frequencies involved; a .002 microfarad condenser has a reactance of about 8.0 ohms at an r.f. frequency of 10 Mc. but almost 16,000 ohms impedance at 5000 c.p.s. A good mica or ceramic condenser of low inductance would be used in this application.

Of course, not all cathode bias resistors must be by-passed. In many high fidelity audio amplifiers and television i.f. amplifiers controlled amounts of negative feedback are introduced to improve the over-all performance. In such cases, the loss of gain is compensated by adding extra stages. Cathode by-passing is also omitted in Class A push-pull amplifiers, since the a.c. signal components of both tubes flowing in the resistor are out of phase and cancel out.

#### Screen By-Passing

The screen element of tetrode and pentode electron tubes must be effectively by-passed to ground for all signal voltages present. This is necessary to prevent degeneration of a type very similar to that discussed above. For example, consider the television i.f. amplifier stage shown in Fig. 4. Here the screen voltage is derived from the plate supply through a dropping resistor. If the a.c. signal component is allowed to pass through the screen dropping resistor, the gain of the stage will be reduced. For this reason, a by-pass condenser is used to ground the screen for signal voltage without interfering with the

application of the d.c. screen voltage. If the screen by-passing is imperfect at any frequency, the response of the amplifier will fall off there or it may oscillate. It is common practice to make the screen by-pass reactance small compared with the cathode-to-screen impedance. This is obtained by dividing the screen voltage by the screen current.

Mica or ceramic condensers are used in values ranging from 100 micromicrofarads to .01 microfarads for radio frequencies, while high quality paper units and electrolytics are used for audio screen by-passing. As in cathode resistor by-passing, certain circuits require screen by-passing sufficiently heavy to ground the screen for r.f. but not for audio frequencies. A typical example of such selective by-passing would be the plate and screen modulated Class C amplifier shown in Fig. 5. In this circuit the screen voltage must vary with the modulation and so should not be by-passed for audio frequencies. A .002 microfarad condenser is sufficient in most cases and does not result in a loss of "highs".

#### Plate Circuit By-Passing

As in the cathode and screen circuits discussed above, any impedance in the plate circuit of a vacuum tube stage is common to another stage, or another part of the same stage, can cause feedback and instability if not properly by-passed. The reasons for this are obvious from Fig. 6a. Here the plate voltage for two stages of an i.f. amplifier are taken from the same power supply and no decoupling is employed. The internal impedance of the power supply is represented by  $R_s$ . Since the plate signal current is allowed to flow through  $R_s$ , a voltage drop is developed across it which is introduced into the plate circuit of the preceding stage via the plate lead. This signal voltage is then fed to the grid circuit of the second stage, with the result that oscillation will occur if the stage gain is high enough.

Instability due to plate circuit feedback is prevented by the use of de-

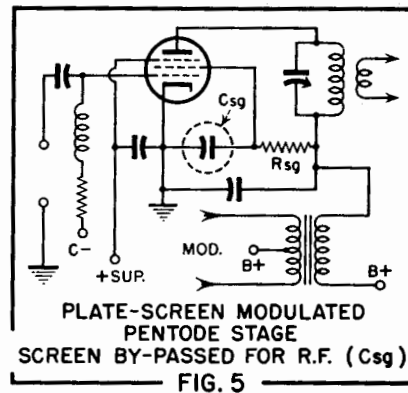

coupling filters consisting of series isolating resistors and by-pass condensers, as shown in Fig. 6b. Such decoupling networks are most easily understood if thought of as voltage dividers at the feedback signal frequency. For example, in Fig. 6b assume that the internal impedance of the power supply ( $R_s$ ) is imperfectly by-passed by  $C_1$  at the signal frequency. A small signal voltage ( $E_s$ ) is therefore developed across the power supply impedance and travels down the plate lead to the preceding stage. The function of the decoupling filter  $R_d$  and  $C_2$  is to greatly attenuate this signal since they divide it in the ratio of their impedances. Thus, if the reactive impedance of  $C_2$  is only 1 ohm and the resistance of  $R_d$  is 1000 ohms, the feedback signal is divided by that ratio so that only 1/1000th of the voltage developed across the power supply impedance is applied to the preceding stage. Of course, the d.c. plate voltage is unaffected except for a small IR drop across  $R_d$ . In cases where this drop couldn't be tolerated, an inductance could be used in place of  $R_d$ . Several such RC or LC decoupling filters are sometimes used in series in cases where feedback is particularly troublesome.

#### By-Passing Precautions

By-Pass wiring in some circuitry, including high gain amplifiers and VHF circuits, must be done with extreme care to avoid common impedances which introduce feedback. The

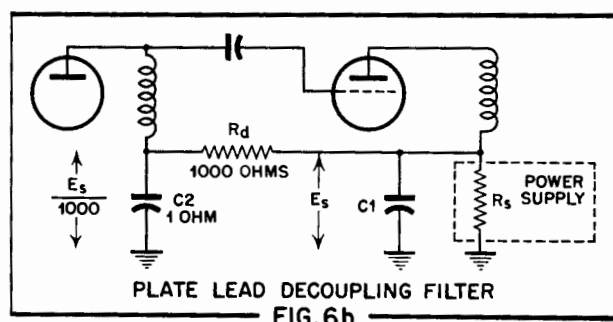
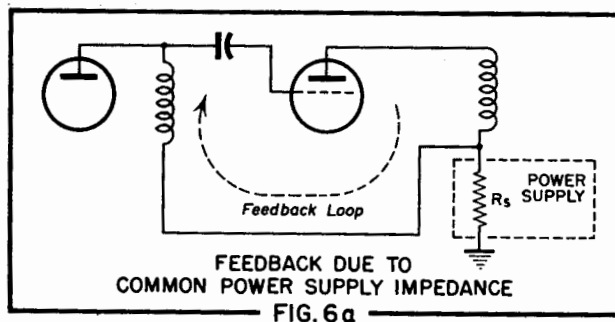

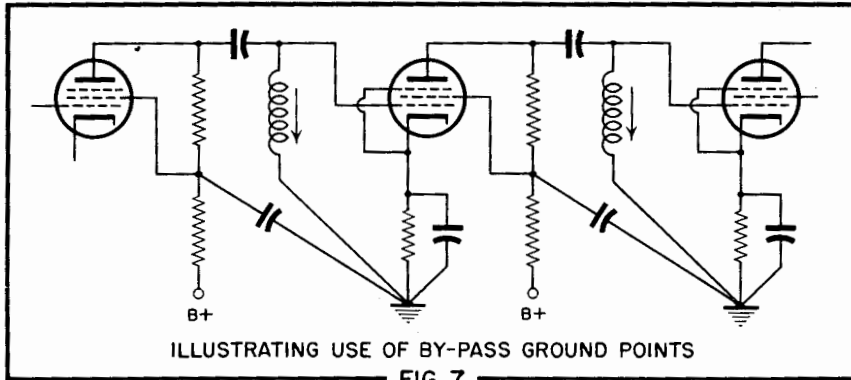

ILLUSTRATING USE OF BY-PASS GROUND POINTS

FIG. 7

safest rule for by-passing multi-stage amplifiers is to ground all by-passes associated with the output of one stage and the input of the next stage to a single ground point, as in Fig. 7.

In applications where very effective by-passing at a single frequency is required, some designers have resorted to the use of *series resonant by-passing*. By this method, the capacitance of the condenser is resonant with the inductance of its wire leads to obtain the theoretically zero

impedance of a series resonant LC circuit.

The self inductance of certain types of windings can be used and capacitors made which will have self resonant characteristics at any frequency. Such capacitors have been used in I.F. by-pass circuits of AM receivers to trap I.F. voltages.

The self-resonance of the capacitor may be found by connecting the ends of the leads together and measuring the frequency at which this L-C combination produces a response on a

grid-dip meter or other absorption indicating device. The exact length of the wire lead to be used in the circuit must be used in this measurement for precise results. This is illustrated by the fact that the resonant frequency of a tubular .01-mfd unit having leads of #20 wire 1/2-inch long is about 11 mc. However, if the leads are trimmed to 1/8-inch, the self-resonance is raised to about 40 mc.

For capacitor types which do not have flexible lead wires, the terminals may be connected by a wire of known or calculated inductance and then correcting for this added inductance to find the true resonance.

*Dual by-passing* is frequently used where effective by-passing must be provided over a wide band of frequencies. A small, low inductance unit for r.f. is connected in parallel with a large condenser of poorer quality for audio frequencies. The high capacitance unit, if used alone, would contain too much residual inductance to be effective for r.f. and economy prevents the use of a mica or other high quality condenser of sufficient capacity to by-pass all frequencies.

## Non-Linear Resistors

A FEW electrical devices are distinguished by their non-linear current-vs-voltage characteristics of a magnitude sufficiently great to affect performance. Often this phenomenon is a characteristic. For example; non-linearity is observed in the plate characteristic of a vacuum tube under certain operating conditions, the extremity of a diode tube response, iron-cored inductors operated in the region of saturation, and in biased capacitors having special ceramic dielectrics (dielectric amplifiers). These are only a few examples. The non-linearity of certain 2-terminal devices such as resistor also may be employed to modify the operating characteristics of some circuits. These latter *non-linear resistors* do not obey the simple relationship  $R = E/I$  of Ohm's Law.

Simple non-linear resistors are used in oscillators, wave shaping networks, voltage regulators, current regulators, constant-output potentiometers and voltage dividers, voltage-selective circuits, amplitude limiters, frequency multipliers, surge suppressors, etc. Their use in electronics is increasing as new requirements for non-linear current-voltage response arise.

The general characteristics of some common 2-terminal non-linear resistors of several classes will be described here. In some instances, as will be seen, these devices have other prime uses and their application as non-linear resistors is secondary. Typical applications will be shown.

### Thyrrite

Thyrrite resistors were introduced by General Electric Company and

were applied in the electric power field some number of years before entering electronics. Thyrrite resistors are made of silicon carbide, bound with a filler, then pressed and fired at high temperature. They are fabricated in the form of pigtailed rods (identical to "radio resistors"), discs, washers, and stacks. Small units suitable for electronic applications are supplied up to 10 watts power rating (continuous).

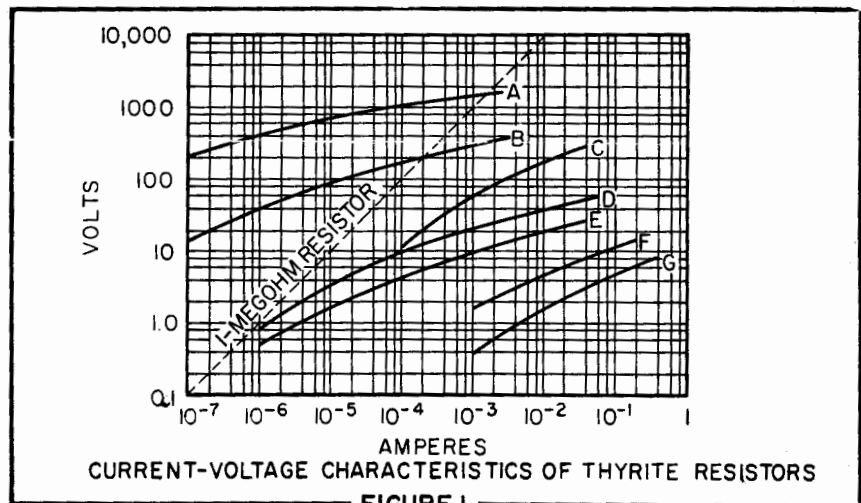

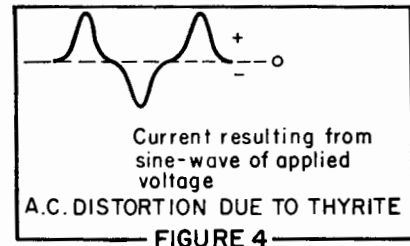
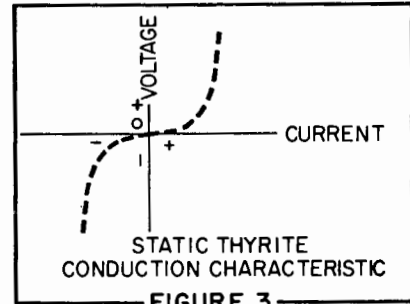
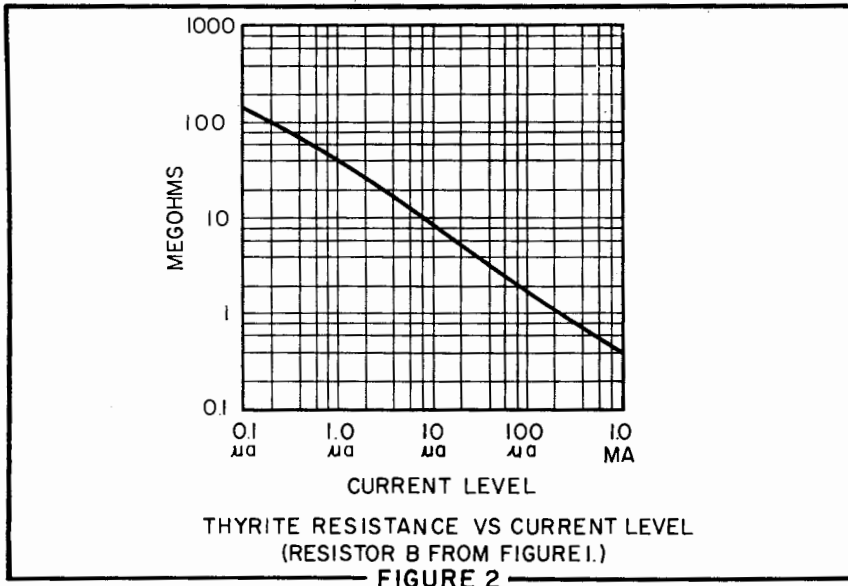

The non-linearity of the Thyrite resistor is expressed by  $I = kE^n$ , where  $I$  is the instantaneous alternating or direct current (amperes),  $E$  the instantaneous applied voltage,  $k$  a constant (amperes at 1 volt), and  $n$  an exponent between 3.5 and 7 governed by the manufacturing process. Figure 1 shows a set of typical Thyrite current-voltage curves for several types of G. E. Thyrite resistors. The curve for a conventional 1-megohm linear resistor is plotted for comparison. From these curves, it may be seen that large current changes result from small applied-voltage changes.

Figure 2 is a plot of resistance vs current for resistor B from Figure 1. Note in Figure 2 that a change

of 10,000 to 1 in current flowing through this resistor changes the resistance of the latter approximately 375:1.

Thyrite resistors have the advantage of operating in both a. c. and d. c. circuits. Any rectification effects are negligible. (Figure 3 shows a typical static positive-negative conduction curve). High-frequency a. c. operation of Thyrite is possible, the limiting factor appearing to be capacitance. It should be noted, however, that in a. c. operation the non-linearity of the Thyrite volt-ampere characteristic causes distortion of the current waveform. Figure 4 shows the distorted current wave accompanying a sine wave of applied voltage. Observe that odd-ordered har-

monics are prevalent. This phenomenon is utilized in simple frequency multipliers and harmonic accentuators.

The temperature coefficient of Thyrite resistance is negative in sign and varies from  $-0.4$  to  $-0.73$  percent per degree Centigrade in the range  $0$  to  $100^\circ\text{C}$ .

Figure 5 shows several typical circuits utilizing the properties of Thyrite resistors.

Figure 5(A) is a simple voltage regulator or compressor for smoothing variations in supply voltage. The fluctuating input voltage produces fluctuating current which flows through the Thyrite resistor (T) and a linear limiting resistor (R) in

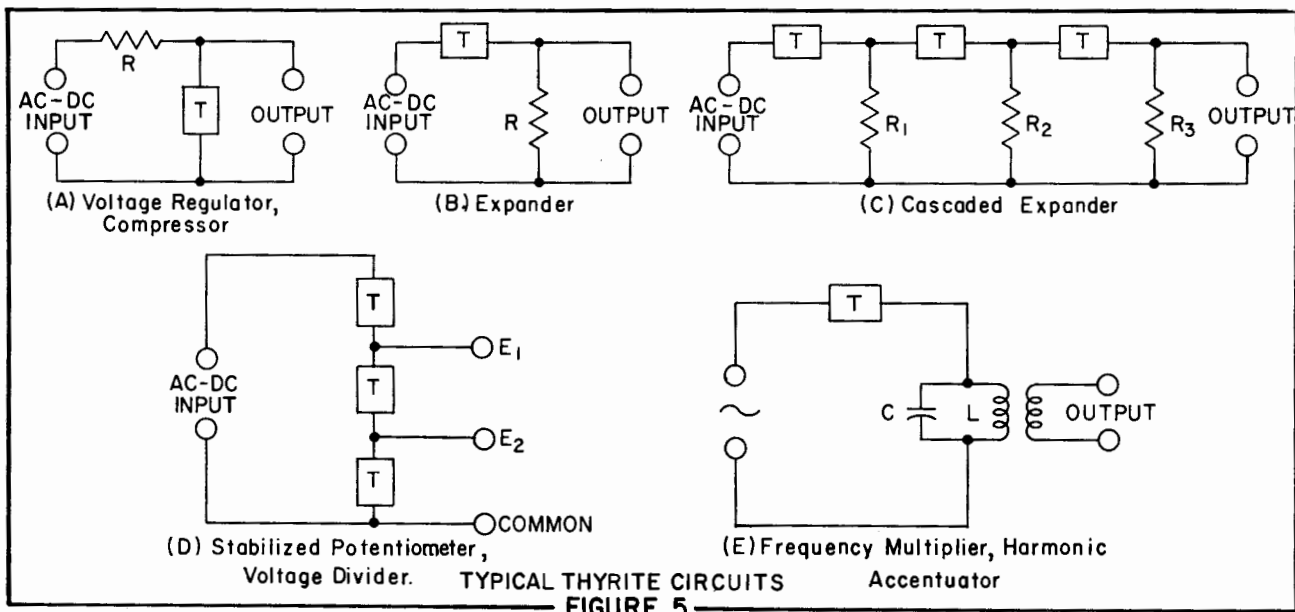
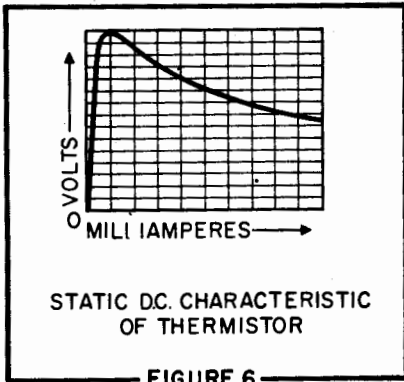

FIGURE 5





series. Fluctuations in the resulting voltage drop across the Thyrite resistor are considerably lower in amplitude than those in the supply voltage, due to the non-linear E/I relationship in the Thyrite. It should be noted that a voltage reduction unavoidably occurs because of potentiometer action between R and T.

In the expander circuit in Figure 5(B), the opposite action is secured. Small fluctuations in applied voltage produce large fluctuations in current through Thyrite resistor T. These current fluctuations in turn produce

a fluctuating output-voltage drop across R. Since the resistance of R must be small with respect to that of T, voltage divider action between the Thyrite and linear resistance legs of the circuit produces a drop in voltage level. Several TR sections may be cascaded, as shown in Figure 5(C), to secure additional expander action, at the expense of course of further voltage division in each section.

Figure 5(D) shows a potentiometer or voltage divider with Thyrite sections. The non-linear E/I characteristic of the Thyrite sections yields a nearly constant output voltage at each tap, although supply and load currents are variable.

For efficient operation of the circuits shown in Figures 5(A) and (D), the Thyrite current must be high with respect to the output load current. In Figures 5(B) and (C), current in resistor R must be high with respect to output load current.

Figure 5(E) shows how a Thyrite resistor can be connected into a circuit to accentuate harmonics and act as a simple frequency multiplier. Alternating current is fed into the circuit and undergoes distortion in passing through the Thyrite. The tuned

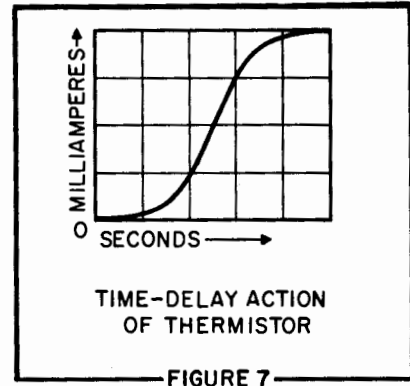

circuit, LC, is adjusted to the desired multiple frequency. It has been shown already in Figure 4 that odd harmonics are favored by this type of operation. The Thyrite frequency multiplier thus is most practical for tripling, quintupling, etc. The Thyrite resistor is a dissipative element, however, and its insertion into a circuit in the manner shown in Figure 5(E) results in some power loss. In applications where a considerable amount of power is available, the relative simplicity of the Thyrite frequency multiplier can offset its unavoidable power absorption.

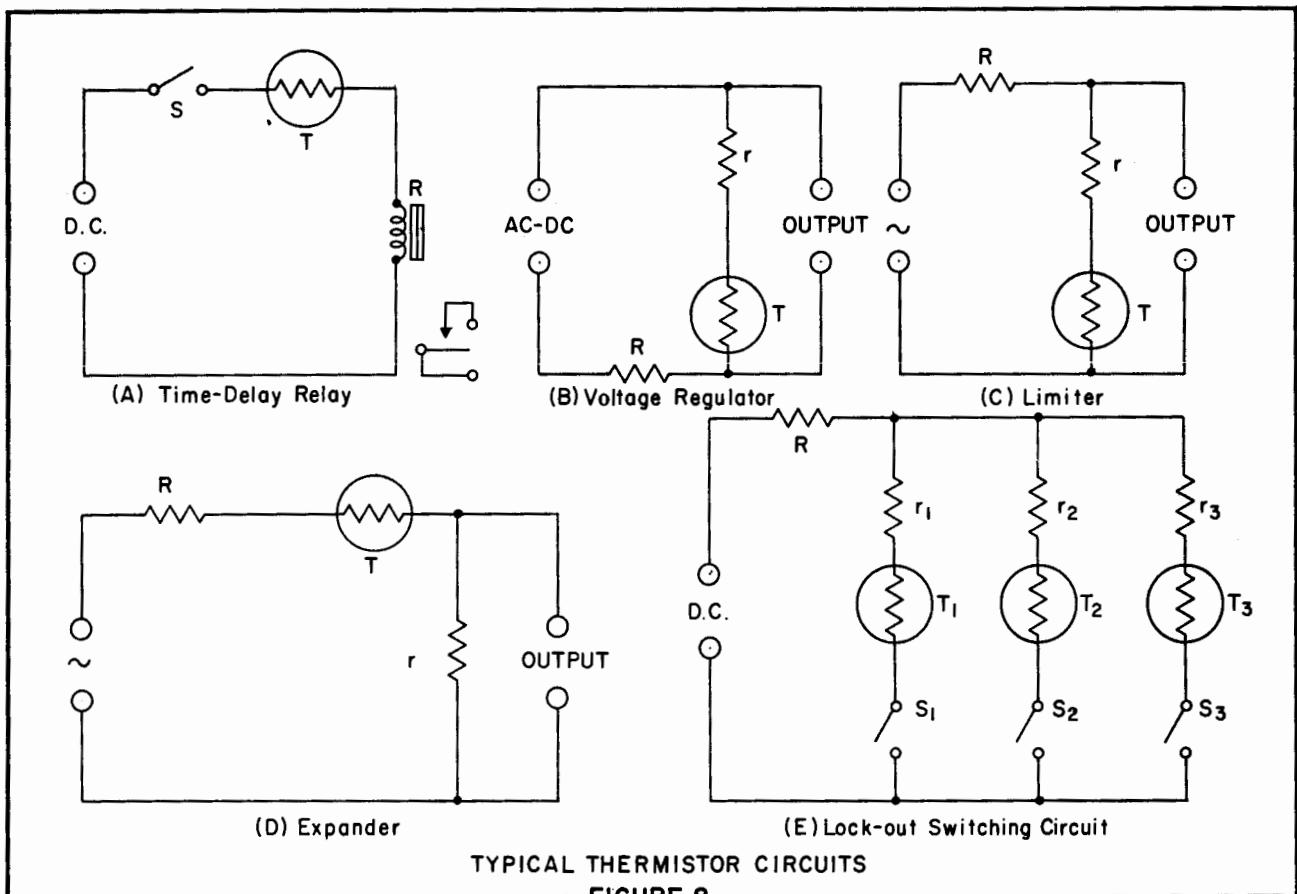

### Thermistors

The thermistor, a product of research by Bell Telephone Laboratories and manufactured by Western Electric Company, is another interesting non-linear resistance device. Its action results from internal heating effects in special materials.

Thermistors basically are thermal-sensitive resistance devices. They are manufactured in the shape of rods, discs, beads, wafers, and flakes and are made of various semiconductor materials. Like Thyrite, the thermistor can be used with either a. c. or d. c.

Figures 6 and 7 show two important response curves describing thermistor action. From Figure 6, it is seen that the voltage drop across the thermistor increases non-linearly and rapidly, with current flow up to a point beyond which the rate of increase falls. Finally, a peak is reached and beyond this latter point, the voltage drop decreases with increasing current, displaying *negative resistance*. An interesting side observation is that this negative-resistance property has been utilized to obtain low-frequency tubeless oscillation and amplification with thermistors.

In Figure 7, the plot shows how at a particular applied voltage internal heating causes the magnitude of thermistor current to vary as a function of time. This property has been utilized in various simple time-delay devices.

Figure 8 shows several simple circuits employing thermistors. In all except Figure 8(A), a small current-limiting resistor,  $r$ , is indicated. Figure 8(A) is a time-delay d. c. relay based upon the action illustrated by the curve in Figure 7. Some seconds after the switch,  $S$ , is closed, the circuit current rises to a value high enough to close the relay. The delay interval depends upon thermistor

characteristics and supply voltage level, and can be adjusted to some extent by means of linear series resistance.

Figure 3(B) is the circuit of a regulator for supply-voltage variations and is somewhat similar to the Thyrite voltage regulator. Its operation is based upon the non-linearity of the thermistor which results in smaller variations in thermistor voltage drop than the fluctuations occurring in supply voltage and current.

Action of the limiter circuit, shown in Figure 8(C), is similar to that of the voltage regulator, amplitude excursions in the input signal being reduced in the output without clipping or slicing action.

Operation of the thermistor expander circuit, Figure 8(D), is the opposite of that of the limiter. The thermistor and load resistor are interchanged in position, output being taken across the resistor. A small signal-voltage change produces a large thermistor current change and a large voltage change across the output resistor.

A voltage division takes place in the circuits shown in Figures 8(B), (C), and (D), as the result of potentiometer action between the thermistor and the linear series resistor. Because of this action, the absolute level of the applied voltage is reduced in the output.

Figure 8(E) shows a lockout-type switching circuit employing thermistors. In each leg of the circuit,  $r$  is a load resistor or represents some device, such as a relay, which is to be actuated by current flowing through the associated thermistor. The supply voltage and the value of linear series resistor  $R$  are chosen such that this resistor will support the current of only one leg before its voltage drop becomes excessive.

When one switch (say,  $S_1$ ) is closed, the associated thermistor "breaks down" allowing current to flow through and operate the associated device,  $r_1$ . This lowers the voltage at the inside of  $R$ , so that no other thermistor can "fire." Only after  $S_1$  is opened, can either of the other circuit legs be operated. Operation of any one thermistor leg thus locks out all of the other legs. An arrangement of this type would enable a number of devices having similar volt-ampere characteristics to be connected across a single voltage pair, but with only one device operable at a time.

### Filamentary Devices

The tungsten-filament incandescent lamp is fairly well known as a non-linear resistor in which current change lags a corresponding change in applied voltage. Up to the point at which heating effects begin to evidence, the filament volt-ampere characteristic is linear, or very nearly so. The non-linear region of lamp-filament resistance has been utilized in voltage-stabilization bridges, simple regulators, and allied devices.

In a common application, the lamp-type resistor is used as an automatic regulator of degeneration voltage in low-distortion, RC-tuned oscillators. A typical circuit is shown in Figure 9.

In Figure 9, the lamp ( $R_2$ ) is the cathode resistor of the first pentode,  $V_1$ . Feedback current from the output of  $V_2$  flows through capacitor  $C$  to the frequency-selective RC network in the grid circuit of  $V_1$ . A portion of this current also flows through resistor  $R_1$  and the lamp,  $R_2$ , establishing a negative feedback voltage across the latter. The lamp resistance is low when the feedback current is small, and is high when this current is large. Thus; strong oscillations result in large amounts of

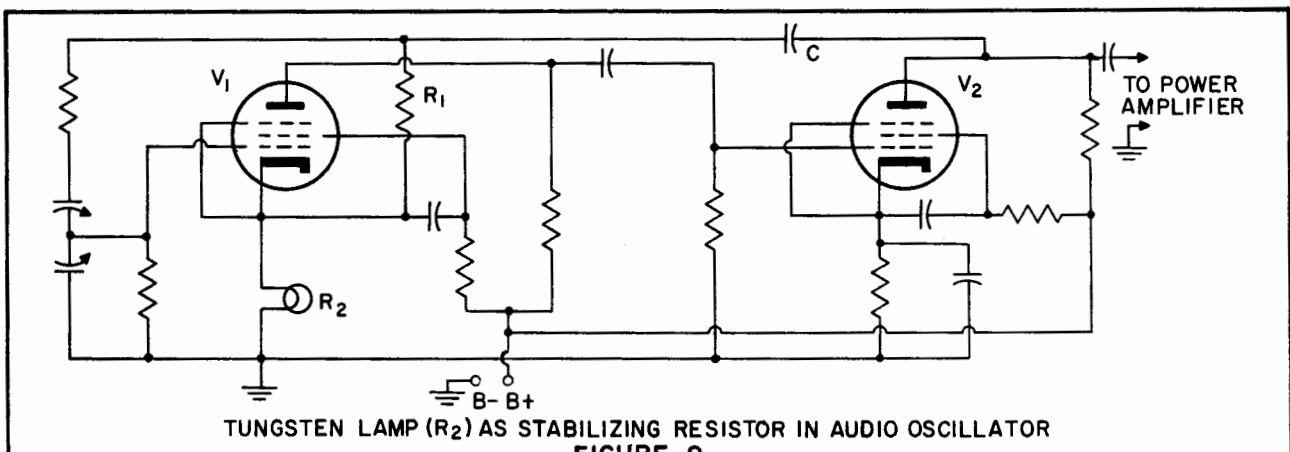

FIGURE 9

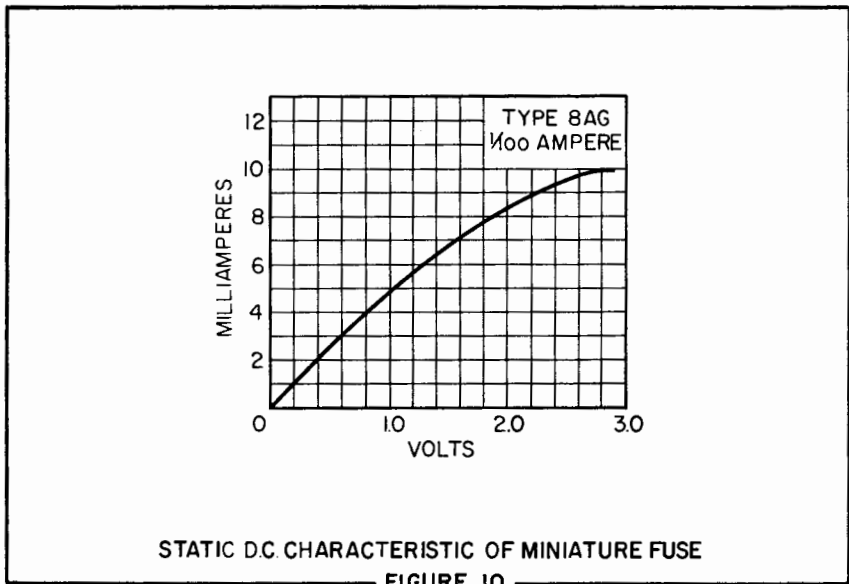

FIGURE 10

inverse feedback voltage across  $R_2$ , and this degeneration in turn reduces the amplitude. The opposite also is true; at weak oscillation amplitudes; there are lesser amounts of degeneration, and gain through the two-tube circuit automatically rises. The net result is uniform amplitude of oscillation.

Thermistors also are used occasionally in some RC-tuned oscillator circuits to stabilize oscillation amplitude.

Small filamentary, low-current fuses exhibit a type of non-linearity

somewhat similar to that of the tungsten filament. Figure 10 shows the static d. c. volt-ampere characteristic of a sample Type 8AG 10-milliamperere Littelfuse. In this instance, response is linear from zero up to the 0.8 v., 4 ma. point. Beyond this, the non-linearity is apparent.

When d. c. -biased to a point within the square-law region of their non-linearity, such fuses often are used as bolometer-type detectors in microwave work. This provides an extremely simple and inexpensive demodulator at frequencies up to many hundreds of megacycles.

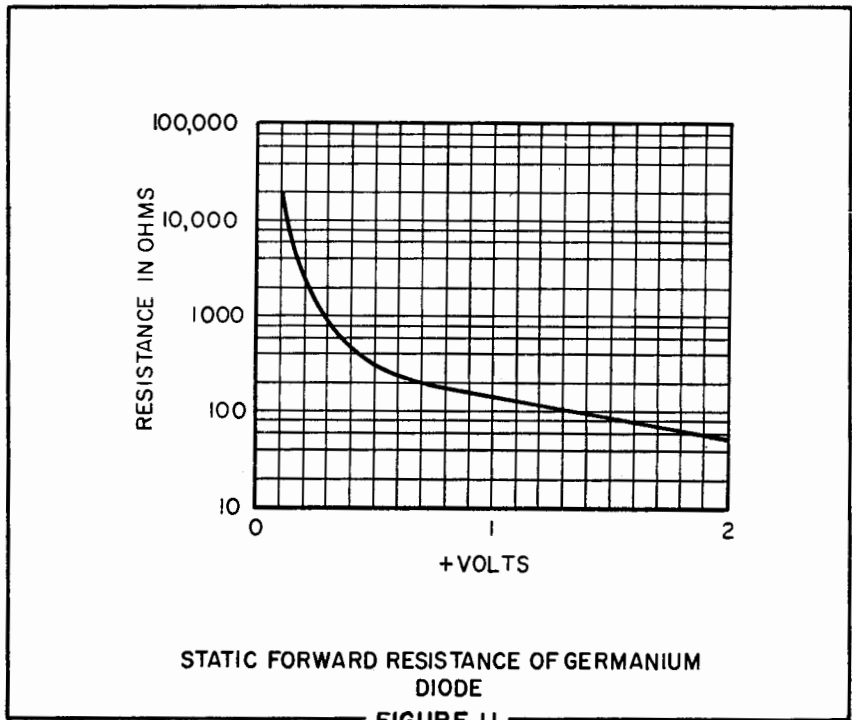

FIGURE 11

### Diode-Type Resistor

Non-linearity in the forward conduction characteristic of the germanium diode suits this simple component to use as a non-linear resistor in applications within its current capabilities. While the reverse-conduction (back-current) characteristic of the diode also is non-linear, it does not in general offer the same possibilities of application that are available with the front conduction.

Figure 11 shows a plot of forward resistance vs applied voltage for a high-conduction-type germanium diode. Here, the polarity of the applied voltage is such that the anode of the diode is positive. Diodes may be connected in series, parallel, series-parallel, and parallel-series to obtain many attractive non-linear resistance effects.

Various portions of the forward volt-ampere characteristic of the germanium diode exhibit square law, logarithmic, and finally approximately linear relationships between  $E$  and  $I$ . By operating the diode in a desired one of these regions, the particular corresponding portion of the curve can be utilized to correct or modify the  $E/I$  characteristic of another circuit. For example, a linear microammeter may be converted into a square-law instrument by using the forward resistance of the diode as the meter series resistance (multiplier).

Diodes suffer somewhat in comparison with other 2-terminal non-linear resistors because the diode is a rectifier. This limits application in some cases to direct-current use only. However, small a. c. signals may be superimposed upon a d. c. forward bias current applied to the diode, the two currents being so proportioned that the net diode voltage never becomes zero or negative. Diodes also are relatively low current devices, as compared with some other non-linear resistors.

Like the Thyrite resistor, the forward-conducting diode is capable of distorting an a. c. current waveform and occasionally is used to accentuate harmonics. The requirement is that the diode current magnitude be such as to operate the diode in its most non-linear region. Thus, the simple series connection of a diode in the plate or grid lead of an oscillator or amplifier can accentuate harmonic content of the current waveform when this type of operation is required. An example, is the distortion of waveform of a standard-frequency oscillator to produce high-order harmonics for calibration purposes.

# Amateur Applications of Crystal Diodes

The extensive development in electronics during World War II saw the return to active service of many circuits and devices which had previously been considered obsolete. Such things as the superregenerative detector, the magnetron oscillator, and the rotary spark gap were "resurrected", subjected to further development, and ultimately found important applications in military radio and radar equipment.

Not the least important among these "rediscovered" devices is the crystal detector. For, although the silicon, galena, or iron pyrites crystal, with its ever-present "catwhisker", was a household item during the early days of broadcast radio, it was ultimately replaced by the vacuum tube. Then, when transit time and noise limitations ruled out the vacuum tube as a detector or mixer for microwave radar, the crystal detector was again resorted to.

As a result of this war-time rejuvenation, the clumsy crystal detector of old has emerged as the remarkably dependable, efficient, and compact unit known as the "semiconductor diode". These units are finding extensive usage in many types of circuitry. The amateur radio operator and experimenter has been especially quick to adapt the versatile, economical crystal to an ever-widening variety of uses. We will discuss here some of the more recent uses for crystal diodes in amateur practice, and present information on recommended types for specific applications.

## Constructional Features

The present popularity of the crystal diode is due to the fact that its modernized construction makes it a practical circuit element which is capable of outperforming the vacuum tube in many instances. The elimination of the vexing process of searching for a "hot-spot" with a movable catwhisker by the use of a fixed rectifying contact makes it possible to package the crystal in a very compact capsule. This unit is also quite rugged and moisture-proof, since the capsule containing the diode elements is impregnated with a wax filler.

The general construction of a point-contact rectifier is illustrated in Fig. 1. The essential elements are the small "wafer" of a specially processed semiconductive material, a fine tung-

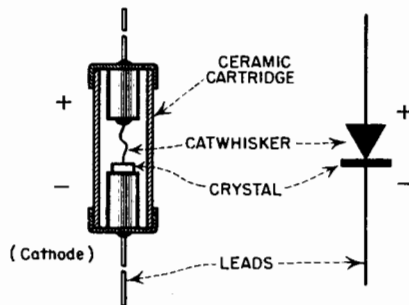

CRYSTAL RECTIFIER  
AND STANDARD SYMBOL  
FIG. 1

sten-wire catwhisker which is sharply pointed at the end in contact with the semiconductor, and an insulating body or capsule which holds these two parts in rigid contact and provides external electrical connections to them. There are several constructional variations, each intended for a specific type of application. Some crystal diodes for r. f. applications are designed for insertion into a "socket" consisting of spring contact fingers, while others intended primarily for low-frequency and video work, are equipped with pig-tail leads and have the general appearance of small resistors or tubular capacitors. More recently, units which are hermetically sealed in glass envelopes have become available.

## Electrical Advantages

In addition to the mechanical advantages of small size and ruggedness enumerated above, the point-contact rectifier has several important electri-

cal attributes which make it preferable to vacuum tube rectifiers for many uses. Of course, one obvious advantage is the elimination of filament power consumption. This adds to the overall efficiency and makes it easy to use the crystal rectifier where the circuit must have low capacity to ground.

At extremely high radio frequencies, the two electrical characteristics which are most responsible for the usefulness of the crystal diode are the low inter-electrode capacitance and the short transit time. Since the sharpened point of the tungsten wire makes contact with the semiconductor over a very small area, the capacitance of modern crystal rectifiers may be less than one micromicrofarad. Transit time is negligible in most crystals because the rectifying "barrier layer" through which electrons must flow between the semiconductor and the metal contact may be only one millionth of a centimeter in thickness—much closer than it is possible to space the electrodes of a vacuum tube. For these reasons, the crystal has been used to detect r. f. energy well into the millimeter wave region.

## Crystal Types

Crystal diodes may be divided into two major categories; the high sensitivity types for high frequency detector and mixer applications, and the high-back-voltage variety which serve as general purpose rectifiers and second detectors. The high sensitivity kind are usually silicon crystals, while the high-back-voltage types use a germanium semiconductor.

TABLE I			
		CRYSTAL TYPES	
NO.	USE	UPPER FREQ. (Mc.)	REMARKS
1N21A	Mixer (S)	3000	
1N21B	"	"	Improved 1N21A
1N21C	"	"	Most Sensitive
1N22	Inst. Rect. (S)	"	
1N23	Mixer (S)	10,000	
1N23A	"	"	Improved 1N23
1N23B	"	"	Most Sensitive
1N25	"	1000	High Burnout
1N26	"	24,000	
1N27	Video (S)	3000	
1N28	Mixer (S)	"	High Burnout
1N29	Video (S)	"	
1N30	"	10,000	
1N31	"	"	
1N32	"	3000	High Sensitivity
1N33	"	"	High Burnout
1N34	High-Back-Volt (G)	100	Gen. Purpose
1N35	"	"	Matched Pair 1N34's
1N36-1N70	"	"	2nd. Detectors, D.C. Restorers, etc.

(S) Denotes silicon crystal

(G) Denotes germanium crystal

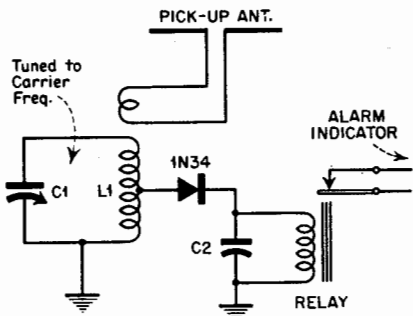

CARRIER FAILURE ALARM  
FIG. 2

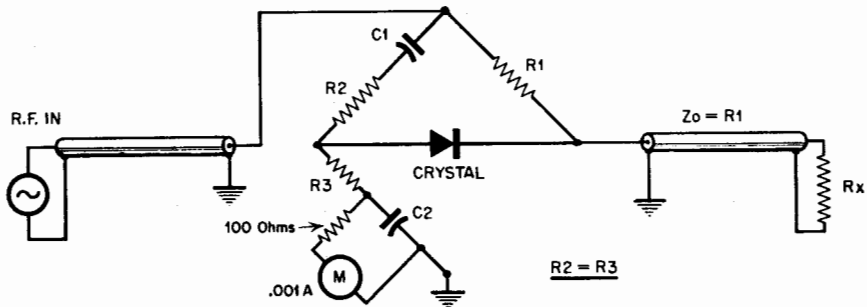

CRYSTAL STANDING-WAVE INDICATOR  
FIG. 3

Table 1 lists some of the various types which are, or have been commercially available, and gives the recommended use and upper frequency limit. As a general rule, crystal rectifiers can be used with good rectification efficiency and performance at any frequency below this limit.

To date, the high-back-voltage family of crystal diodes has enjoyed the greatest popularity in amateur radio applications. This is due to the fact that a greater variety of low frequency uses for crystals as vacuum tube substitutes have been found. The 1N34 germanium diode, in particular, is used in dozens of circuit applications where a vacuum-tube diode such as the 6H6 or the 6AL5 would otherwise be employed. The high-back-voltage types are usually limited to frequencies below 100 mc. because the rectification efficiency of germanium falls off above this frequency.

With the growing use of the microwave amateur bands, it is expected that the silicon diode will be used to a much greater extent in amateur gear. At frequencies above the 420 mc. band the crystal mixer has decided advantages over vacuum tubes from noise considerations. Crystal mixers have been produced which have noise figures approaching the theoretical optimum—the noise which would be produced in an equivalent resistor. Of course, since the crystal contributes no signal gain, the first i. f. stage succeeding it must also have

a good noise figure. The low-noise cascode amplifier is ideal for this purpose.

#### Applications of Germanium Crystals

Most of the uses of germanium diodes in amateur work to date have been as meter rectifiers in r.f. detecting devices such as the TVI harmonic checker for locating spurious transmitter radiations which was described in Section I under Television Interference Filters. Detecting instruments of this kind, when tightly coupled and used with a microammeter, will indicate r.f. energy of only a few microwatts.

Other indicating devices which have basic circuits very similar to the harmonic checker are the crystal field-strength meter, the absorption wave-meter, and the modulation monitor. An interesting variation of this circuit is the carrier failure alarm shown in Fig. 2. It may be employed to indicate the presence of r. f. power at the antenna of 'phone transmitters and so prevent "lost" transmissions due to the failure of the antenna change-over relay, transmission line, or other components. The alarm relay used must be of a sensitive type which will pull up at about one milliampere. The alarm indicator may be a signal light or a buzzer.

Another family of circuits which commonly use germanium diodes are the directional coupler type of stand-

ing-wave indicators and power monitors. Fig. 3 is the schematic of a typical resistance bridge standing-wave indicator which illustrates the principle of these very useful instruments. This simple circuit can be used to measure the standing wave ratio existing on a transmission line and thus determine the impedance of the antenna or other terminating device at its end. It consists of a resistance bridge which is balanced when the cable terminating resistance ( $R_x$ ) is equal to  $R_1$ . Under this condition, no current flows through the germanium crystal and the meter reading will be zero. If, however, the load resistance does not equal  $R_1$ , the bridge is unbalanced and a current which is proportional to the degree of impedance mismatch flows through the crystal and is indicated on the meter. The value of  $R_1$  must be equal to the surge impedance of the transmission line with which the bridge is to be used. Calibration may be accomplished by connecting various non-inductive resistors of known value greater than  $R_1$  across the output transmission line and noting the meter deflection. The voltage standing-wave ratio is then equal to  $R_x/R_1$ . A graph of VSWR versus meter reading may be plotted, or a special scale on the meter may be marked directly in VSWR. Before readings are taken, the meter deflection is adjusted to full scale by open-circuiting the

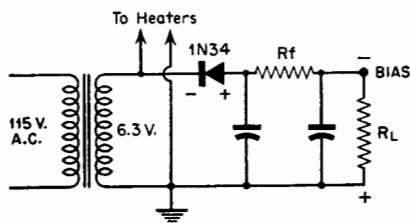

BIAS SUPPLY  
FIG. 4

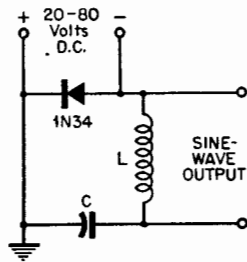

SINE-WAVE  
OSCILLATOR

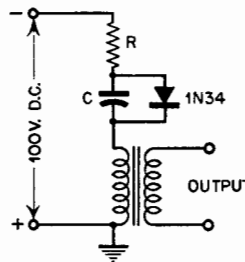

RELAXATION  
OSCILLATOR  
FIG. 5

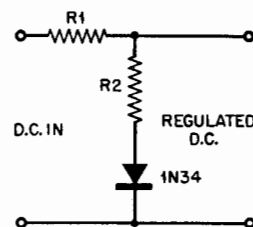

VOLTAGE  
REGULATOR

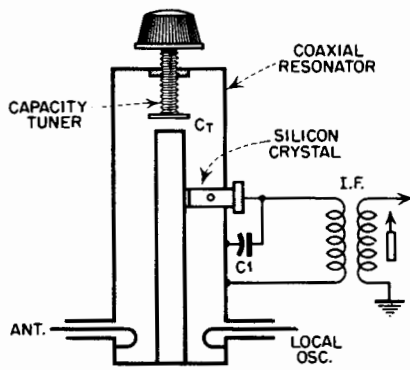

U.H.F. CRYSTAL MIXER  
FIG. 6

terminals to Rx and varying the r. f. input. This variety of standing-wave indicator must be used at low input levels—preferably only a few watts. Other varieties, using other bridge configurations, are capable of handling greater powers.

The germanium diode may also be used to provide a cheap and convenient source of low bias voltage. Fig. 4 shows a bias supply in which the a. c. heater voltage in the receiver or transmitter is rectified by the crystal diode and filtered by an RC filter. The output voltage may be adjusted

by varying the filter resistance. Other rectifier circuits, such as full-wave and bridge connections<sup>4</sup> may be used.

Still another type of application for the germanium diode family makes use of the negative resistance portion of the blocking voltage curve. This unique characteristic, which occurs when a negative voltage on the cat-whisker is allowed to exceed the peak "blocking" voltage, has enabled the 1N34 and other high-back-voltage types to function as sine-wave oscillators and voltage regulators. Fig. 5 depicts basic circuits for these uses.

#### Uses of Silicon Crystals

For frequencies above 100 mc. a silicon crystal should be used in r. f. rectifying devices such as the harmonic checker, field-strength meter, carrier failure alarm, and standing-wave indicator discussed above. The 1N22 is an instrument rectifier which is well suited to such applications.

The silicon crystal diode is also employed in other high frequency circuits where high sensitivity is required. The circuit of a typical h. f. superheterodyne crystal mixer is shown in Fig. 6. The bypass condenser (C1) must have a low value of reactance at the carrier frequency but a high value at the i. f. frequency. Tuning is done by varying the capacitance between the inner and outer conductors of the coaxial circuit.

#### Care of Crystal Rectifiers

In using crystal rectifiers of any type it is necessary to observe certain precautions to prevent damage to the unit. At no time should the rectified current be allowed to exceed the rated maximum value for that type. Otherwise, "burn-out" will occur and the unit will become useless. Although some will withstand instantaneous surges of current of many times the rated average value, it is good practice to prevent such conditions where possible.

Crystal elements must also be protected from high temperatures. When soldering a unit with pig-tail leads into a circuit, excessive heating may be prevented by grasping the part of the lead between the crystal and the connection being soldered with a pair of long-nose pliers.

A suitable test to determine the general condition of a crystal rectifier may be made with a high resistance ohmmeter, care being taken to avoid subjecting the crystal to excessive currents. The d. c. resistance of the unit is measured both ways by reversing the meter leads and noting the resistance in each direction. The "figure-of-merit" is the ratio of these "forward" and "back" resistances. A good unit should have a "front-to-back" ratio of at least 10:1 for silicon crystals and much higher (100:1) for germanium.

## Proper Electronic Wiring Techniques

THE old adage that warns that "a chain is no stronger than its weakest link" is nowhere truer than in the art of electronic wiring. Especially in today's advanced circuitry, where ruggedization and reliability are the keynotes, proper wiring is a prerequisite. Where the destination of a guided missile, the proper functioning of an airport blind landing radar equipment, or the final answer of an electronic computer may depend upon any one of thousands of tiny soldered connections, meticulous attention must be paid to such small details. Even in the research and development field, it is impossible to estimate how many important experiments may have failed because trivial circuit troubles masked the desired results. And in less glamorous applications, such as the telephone industry and the radio and television manufacturing and servic-

ing fields, the extra effort expended in producing dependable wiring has been found to pay dividends. For these reasons, a working knowledge of the proper methods of producing a neat, dependable wiring job are required of every technician and engineer in the field of electronics.

The basic steps in wiring an electronic device are essentially the same regardless of whether the unit is an entire telephone central office or an a.c./d.c. midget radio chassis. They are:

- (a) Mounting the circuit components.
- (b) Wiring and cabling.
- (c) Connecting and lead dress.
- (d) Visual inspection.
- (e) Electrical inspection.

We will discuss here these wiring operations in some detail, with special emphasis on (b) and (c).

#### Mounting Circuit Components

Here it is assumed that the circuit lay-out has been engineered so that the components are located in the unit in positions which give short lead lengths for critical circuits, minimize the effects of hum fields radiated by chokes and transformers, and places temperature sensitive components in the most desirable environmental locations. This lay-out is usually arrived at by using a "mock-up" of the unit and parts and moving the parts around until a suitable arrangement is found. The lay-out engineering should also provide for the use of the components which have the most suitable terminal arrangements for that particular job.

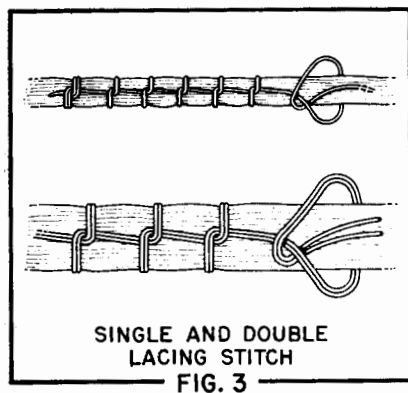
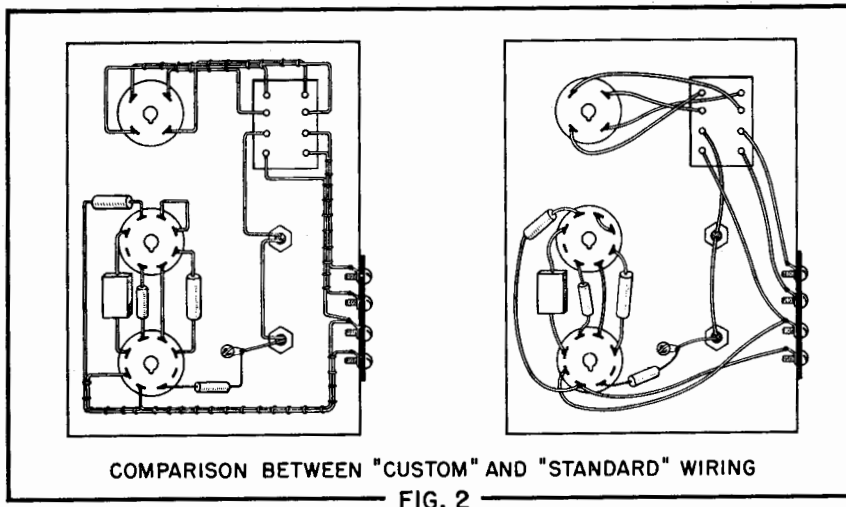
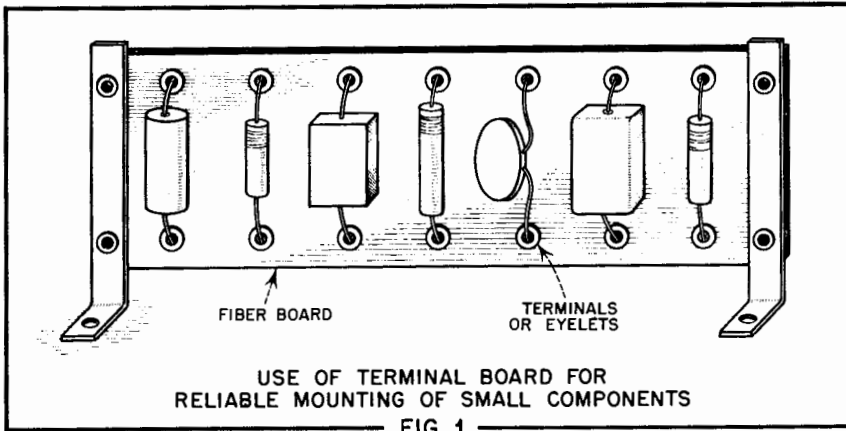

When all parts have been located, the chassis holes required to mount them are drilled or punched. For reliability, all parts except small capacitors, r.f. chokes, and resistors which are light enough to be self-supported on their wire leads must be securely fastened to the chassis. Strip-type terminal boards of the kind illustrated in Fig. 1 are useful for mounting such small components. All other components must be securely attached to the chassis. Where

wires must go through metal panels or chassis, the holes should be suitably insulated. Rubber *grommets* are used for low voltage leads and ceramic *feed-thru* insulators are employed for high voltage circuits. These precautions improve the reliability of the circuit by providing additional electrical insulation and prevent the rough edges of the hole from chafing the wire insulation.

#### Wiring and Cabling

When all circuit components are mounted, the unit is ready for wiring. If the unit is a one-of-a-kind wiring job, the wires may be run individually from one terminal to another, working from the wiring diagram. The routing of the wires depends upon the nature of the circuit, the permanence of the wiring, and the allowable cost of the job. In low-cost production wiring, such as is found in broadcast receivers and television sets, direct point-to-point wiring is employed, without much regard to appearance. In "custom" wired units, such as commercial communication equipment, telephone central office

equipment, and quality audio equipment, all wiring and component parts are kept parallel to the sides of the chassis, so that the finished job presents a neat, "right-angled" appearance. Where groups of wires take the same path, they are "cabled" or "laced" together with waxed cord. The comparison between a chassis wired in this manner and one in which point-to-point wiring is employed, is shown in Fig. 2.

The proper use of the techniques of lacing wire forms is a sure mark of the skilled wiring technician. The lacing stitch illustrated in Fig. 3 is standard throughout the Bell System and is simple and efficient. Note that the parts of the lacing cord which run parallel to the wires emerge from *under* the part that encircles the wires. This stitch is self-locking and will remain tight even when the stitches on either side of it are cut. Wire forms which run from one chassis to another in a relay rack, as well as within-the-chassis wiring, present a much neater appearance and are stronger and more dependable if laced together in this manner to form a compact cable. Lacing also provides an index to the proper location of wires on a terminal strip or other circuit component by "breaking-out" each wire at its proper location with a separate stitch, as illustrated in Fig. 4. This allows the wires to be disconnected at any future time and subsequently returned to the proper terminals.

If more than one unit of a kind is to be wired with cabled wires, or if an especially neat job is desired, the production technique of using a "forming board" is employed. This consists of a large wooden board (Fig. 5) on which pegs or nails are laid out to represent the shape the laced wire form must take. Holes may also be drilled through the board at the location of each terminal to which the wires must be connected. The location of bends and terminals on the forming board are determined by carefully measuring the corresponding distances between the components in the chassis or between chassis. Then the individual wires are run between the proper points on the board as indicated by the wiring diagram. Unskilled labor can perform complex wiring in this manner with few mistakes, since the forming board can be clearly marked with numbers or color coding to indicate the proper points of attachment for each wire as well as its proper routing and sequence in the wiring operation. The end of each wire is anchored on the board by wrapping it

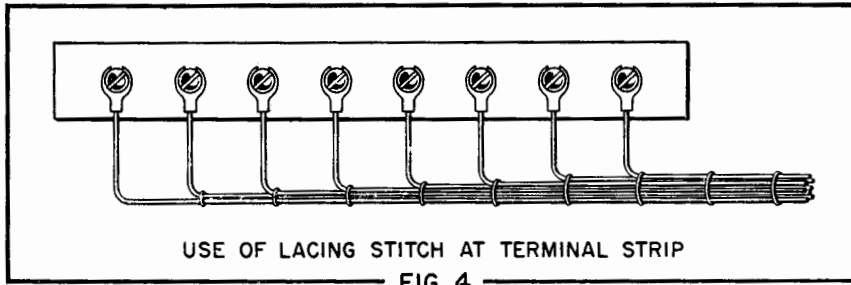

USE OF LACING STITCH AT TERMINAL STRIP

FIG. 4

around a nail or peg placed in a position representing the location of the terminal it will ultimately be connected to. Enough excess should be allowed to permit stripping the insulation to the proper length. If holes are used in the board to "fan" the wires through at the desired locations, the points of attachment will be on the back side of the forming board.

When all of the wires have been run on the forming board, they are cabled together while still on the board. Here they are usually more accessible than in the chassis, making for a faster and neater job. The wires may also be stripped of their insulation and readied for connecting after the cabling is complete so that they are held firmly in the positions they will assume in the chassis.

#### Connecting and Lead Dress

Connecting is the operation of electrically attaching the wires to the component terminals. The type of connection employed depends on the kind of terminals provided on the

circuit components. These may be binding screws, soldering lugs, or directly soldered connections. Soldering in some form is employed in all of these methods but in none of them should the strength of the joint depend upon the strength of the solder. A firm mechanical attachment must be made between the wire and the terminal which is independent of the solder.

In the binding screw type of connection where soldering lugs are not used, the wire should be "tinned" with solder and then formed into a clockwise loop around the screw, so that it will tighten as the screw is tightened. If soldering lugs are used, the grippers on the lug are crimped around the insulation on the wire for mechanical strength and the bared tip of the wire is soldered to the lug. For directly soldered connections, the well-cleaned wire is wound once around the pre-tinned terminal for strength before soldering. Winding the wire around the terminal more than once usually makes subsequent removal of the connection difficult.

The main secrets of producing good soldered connections are the preparation of the joint to be soldered and the maintenance of the soldering iron. Of course, the materials used play an important part also. Tinned wire of the "push-back" variety should be used where possible for ease of "skinning" and connecting. The solder for all radio wiring should have a rosin flux in the core and be a high tin content alloy.

If enameled wire is used, the insulation must be stripped back and the enamel scraped off to expose the bare metal. Otherwise, a dependable soldered joint cannot be made. The methods used to strip the insulation from hook-up wire depend upon the kind used. Most types are conveniently stripped by crushing the insulation with long nose pliers and dressing the frayed ends with the diagonals. For the tougher types of insulation, such as the cellulose acetate braided kinds, a stripping tool is re-

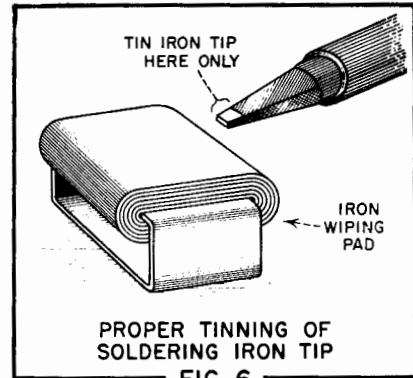

PROPER TINNING OF SOLDERING IRON TIP

FIG. 6

quired. Care must be exercised to prevent "nicking" the wire during stripping and cleaning, as this frequently results in a broken connection later. As mentioned above, when the wiring is done by running the wires between holes in a forming board, the wires can all be skinned at one time by reversing the board and removing the insulation to the right length.

To produce a clean, dependable soldered connection, the soldering iron must be of a type well adapted to the job and carefully maintained. A versatile type of soldering iron tip for general connecting is shown in Fig. 6. The tip should be dressed frequently with a file and tinned while still bright only on the surface indicated in the drawing. The remaining parts of the tip should be allowed to oxidize. An iron tinned in this manner can be used in close places where it is necessary for it to touch other connections without flowing them since the oxide acts as a heat insulator.

The tinned portion of the soldering iron tip should be wiped on a canvas or leather pad attached to the soldering iron stand before each use. This removes excess solder and "slag" and delays erosion of the tip. This operation greatly improves the quality of the job.

In the actual mechanics of soldering a connection, the professional wireman does not apply the solder to the iron and transfer it to the joint being soldered. Little flux reaches a joint soldered in this manner. Instead, the well cleaned iron is applied to the junction of the wire and terminal until both have been heated to near the soldering temperature. Then the solder is applied between the iron and the connection until it flows freely around the junction. A rotary motion of the wrist which "rocks" the iron tip on the joint will serve to work the solder into the joint. The finished connection should be round-

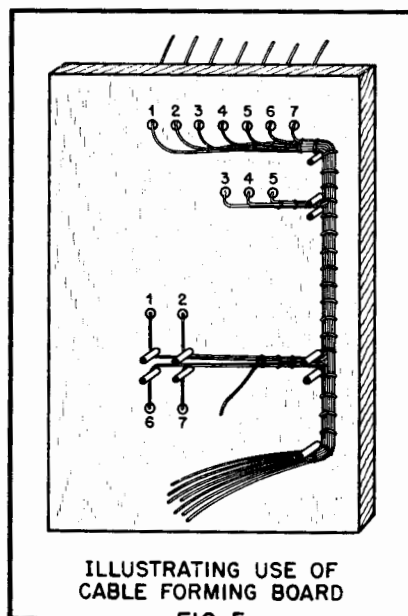

ILLUSTRATING USE OF CABLE FORMING BOARD

FIG. 5



ed and smooth and the solder should have a bright, shiny appearance. If the joint is disturbed before the molten solder has solidified, the solder will look dull and "sugary" and must be melted again.

After the wires have been connected, the leads are dressed to improve the appearance of the wiring job. The insulation on each wire is pushed up against the terminal so that no exposed wire is visible. A small amount of slack is left in each wire to facili-

tate future reconnecting and to remove tension from the soldered joint.

#### *Visual and Electrical Inspection*

Before a newly wired circuit is placed in actual operation, it should be subjected to both a visual and electrical inspection so that any wiring errors can be eliminated before the application of operating voltages causes damage to circuit components.

The first inspection should consist of a thorough visual examination of

the wiring to detect shorts caused by blobs of solder or loose wire ends between terminals, poorly soldered joints, broken wires or terminals, etc. When such defects have been rectified, the circuit should be given an electrical continuity test with an ohmmeter or lamp or buzzer tester. Short circuits between wires and to ground should be tested for as well as electrical continuity between points indicated as common on the circuit diagram.

# SECTION IV

## WAVE FORMS AND WAVE SHAPING

### Non-Sinusoidal Wave Forms

#### Part 1, Passive Wave-Shaping Circuits

**T**HE recent rapid advance of such developments as radar, all-electronic television, pulse modulation systems, electronic navigational aids, computers, and other electronic devices has focussed attention to an ever-increasing extent upon the "care and feeding" of non-sinusoidal electrical impulses of special shapes. As used in modern terminology, a non-sinusoidal voltage or current may be described as one whose variation with time does not satisfy the equation:

$$(1) \quad E_t = E_{\max} \sin \omega t$$

This admittedly "back-handed" way of defining what a non-sinusoidal impulse *isn't* is perhaps simpler and more concise than a lengthy definition of what one *is*. Fig. 1 depicts graphically several of the more common types of voltage waveforms which may be encountered in modern timing circuits. A more or less general discussion of the generation, shaping, amplification, and use of some of these waveforms, using techniques available to the circuit engineer, will comprise the bulk of this discussion. Part 1 of this discussion is confined to the passive circuits which may be used to form non-sinusoidal waves, while the succeeding part will treat self-sustaining generators and other wave forming circuits which employ non-linear elements such as vacuum tubes.

Perhaps the simplest types of waveform shapers, or "pulse shapers" as they are called, are the circuits composed of various combinations of the passive, linear network elements, namely; resistors, capacitors, and inductors. Consider first for example the circuit of Fig. 2, in which are shown a hypothetical signal generator capable of producing any of the wave-

forms of Fig. 1, a pulse shaper in which AA and BB denote terminals to which may be connected any of the passive circuit elements so that various network configurations may be studied, and an oscilloscope for viewing the output voltage of the pulse shaper. The series combination of resistance and capacitance shown connected to the terminals in this case is usually termed an "R-C differentiator" or "pulse sharpener," since the output voltage measured across the

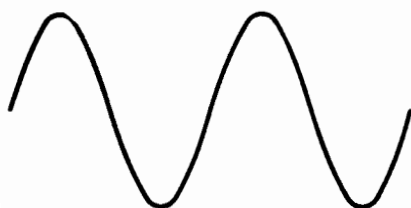

(a) SINE WAVE

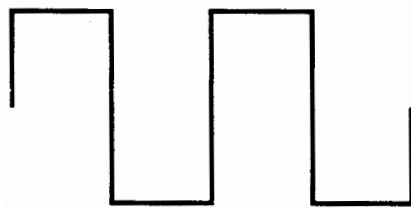

(b) SQUARE WAVE

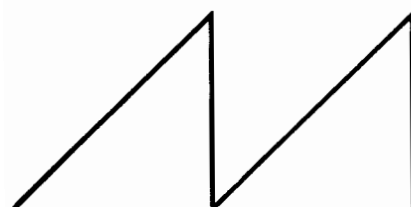

(c) SAWTOOTH WAVE

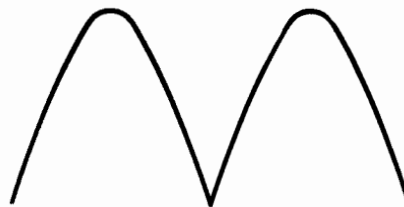

(d) RECTIFIED SINE WAVE

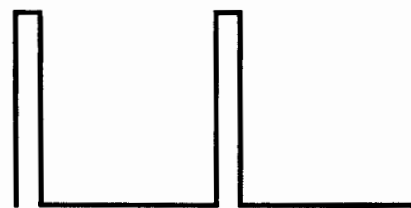

(g) PULSE

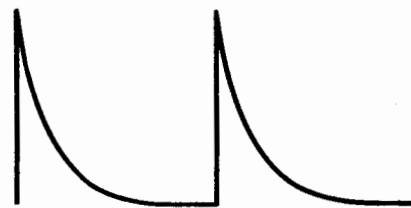

(f) EXPONENTIAL WAVE

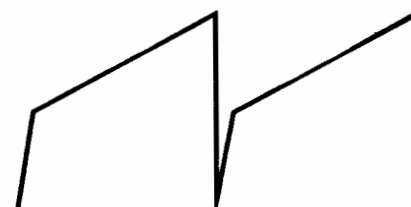

(e) TRAPEZOIDAL WAVE

FIG. 1

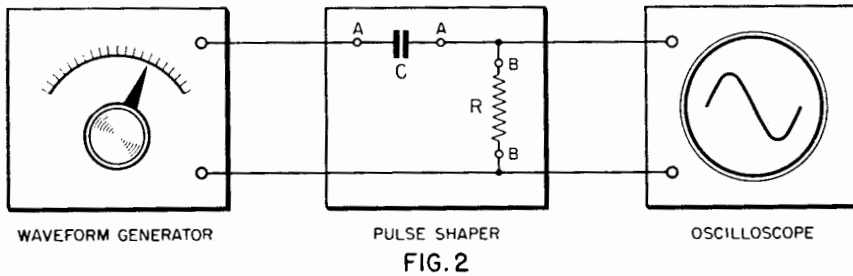

FIG. 2

resistor is, within certain limits, closely proportional to the *time derivative* of the input voltage. Other basic configurations of passive elements which are of importance are shown in Fig. 3.

We will first consider the R-C differentiator in some detail. It may be seen from a mathematical consideration that if the applied voltage in Fig. 2 is a pure sine wave, such as may be obtained from a good audio oscillator, the steady state output of the shaper will also be a pure sinusoid of identical frequency and waveform. In general, the only difference between the two will be their relative amplitudes and phases; the output leading the input by a phase angle given by:

$$(2) \quad \phi = \arctan \left[ \frac{1}{\omega RC} \right]$$

and reduced in amplitude as shown by the equation:

$$(3) \quad E_{out} = E_{in} \left[ \frac{1}{\sqrt{1 + 1/\omega^2 R^2 C^2}} \right]$$

Inspection of Eqs. 2 and 3 shows that the phase angle and attenuation both decrease with increasing frequency. It should also be noted that the phase angle may approach but never quite reach 90 electrical degrees for a single R-C differentiator, since a phase shift of 90 degrees requires that the total series circuit resistance be zero — in which case the output voltage would also be zero. Thus, the output voltage of an electrical differentiating circuit is never, in the mathematical sense, an exact time derivative of the input voltage.

A set of somewhat similar equations governing the phase and atten-

uation characteristics of the so-called R-L differentiators (Fig. 3b) for which the output voltage is proportional to the time derivative of the input *current*, rather than the input voltage as in the previous case, may be found in the literature. The phase shifting characteristic of resistor-capacitor and resistor-inductor networks is made use of where an accurately predetermined time or phase difference is required between trigger pulses. A typical phase shifter circuit which may be used to accomplish this is shown in Fig. 4. With this device, relative phase differences of almost 180 electrical degrees between input and either of the outputs, or nearly 360 degrees between outputs, may be readily achieved. Thus, although the phase shift for a single R-C or R-L network is limited to somewhat less than 90 degrees, it is possible to increase the total shift to any desired value by cascading two or more networks.

The "integrator" circuits (Fig. 3c and 3d) are so-named because of the fact that the output voltage is proportional to the time *integral* of either the circuit current (3c) or the applied voltage (3d). It should be mentioned in passing that the phase and attenuation characteristics of integrator circuits, which are essentially low-pass filters, are frequency dependant, like those of the differentiators (or high-pass filters) mentioned above. The major difference between the two is that integrators display (1) a lagging, rather than a leading phase angle, and (2) attenuation and phase angle which increase rather than decrease with increasing frequency.

Another type of differentiator circuit which, although little used in the

past, is of sufficient interest to warrant a brief discussion here is the transformer or "mutual inductance" type shown in Fig. 5. This circuit offers several distinct advantages over the previously described types. As in the standard R-L differentiator, the output voltage is again proportional to the time derivative of the input current as shown by the equation:

$$(4) \quad E_{out} = M \frac{di}{dt}$$

where M (the mutual inductance) is the proportionality factor relating the coefficient of coupling and the primary and secondary inductances. The transformer, like the R-C differentiator, is an a.c. coupled device, and as such provides more flexibility than does the R-L circuit, in which the input and output are conductively coupled. Thus, it is possible to use the transformer differentiator as a coupling device between two circuits operating at different d.c. levels (as in the plate and grid circuits of amplifier stages) without resorting to complicated biasing arrangements. Another advantage to the circuit is the comparative ease with which polarity reversal and voltage step-up may be effected, if desired.

An important concept which will aid in gaining a clearer understanding of the behavior of the passive wave shaping circuits of Fig. 3 is that of the *time constant*, T. Simply defined, T is the time in seconds required for an uncharged condenser C to charge through a resistor R to 63% of the applied voltage V. Conversely, for a charged condenser discharging through a resistance, T is equal to the time required for the voltage to decay exponentially to 37% of its initial value. In similar manner, T may be defined for an R-L circuit as the time required for the *current* to rise to 63% of its maximum value E/R, or as the time in which the current will fall to 37% of the initial value. The equations;

$$(5) \quad (a) T = RC \quad (b) T = L/R$$

are the mathematical conventions which have been adopted.

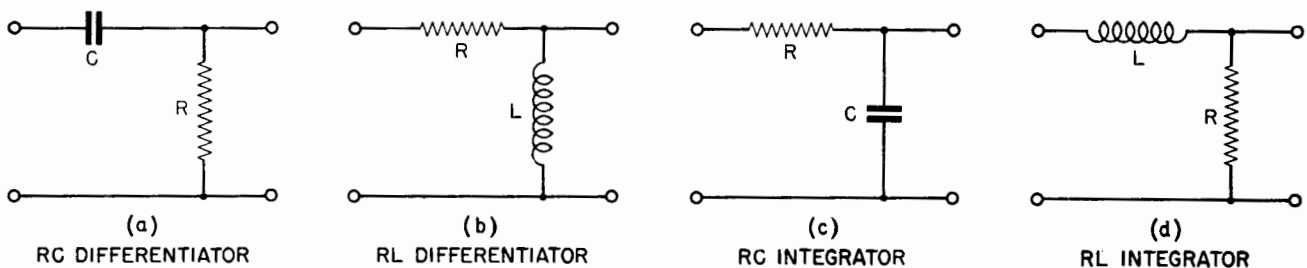

FIG. 3

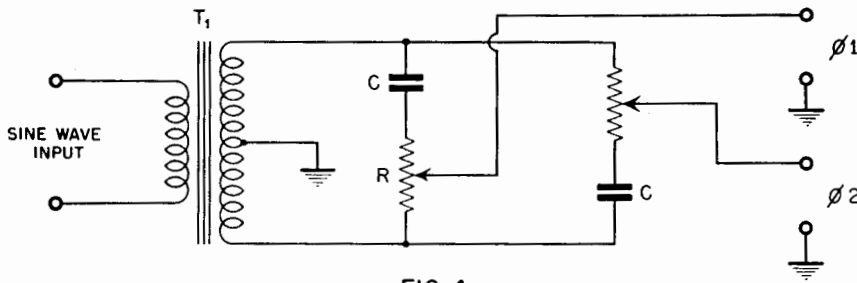
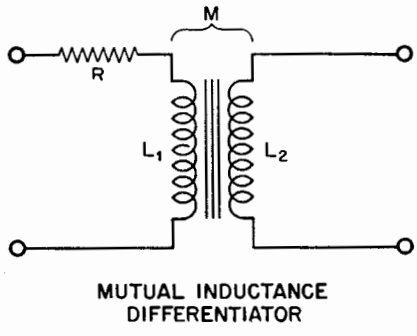

FIG. 4

Let us now consider the response of the circuits of Fig. 3 to non-sinusoidal waveforms. It will be remembered that for these circuits the input and output waveforms were identical under conditions of sine wave excitation, as mentioned above. Such is not the case for the non-sinusoidal waveforms, however. If, for example, a square wave of voltage (Fig. 1b) is applied to the input of either type of differentiator shown in Fig. 3, the nature of the output voltage developed depends on the value of the time constant  $T$  in relation to the period  $t$  occupied by one cycle of the input voltage. If the ratio  $T/t$  is small, the output under these conditions will appear as a succession of alternatively positive and negative pulses which are narrow near the peaks but broader at the base as in Fig. 6a.

The output of an integrator circuit, on the other hand, with similar square



MUTUAL INDUCTANCE DIFFERENTIATOR  
FIG. 5

wave excitation and time constant, will resemble Fig. 6b. As may be inferred by comparison of Figs. 6a and 6b with the original square wave, it can be said in a more or less qualitative manner that the differentiator circuits transmit only the higher order frequencies contained in a complex waveform, while the integrator networks, conversely, pass only the lower frequency components.

The qualitative analysis of the preceding paragraph may be extended to include waveforms other than the square wave. For example, consider the sawtooth wave shown in Fig. 1c. The output of a differentiator with sawtooth excitation will, for large values of  $T$ , resemble the input in shape. As  $T$  decreases, the waveform will in general be distorted as shown by Fig. 6c. This distortion of a given complex waveform by passive networks has been recognized by Weidelich<sup>3</sup>, Rockett<sup>4</sup>, and others as providing a rapid method of checking circuit and amplifier characteristics. Since the sawtooth waveform contains both even and odd harmonics of the fundamental, as compared with the square wave which contains only odd harmonics, the use of the former in such applications will result in a much more complete picture of amplifier performance.

Integrator and differentiator circuits have received their widest applications in the home television receiver field. Here they serve the function of separating the high fre-

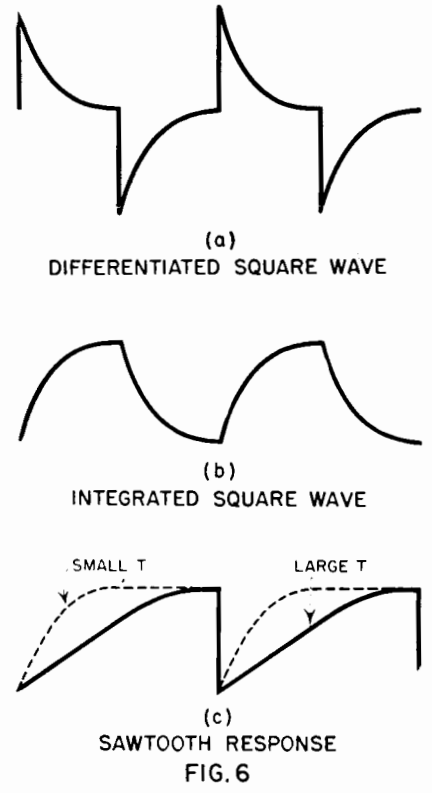

FIG. 6

quency horizontal pulses and the low frequency vertical pulses from the composite "sync" signal which contains both horizontal and vertical synchronization information. The time constants of the sync separators must be so adjusted that none of the horizontal sync pulses appear at the output of the integrator, and none of the vertical sync pulses appear at the output of the differentiator. In this application, the integrators are usually made up of two or three cascaded sections in order to assure more perfect separation and also to provide comparative freedom from random electrical disturbances such as auto ignition interference. Part 2 will discuss typical generators for production of non-sinusoidal waveforms as well as wave shaping networks employing non-linear elements.

# Non-Sinusoidal Wave Forms

## Part 2, Generators and Non-Linear Shapers

IN Part 1, the response of four-terminal passive wave-shaping networks to various types of applied waveforms was discussed without regard to the actual generation of these waveforms. The fol-

lowing paragraphs will be concerned with a description and discussion of several of the more basic methods of generating non-sinusoidal waves.

Pulse generators as a general class

fall into two rather loosely defined categories; the self-excited or self-sustaining generators such as the gas tube relaxation oscillator, the block oscillator, the multivibrator, etc., and the

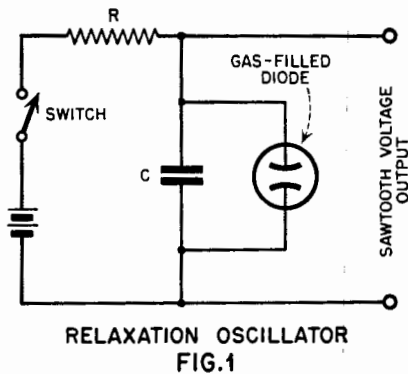

"driven" generators such as the squaring amplifiers, limiters and rectifiers. The self-excited generators require no input other than the usual d.c. operating potentials (plus a synchronizing or triggering signal if desired for improved stability), and are self sustaining as long as the d. c. power is applied. They operate on the rather simple principle that any system—electrical, acoustical, or mechanical—having two stable states of equilibrium may oscillate between these states if a sufficient amount of its output energy is fed back to the input in the correct phase. Thus, it will be readily seen that the escapement of a watch movement satisfies these conditions and is therefore a mechanical relaxation oscillator. The primary source of energy in this case is the potential energy stored in the spring.

Among the electronic pulse generators to be discussed is the familiar gas tube relaxation oscillator first used in the "dark ages" of electronics as an oscilloscope time-base generator. Briefly, the sequence of action in such a device, shown diagrammatically in Fig. 1, is as follows. After switch closure, condenser C charges exponentially through resistor R, the condenser voltage at any time being given by:

$$(1) \quad e = E \left( 1 - e^{-\frac{t}{RC}} \right)$$

Where:

- e is the instantaneous condenser voltage
- E is the battery voltage
- e is the base of Napierian logarithms
- t is the time in seconds after switch closure
- R is the resistance in ohms
- C is the capacitance in  $\mu\text{fd}$ s

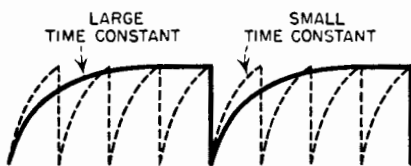

**FIG. 2**

If the gas tube were not in the circuit, the condenser voltage would in time be equal to the full battery voltage. However, when a gas diode having an "ignition" potential somewhat lower than the battery voltage is connected as shown in Fig. 1, the condenser voltage at some point on the charging curve will be sufficient to ionize the gas, rendering it conductive. In this condition the tube serves as a discharge path for the charge stored on the condenser. The condenser voltage will decay exponentially toward zero until it reaches the "extinction" voltage of the gas tube permitting deionization to take place, where upon the condenser voltage again charges toward the ignition potential and the cycle repeats. The output voltage for large values of the RC time constant is the distorted sawtooth shown as the solid line of Fig. 2. Also shown (dotted lines) is the output voltage for identical battery voltage and gas tube conditions but with a small time constant (RC). With this simple relaxation generator, the output must be limited to about 5 or 10 percent of the supply voltage if a linear sawtooth is desired.

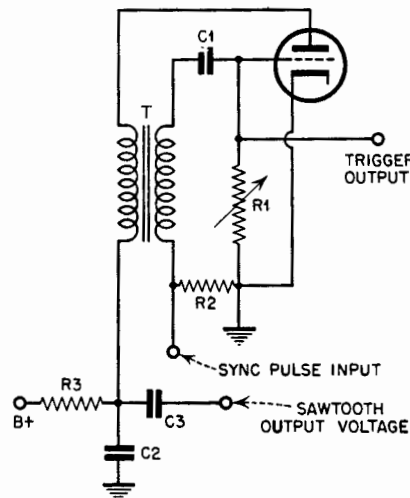

**BLOCKING OSCILLATOR**  
**FIG. 3**

As a refinement, the gas diode of Fig. 1 may be replaced by a gas-filled triode, or *thyatron*, and the charging resistor by a constant current source such as the plate resistance of a pentode. With these modifications, a much larger portion of the supply voltage appears as linear sawtooth at the output of the generator. In addition, it is relatively easy to inject a synchronizing pulse into the grid circuit to insure that the sawtooth generator will "lock in" synchronously with some desired repetition frequency.

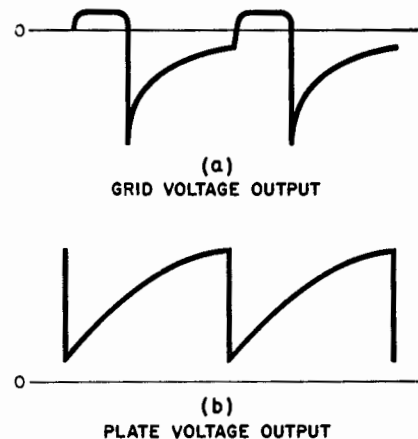

**BLOCKING OSCILLATOR WAVEFORMS**  
**FIG. 4**

A pulse of very short duration may be obtained from the gas tube type of generator by inserting a resistor into the cathode circuit of the thyatron. The voltage pulse across this resistor is, of course, proportional to the discharge current pulse of the condenser, and may be made of short duration by the proper choice of tube and circuit parameters.

The blocking oscillator, Fig. 3, has been widely used in television receivers as a pulse generator for accurately timing the sweep generator. Here again the *modus operandi* is the relaxation principle, with an iron core transformer serving as the feedback coupling mechanism. The transformer must of necessity be so phased that an increase in plate current causes an increase in grid voltage in the positive direction, and vice versa. Under these conditions the slightest fluctuation of plate current is sufficient to drive the tube either to cutoff or plate-saturation, depending on the polarity of the initial disturbance.

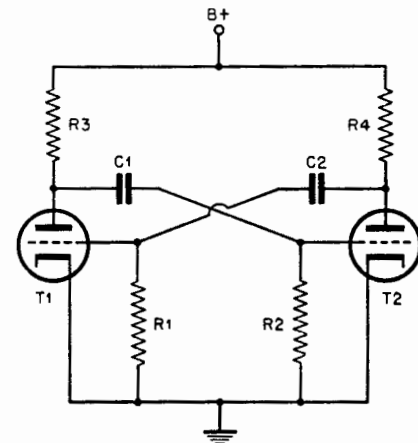

**MULTIVIBRATOR**  
**FIG. 5**

For a positive-going disturbance, the plate current will increase until the rate of rise of plate current decreases sufficiently to make the rate of change of net grid voltage negative, at which time the plate current falls to zero. During the fall of plate current, as well as during the rise, the transformer phasing dictates that the rate of change of current shall be extremely rapid. Since the grid draws appreciable current during a portion of the cycle, once the plate current has fallen to zero, it will remain cut off until the accumulated negative charge on the grid condenser (and consequently the net grid voltage) becomes sufficiently small to again permit the flow of plate current. As may be seen, the cycle is repetitive and self-sustaining.

Fig. 4 depicts typical grid and plate voltage waveforms observed in blocking oscillators. The grid voltage may be used as the trigger pulse to fire a discharge-tube type of television sweep generator which will be discussed later, or the plate output may be used directly as the shaped sweep waveform. Both methods have been used satisfactorily in commercial television receivers.

Synchronization of a blocking oscillator may be accomplished by injecting a positive sync pulse into the grid circuit as shown in Fig. 3. For best results, the free-running frequency of the blocking oscillator (controlled by  $R_1$  of the above figure) should be slightly lower than the frequency of the sync pulses, although synchronization with multiples or sub-multiples is possible.

Several modifications of the free-running blocking oscillator should also be mentioned. For example, if sufficient negative bias is applied to the grid, self-sustained oscillations may be prevented. This circuit, called a "driven blocking oscillator", will oscillate for only one cycle each time a trigger pulse is applied. Another

useful variation is the "positive grid blocking oscillator," in which the grid is operated with a slight positive bias to reduce random pulse-to-pulse time "jitter".

Closely related to the ordinary blocking oscillator is the generator first referred to in British literature as the "squegging" oscillator. In this circuit, the feedback mechanism is an r.f. transformer. The action of this type is similar to that of the blocking oscillator, with the significant exception that, instead of the single burst of plate current normally occurring in the blocking oscillator, there may be several cycles of r.f. oscillations generated before sufficient charge accumulates on the grid condenser to cut the tube off. This action, incidentally, is identical with that occurring in superregenerative detectors. Squegging oscillators have been tried as rather primitive radar transmitters, but the synchronization problems involved have precluded their wide usage.

Another circuit which may be used as a non-sinusoidal wave generator is the multivibrator. In its simplest form (Fig. 5), this may be thought of as a two stage, resistance coupled amplifier whose output and input are regeneratively coupled. The circuit operation may be readily understood by recognizing that two stable states are possible; tube No. 1 conducting when tube No. 2 is cut off, and vice versa. The tube that is cut off will remain in that condition until the negative voltage charge accumulated on its grid condenser during the grid conduction period has decayed sufficiently to permit plate current to flow. The light feedback coupling makes the build-up of current extremely rapid. When this occurs, the phasing is so arranged that the other tube will be cut off, and the cycle repeats. Like the blocking oscillator, the multivibrator may be synchronized by injecting a sync pulse into either grid circuit.

As mentioned above for the blocking oscillator, the free-running multivibrator may be altered in several ways from varying applications. If, for example, the circuit is arranged so that one tube is permanently biased to cutoff, and a positive trigger pulse is applied to its grid, the circuit will complete only one cycle of multivibrator action and return to the most stable state — that of the permanently biased cutoff condition. This type of multivibrator, called a Kipp relay, may be further modified by removing the condensers and providing conductive feedback paths. With this circuit, the tube that is cut off will remain in that condition until triggered by a positive pulse. The circuit will flip to the other equilibrium condition with the other tube cut off, and will remain that way until it too is triggered similarly. The shift occurs only once for each triggering impulse applied.

The output of a symmetrical multivibrator will be the square wave illustrated in Fig. 1b of Part 1. The term "symmetrical" implies that the values of resistance and capacitance in the grid and plate circuits of one of the tubes are equal, part for part, to those of the other tube. For this circuit, the frequency of oscillation is given by:

$$(2) \quad F = \frac{1}{2RC}$$

Where:

- F = frequency in cycles per second
- R = resistance of the grid resistor in ohms
- C = capacitance of the coupling condenser in ohms

A convenient method of varying the frequency is by using a dual potentiometer as the grid resistors.

In the unsymmetrical multivibrator, i.e., one in which *unequal* values of grid resistors and coupling condensers are employed, the output waveforms will resemble Fig. 1g of Part 1.

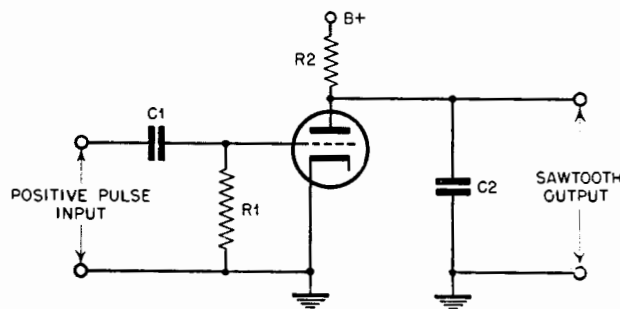

DISCHARGE-TUBE SWEEP GENERATOR  
FIG. 6

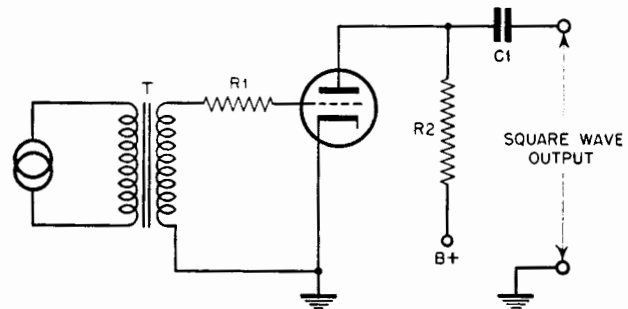

OVERDRIVEN AMPLIFIER  
FIG. 7

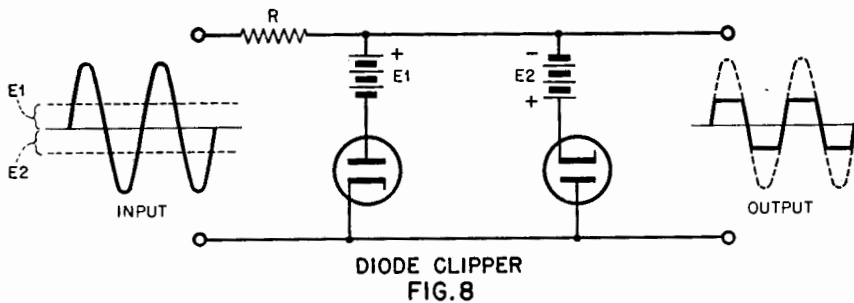

DIODE CLIPPER  
FIG. 8

The sawtooth sweep generator referred to as the "discharge tube" in commercial television practice is a simple circuit (Fig. 6) whose operation is quite similar to that of the gas tube relaxation oscillator discussed above. Here, however, the discharge occurs when the grid potential is made positive enough to reduce the plate resistance of the tube to a small value. Between pulses, of course, the voltage across the storage condenser rises more or less linearly and, if limited to about 5% of the supply volt-

age, may be used as the sweep voltage waveform of a television receiver.

In conclusion, a brief description of typical *driven* waveform generators, such as the overdriven amplifier and the limiting diode circuits, will be given. The overdriven amplifier (Fig. 7) consists of a conventional amplifier tube and associated circuit which is operated in such a manner that both plate and grid limiting occur. If a large sinusoidal voltage is applied to the input, the tube is driven beyond cutoff during most of the negative excursion of the sine wave.

During the positive portion, however, the grid will draw current, which is limited by the series grid resistor. Under these conditions, it is impossible for the grid voltage to rise more than just a few volts positive, no matter how high the input signal goes. Thus, the plate current is also limited. The output will be a square wave. By properly choosing the values of the circuit elements, the limiting action may be made to occur over a wide range of signal amplitudes. Thus, it is possible to convert any complex waveform into a flat-topped waveform.

The circuit of Fig. 8, variously termed a diode clipper, clamper, or limiter, performs a similar function. Any waveform applied at the input terminals will be clipped at a voltage level determined by the bias voltage in series with each diode. This circuit provides a simple method of converting a sine wave to a square wave. Diodes of either the vacuum tube type or the crystal type may be employed.

## Audio Frequency Distortion Measurements

### Part 1, Methods of Measurement

THIS is Part 1 of a series of two which will deal with audio frequency distortion measurements. Part 2 will give details of a simple, practical instrument designed to measure distortion in audio amplifiers.

The acoustical quality of an audio amplifier is related to the amount of distortion prevalent in the amplifier. If conforming to true Class A operation, the output plate current waveshape of the amplifier should duplicate the waveshape of the grid voltage input. Such not being the case, the amplifier has a certain percentage of harmonic distortion which, if excessive, deteriorates the audio quality and becomes annoying to the listener.

#### Types of Distortion

There are three types of distortion found in an amplifier; (1) amplitude distortion (2) frequency distortion, and (3) phase shift. In amplitude distortion, the fundamental plus harmonics are observed in the output. Frequency distortion is caused by the amplifier's inability to amplify all frequencies equally. Phase shift is

present when the amplifier has different delays for all frequencies. The amount of distortion increases as the tube is operated outside of the linear portion of the tube characteristic curve, as shown in Fig. 1.

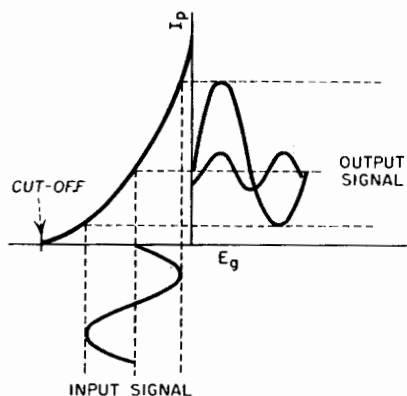

DISTORTION IN  
NON-LINEAR AMPLIFIER

FIG. 1

In addition to harmonic distortion, there is intermodulation distortion in audio amplifiers. Both are caused by non-linearity in the amplifier. Intermodulation results in the production of frequencies equal to the sums and differences of a low and high frequency (and harmonics). The intermodulation products of fundamental frequencies  $F_1$  and  $F_2$  are as follows:

$$F_1 + F_2 \text{ and } F_1 - F_2$$

$$2F_1 + F_2 \text{ and } 2F_1 - F_2$$

$$F_1 + 2F_2 \text{ and } F_1 - 2F_2, \text{ etc.}$$

The intermodulation products do not resemble the original tones in the input.

Intermodulation distortion measurements more closely correspond to the non-linear distortion detected by the average radio listener than does a measurement of total harmonic distortion. It is interesting to note that intermodulation distortion can be observed even after no harmonic distortion is measurable.

The percentage of total harmonic distortion, represented as the distortion factor, is equal to:

(1)

$$\sqrt{\frac{\text{Sum of squares of harmonic amplitudes}}{\text{Sum of squares of fundamental and harmonic amplitudes}}} \times 100\%$$

and is measured on the distortion meter. The distorted wave shape can be represented by the Fourier series, and the relative values of the terms of the series indicate the amplitudes of the harmonics in the complex wave.

The harmonic content of the signal includes all of the components which are higher in frequency than the fundamental. Signal components which are lower than the fundamental, such as noise from the power supply, are not usually measured. Total harmonic distortion measurements are most frequently made at 400 or 100 cycles per second. Even though this is the standard practice, additional distortion will usually be present at the lower frequencies. The Federal Communications Commission recommends a measurement of harmonics in audio equipment at frequencies of 30, 50, 100, 400, 1000, 5000, 7500, and 15,000 cps.

#### Distortion Meter

Audio frequency distortion measurements can be made by using distortion meters, harmonic wave analyzers and intermodulation analyzers. The distortion meter will be discussed first.

A distortion meter gives the percentage of total harmonic content and does not show how much of each harmonic is present in the output. A block diagram of the meter is shown in Fig. 2. Basically, it consists of a null bridge and a vacuum tube voltmeter. The null bridge is tuned to the fundamental such as 400 cycles per second and the bridge is balanced at this frequency to entirely remove the fundamental. The vacuum tube voltmeter will then measure only the amplitude of the harmonics. For accurate measurements, the oscillator generating the fundamental test fre-

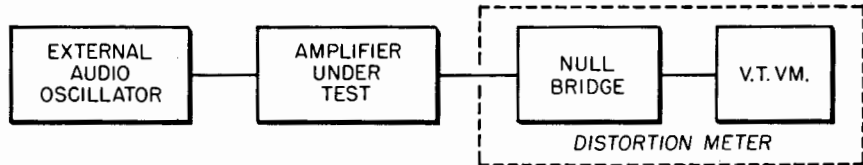

TEST SET-UP USING DISTORTION METER  
FIG. 2

quency should be completely free of harmonics. In addition, the VTVM should represent the RMS voltage as truly as possible. This can be insured by operating the VTVM in a manner such that the square root of the plate current versus grid voltage is a linear function.

The distortion meter does not indicate which frequencies are present in the complex-distorted wave and the relative amplitude of each. In addition, certain random noises may be very disturbing to the listener and yet show only a small indication on the meter. Therefore, as in many test measurements, the operator must show sufficient skill to translate the results obtained with the meter into useful data.

A typical commercial distortion meter has a frequency range from 50 to 15,000 cps. The distortion percentage is read directly from a meter with calibrated full-scale deflections of 0.3%, 1%, 3%, 10% and 30% distortion. A diode vacuum tube voltmeter is used for measuring the percentage of total harmonic distortion. The scale is also calibrated in decibels. A 100,000 ohm unbalanced and a 600 ohm balanced bridge input circuit are provided. Distortion measurements are made on this instrument with an accuracy of approximately 5%. A distortion-free sine wave oscillator should be used with the meter. Otherwise a residual reading will be measured which represents the oscillator distortion rather than that of the amplifier or other audio device being tested. There should be no distortion even at the very low audio frequencies.

#### Harmonic Wave Analyzer

Unlike the distortion meter, the harmonic wave-analyzer is a precision method of measuring distortion and indicating separate components. The wave-analyzer tells the operator which frequencies other than the fundamental are in the complex waveform and also gives the amplitude of each harmonic.

Since the analyzer must determine the fundamental frequency and all of the harmonics, it is necessary that the instrument be capable of tuning to each of these frequencies and of measuring the amplitude of each. The analyzer is really nothing more than a highly selective vacuum tube voltmeter, and is similar to the conventional superheterodyne receiver except that the intermediate frequency is much higher than the input audio signal under observation. The wave analyzer has a very narrow bandwidth, otherwise measurements of harmonics components at the very low audio frequencies would be impossible.

The most commonly known wave analyzer is the heterodyne type. A block diagram is shown in Fig. 3 and is representative of a commercial analyzer. The incoming audio signal is heterodyned with the frequency from a variable frequency oscillator and the resultant frequency is amplified by the narrow bandwidth IF amplifier and read on a vacuum tube voltmeter. When the difference between the oscillator and the input signal frequency is 50Kc, the signal will be tuned to the IF amplifier and the amplitude can be measured on the VTVM. The three-crystal filter

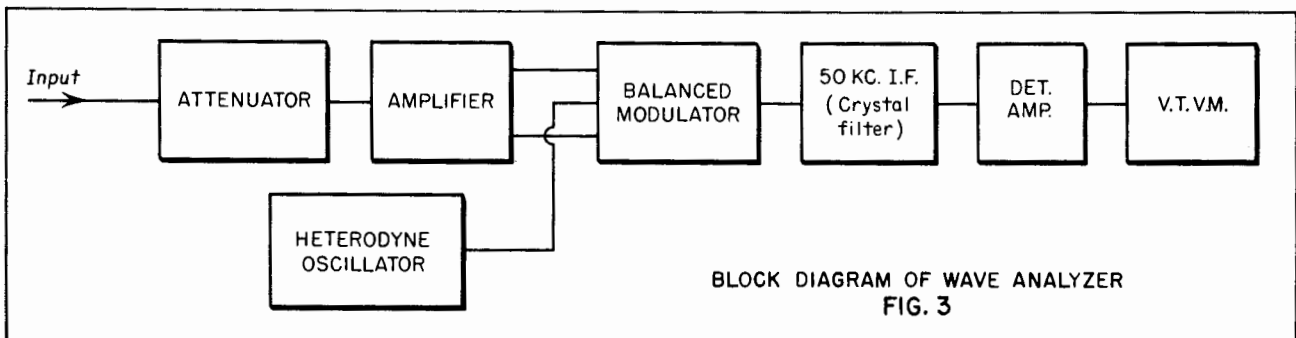

BLOCK DIAGRAM OF WAVE ANALYZER  
FIG. 3



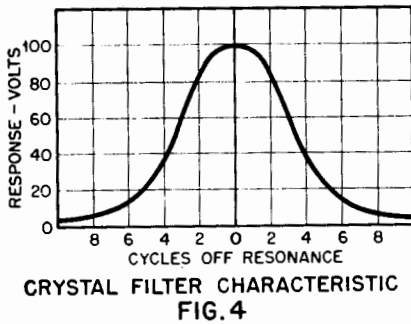

incorporated in the IF amplifier assures a very high selectivity. A response curve of the crystal filter is shown in Fig. 4. The heterodyne oscillator covers a frequency range of 34,000 to 49,980 cycles per second but the dial is calibrated from 0 to 16,000 c.p.s. Assume that the incoming signal is 500 c.p.s. This would correspond to an oscillator frequency of 49,500 since 49,500 plus 500 c.p.s. equals 50 kilocycles. A difference frequency  $f_1 - f_2$  (49,500—500) cannot be amplified. The bandwidth is only 4 cycles and harmonics can be measured easily at the lowest audio frequencies. The input impedance is one megohm, which is sufficiently high to make loading effects negligible. The VTVM is directly calibrated in volts and decibels and a 5% voltage accuracy is obtained on all ranges from 300 microvolts to 300 volts full scale. The frequency calibration is accurate to  $\pm$  (2% — 1 cycle).

Another commercial wave-analyzer has the feature of variable selectivity for rapid analysis of the complex wave. Where the harmonics are spaced far apart, the bandwidth may be increased, thus making it easier to make measurements. If the harmonics are closely spaced, as at the very low frequencies, the instrument may be made more selective, to separate harmonics 30 cycles apart. A response curve of this analyzer is shown in Fig. 5.

The operation of a wave analyzer involves first tuning the oscillator dial

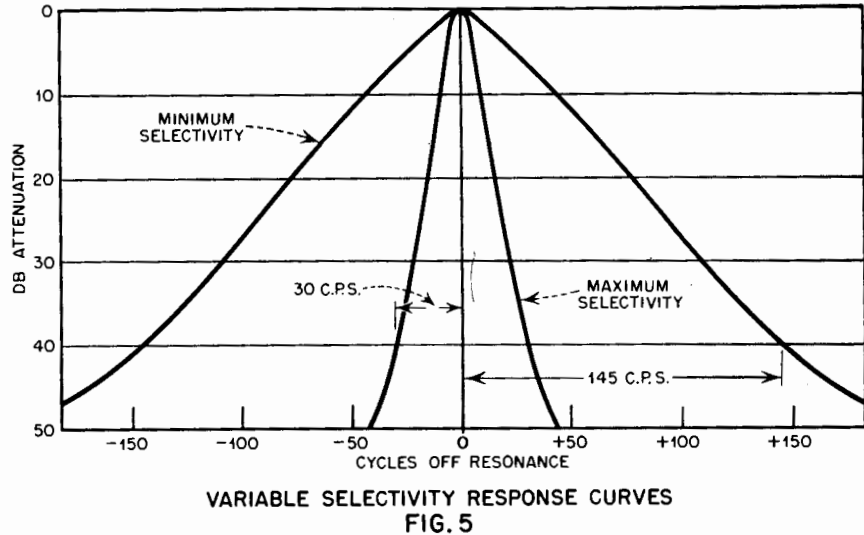

to the fundamental and then adjusting the attenuator until the meter reads full scale. Then the harmonics are found by changing the oscillator frequency dial and recording the amplitude of each.

In addition to its use for measuring the distortion in an amplifier, the wave-analyzer can be used for measuring distortion in oscillators, transmitters and telephone systems. It can also be used to determine the harmonics in power machinery and to analyze noise characteristics.

#### The Intermodulation Analyzer

A block diagram of a typical commercial intermodulation distortion meter is shown in Fig. 6. The amount of distortion is maximum at the highest and lowest transmitted frequencies. However, this discussion will be concerned mainly with intermodulation distortion measurements at the very low audio frequencies. At low frequencies, maximum power output from a tube is not realized because of impedance changes in transformers and reactances. The power output is similarly reduced at the higher frequency because of increased leakage and distributed capacity.

The operation, two frequencies shown on the diagram (Fig. 6) as 100 and 7000 c.p.s. are combined in the mixer. The purpose of the 7000 c.p.s. signal is to act as a carrier for the low frequency components. These two frequencies are commonly used, but a lower frequency ratio must be used if the amplifier under observation has insufficient bandpass. For best sensitivity, the amplitude of the lowest frequency should be 12db above the higher frequency—a voltage ratio of 4 to 1. The output of the mixer is fed to the amplifier under test and its harmonics. The resultant signal, which is 7000 c.p.s. modulated by 100 c.p.s., is amplified and demodulated by the rectifier. It is then fed to a low pass filter to eliminate 7000 c.p.s., and the output is fed to a VTVM where the intermodulation products are present and the percent of intermodulation distortion is read directly from the meter.

There is no direct relationship between the percentage of total harmonic content and the percentage of intermodulation distortion. With a 12 db ratio for the above frequencies, some authorities claim the percent intermodulation distortion is

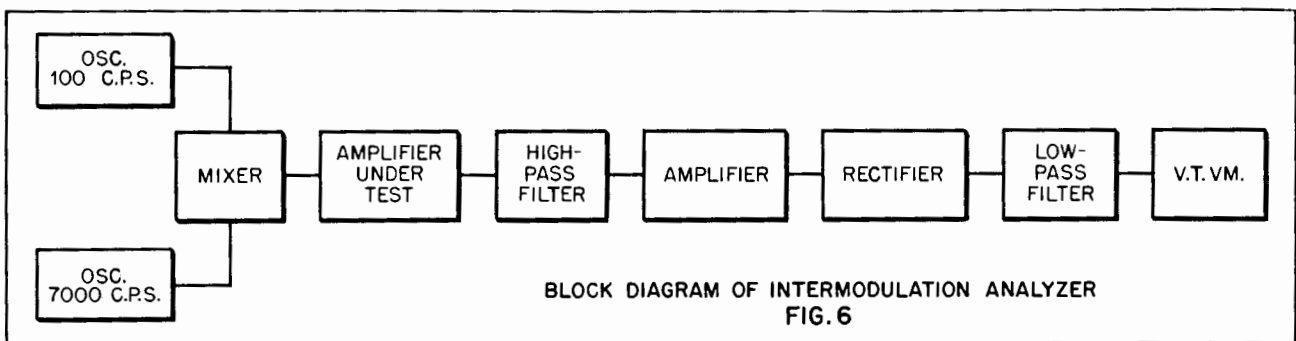

equivalent to;

$$(h_1, h_2, h_3, \dots, h_n) \times (n)$$

where  $h_1, h_2$ , etc. are the harmonics and  $n$  is the order of harmonics. As an example, 10% intermodulation distortion is often equivalent to about

2.5% total harmonic distortion. Since there are no definite standards for these measurements, any figure of intermodulation distortion must be accompanied by a statement of test conditions.

It is hoped that this brief discussion of audio frequency distortion

measurements will be helpful in clarifying the general subject distortion measurements. Part 2 will be especially helpful to those who wish to construct a simple meter for rapid measurement of the percentage of total harmonic distortion and identification of harmonic wave components.

# Audio Frequency Distortion Measurements

## Part 2, A Practical Distortion Analyzer

Part 1 of this series contained a discussion of the nature of audio frequency distortion and a survey of the methods employed in making quantitative distortion measurements on audio equipment. The present discussion details the design and construction of a simple and practical distortion analyzer which is a very useful adjunct to any amplifier service shop or audio high fidelity experimenters bench. The instrument is compact, easy to adjust and use, and costs little to build. Yet, the results obtained are sufficiently accurate to permit evaluation of the performance of most audio equipment and observation of the results of even minor design changes.

As was pointed out in Part 1, the simplest form of distortion meter employs a null bridge to suppress the fundamental test frequency being amplified under test and a vacuum tube voltmeter to read the amplitude of any signals which pass unattenuated through the null bridge. If the signal input to the amplifier is a pure sine wave of frequency equal to the null frequency of the bridge, the only signals indicated by the voltmeter will be the harmonics introduced by distortion in the amplifier being tested. If the response of the voltmeter is linear, it is easy to express the total harmonic content thus indicated as a percentage of the amplifier output.

### The Distortion Analyzer

The major shortcoming of the null bridge type of distortion meter, as it is usually employed, lies in its inability to identify the order of the harmonic content indicated. It reads total percentage of distortion and thus may only be classed as a distortion meter. To be considered a distortion analyzer, the instrument should be capable of identifying each harmonic component present and indicating

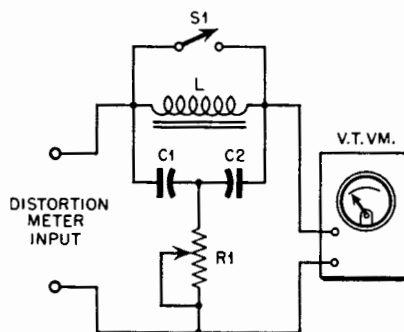

BASIC DISTORTION METER  
FIG. 1

their relative amplitudes. Commercial distortion analyzers which accomplish this are both complicated and costly. However, a simple system is available which is not appreciably more complicated than the common null bridge distortion meter, but is capable of considerably better results. Its use is predicated upon the availability of a second audio oscillator.

The circuit of a typical null bridge distortion meter is shown in Fig. 1. The components  $L, C_1, C_2$  and  $R_1$

constitute the null bridge network which suppresses the frequency at which  $L$  and the series combination of  $C_1$  and  $C_2$  are resonant, as given by:

$$(1) \quad \text{Null frequency } (f) = \frac{1.414}{2\pi\sqrt{LC}} \text{ cycles per sec.}$$

Where:  $L$  is the choke inductance in henries.  
 $C = C_1 = C_2$  is the capacitance of each unit in farads.

The circuit configuration will be recognized as the "bridge-T" type of network. The resistance ( $R_1$ ) is used to adjust the null reading to minimum. If the circuit constants are chosen properly, and distributed capacitance is minimized, virtually zero transmission will occur at the null frequency. If the null circuit "Q" is high, the null will be very sharp and nearby frequencies will be very slightly affected. The voltmeter is used to measure both total amplifier output and harmonic output by shunting out the bridge circuit with the switch ( $S_1$ ) during the former measurement. A vacuum tube voltmeter may be employed, as illustrated in

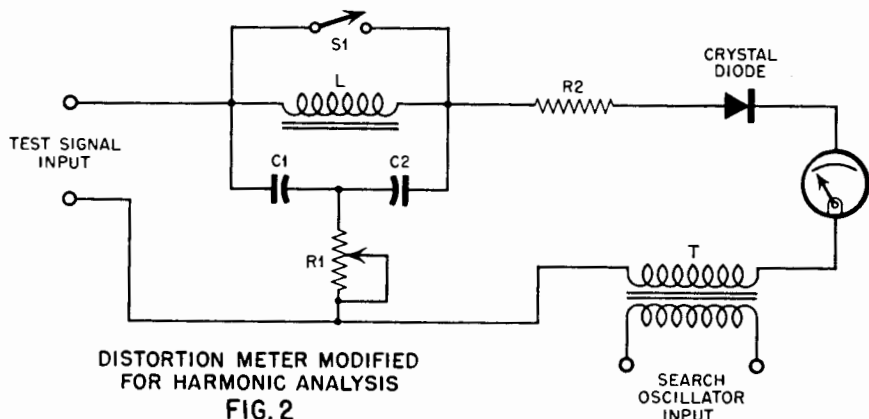

DISTORTION METER MODIFIED  
FOR HARMONIC ANALYSIS  
FIG. 2

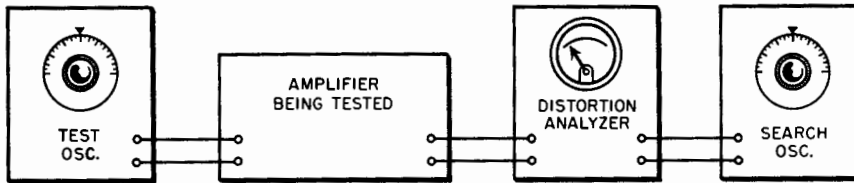

TEST SET-UP FOR DISTORTION MEASUREMENTS  
FIG. 3

Fig. 1, or a simple crystal diode voltmeter may be used with only a slight sacrifice in accuracy.

To convert the distortion meter of Fig 1 to a distortion analyzer, the modification shown in Fig. 2 is made. An audio transformer is added to permit the insertion of a sine wave signal from a second audio oscillator. This signal is used to identify individual harmonic components present in the bridge output by the beat method. To accomplish this, the second oscillator is swept through the frequency range containing the harmonics of the fundamental test signal. Fig. 3 is a block diagram of the complete test set up. Near the frequency of each harmonic present, a "beat" will be observed in the distortion meter reading. The amplitudes of the beats are indicative of the relative magnitude of each harmonic component identified. Thus, a quantitative indication of harmonic content, as well as total harmonic percentage, is obtained.

As an example, suppose that the test frequency is 400 cycles and the distortion meter indicates a total harmonic distortion of 10% before the introduction of the "search" oscillator. If there is both second and third har-

monic distortion, an amplitude beat will be observed when the second oscillator is swept through 800 and 1200 cycles. If the second harmonic predominates, the beat at 800 cycles will be greater than the one at 1200 c.p.s. in the same proportion. Knowing the total harmonic distortion, it is easy to evaluate the percentage of each harmonic component. The search oscillator frequency should be adjusted close enough to the harmonic frequency to give nearly zero beat, so that the meter needle can follow. The oscillator used for searching should be relatively free of harmonic output.

#### Construction Details

The practical circuit diagram of the distortion analyzer is given in Fig. 4. Since no vacuum tubes or power sources are required for its operation, the unit may be assembled in very compact form. A crackle-finish metal cabinet measuring 6"x6"x6" affords more than sufficient space to mount all components. No chassis is used; all parts are mounted on the front panel except the choke (L) and the audio transformer (T) which are supported by a sheet-metal shelf fastened to the back of the removable

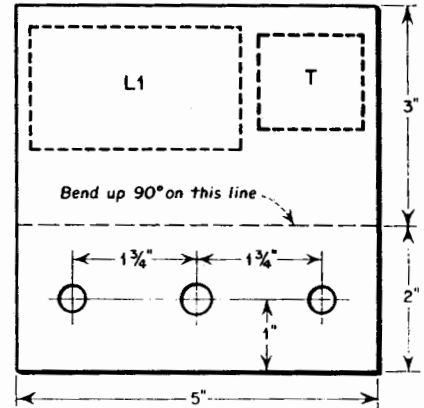

DETAILS OF SHELF  
FIG. 5

front panel by means of the shaft bushings of R1, R2, and S2 (Fig. 4). The dimensions of this shelf and the approximate locations of the parts mounted on it are shown in Fig. 5. The suggested front panel lay-out is shown in Fig. 6.

To assure maximum versatility, three null bridge frequencies; 400, 1000 and 5000 cycles, are provided. These frequencies are selected by substituting the proper capacitance values for C1 and C2. Capacitor switching is done with a two-circuit, three-position wafer switch. If additional or alternative test frequencies are required, the necessary capacitor values may be computed from:

$$(2) \quad C_1 = C_2 = \frac{1}{158 f^2} \text{ farads} \quad \left( \begin{array}{l} \text{for} \\ 8 \text{ henry} \\ \text{choke} \end{array} \right)$$

Where:  $f$  is the desired null frequency.

For most routine amplifier testing, the three frequencies for which values are given in Fig. 4 will be sufficient.

For effective fundamental frequency rejection with low harmonic frequency attenuation, the "Q" of the null bridge components must be high. Best quality components should be used for the resonant circuit comprising C1, C2 and L1. The choice of the choke is important since the resistance as well as the inductance of this unit is critical. The resistance of the choke will adversely affect the "Q" of the null circuit if too high.

Some selection of capacitors may be necessary to arrive at any given test frequency, although for most practical purposes it is not necessary to measure distortion at exactly the frequencies specified.

The null resistor (R1) is a variable one megohm potentiometer mounted

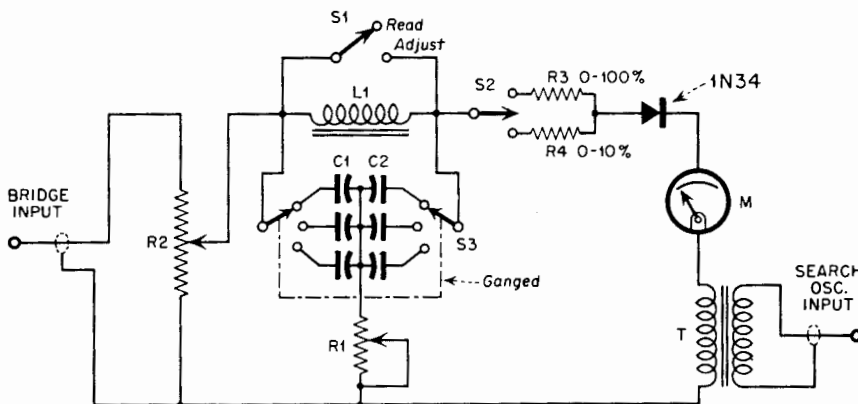

R1 - 1 megohm, carbon.  
R2 - 1000 ohm, wire wound.

R3 - 30,000 ohms, 1/2 watt carbon.

R4 - 2000 ohms, 1/2 watt carbon. (Approx.)

S1, S2 - S.P.D.T. toggle switch.

S3 - 2gang, 3 position wafer switch.

L1 - 8 hy. 150 ohm choke.

T - See text. M - 0-100 microamperes.

CRYSTAL - 1N34 or equivalent.

C1, C2 - 400 C.P.S. .04  $\mu$ fd

- 1000 C.P.S. .006  $\mu$ fd

- 5000 C.P.S. .00025  $\mu$ fd

PRACTICAL DISTORTION ANALYZER  
FIG. 4

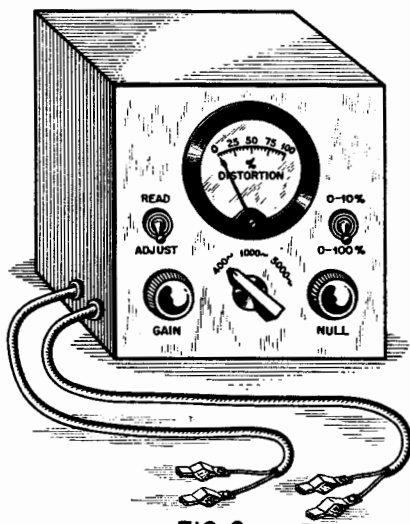

FIG. 6

on the front panel and provided with a small knob. This control is used to adjust the null response to minimum at each of the test frequencies. The setting of R1 usually remains fixed for any given frequency.

The crystal diode voltmeter uses a 1N34 or any of the germanium crystals as a rectifier. It gives a response that is approximately linear with input voltage if a high sensitivity meter is used. A 0-100 microampere meter is ideal, since the scale calibration can be used to indicate distortion percentage directly. Otherwise, any meter requiring less than about 250 microamperes for full scale deflection may be employed. Above this current, the average crystal diode characteristic departs markedly from linearity.

Two meter ranges are provided to allow more accurate reading of distortion percentages. These ranges, 0-100% and 0-10%, are selected by switching meter multiplier resistors R3 and R4 by means of a toggle switch (S2). The multiplier resistor for the 0-10% scale is selected to give full scale deflection at 1/10th the rms

input voltage required to give full scale reading on the 0-100% range.

The audio transformer (T) may be almost any unit of good quality which the experimenter might have available. The characteristics are not critical, since this transformer is used merely to introduce a small audio voltage from the search oscillator into the voltmeter circuit. A good 3:1 interstage audio transformer will usually be found satisfactory.

The audio input cable to the bridge circuit, as well as the external lead to the search oscillator, are run through holes in the left hand side of the metal cabinet and wired permanently to the circuit. These leads are of standard single-conductor shielded audio cable and are fitted with alligator clips at the input ends. The cabinet holes should be fitted with rubber grommets.

#### *Using the Distortion Analyzer*

The use of the instrument is relatively simple. After the construction has been completed, the operation of the null bridge circuit is tested at each of the test frequencies. To do this, the bridge input cable is connected directly to the output terminals of the test oscillator. With the toggle switch S1 in the "Adjust" position and the test oscillator and frequency selector switch set at the proper test frequency, the output of the test oscillator and the gain control (R2) are adjusted to give full scale deflection of the distortion meter. Then, when S1 is thrown to the "Read" position, the meter reading should drop to a very low value. To minimize the reading, the null resistor (R1) and the test oscillator frequency must be varied simultaneously. If the null bridge is functioning properly, the adjusted null at some frequency near the desired test frequency will be quite sharp and the meter reading will be very nearly zero.

If an incomplete null is obtained, the bridge components are faulty or

the test oscillator has some harmonic output which is being indicated on the meter. The nature of this residual reading can be readily determined by the use of the search oscillator. With the distortion meter operating as above in the "Read" position, the search oscillator is connected to the audio transformer input leads and enough search signal is injected to about double the residual reading on the meter. The frequency range of the test signal and its harmonics is then explored by varying the frequency dial of the search oscillator slowly. If there is a large beat fluctuation of the meter pointer at the fundamental frequency and little at its multiples, the residual reading is caused by imperfect bridge balance. If the converse is true, the harmonic content of the test oscillator is to blame for the incomplete null. The harmonic output of the test oscillator should be carefully recorded so that it can be discounted when actual amplifier tests are being made.

In using the bridge to analyze the distortion introduced by an amplifier, the procedure followed is the same as that used above for determining the distortion content of the oscillator except that the amplifier is introduced between the test oscillator and the bridge, as shown in Fig. 3. The bridge input leads are connected directly across the speaker voice coil or other normal amplifier load. The gain of the amplifier is set to the value at which it is desired to determine the distortion. The null reading is then obtained as above and, expressed as a percentage of the full scale reading of the meter minus the residual reading, is the total distortion percentage introduced by the amplifier. The harmonic components may then be individually identified by the use of the search oscillator. Each beat noted indicated a component of that frequency (read from the search oscillator) and relative magnitude present in the output of the amplifier.



# SECTION V

## METERS AND MEASUREMENTS

### The Direct-Current Meter

ALTHOUGH the d.c. meter is a standard tool around the laboratory, service bench or "ham shack," its usefulness may be greatly enhanced by a better understanding of the principles underlying its construction and applications. Despite the fact that the judicious use of electrical instruments is an unfailing hallmark of the skilled electronics technician, there is a tendency on the part of many to accept the meter at its face value without ever gaining an intimate knowledge of its internal functioning. Actually, a complete familiarity with the capabilities and limitations of the d.c. meter can be gained only through a study of its electrical and mechanical characteristics. We will presently discuss these characteristics and point out certain precautions to be observed in the use of such measuring instruments. Because the moving-coil permanent-magnet type known as the D'Arsonval meter forms the basis of about 90% of the meters in common use, being used to measure current, voltage and resistance with different auxiliary circuitry, the present discussion will be restricted to this type.

#### The D'Arsonval Movement

The fundamental principle of all general types of electrical meters is the same; the electrical quantity to be measured is converted into a mechanical motion which is calibrated in terms of that electrical quantity by means of a scale and pointer. In the D'Arsonval type, direct current flowing in the turns of a coil suspended in a steady magnetic field produces an electromotive force which rotates the armature against the counter-torque of a hair—by an amount proportional to the current flowing. A light attached to the armature indicates the rotation of the coil, and

therefore the current value, on a semi-circular calibrated scale. Figure 1 illustrates the usual form of this arrangement. The current-carrying coil is wound on a light-weight frame or armature which, in turn, is supported between sapphire-jewelled pivot bearings which allow it to rotate freely. The electrical connections to the coil are made through spiral hair-springs at each end of the armature. These fine alloy springs perform several vital functions. Besides providing the current-carrying path between the armature and the stationary parts of the meter, they provide the counter-force against which the meter torque or rotational force acts, as well as supplying the restorative force which returns the pointer to zero when current ceases to flow. The coil thus mounted is immersed in a strong magnetic field which is usually provided by a permanent magnet. The stability and permanency of this magnet are of importance, as well as the uniformity of the magnetic field pro-

duced between its poles. The pole tips are usually semicircular in shape to fit closely around the moving coil. The uniformity of field is greatly improved by the use of a cylindrical core of soft iron mounted in the center of the armature so that the moving coil revolves around it. The indicating pointer is affixed to the armature at one end and a system of small adjustable counterweights is used on the tail-piece and cross arm of the pointer to balance the complete armature assembly. The angular movement of the moving coil assembly is restricted by a set of cushioned stops.

The completed assembly is extremely delicate and precise. It is interesting to note that most of the components serve several purposes. For instance, the armature frame not only provides the form upon which the current-carrying coil is supported, but is also a closed-loop conductor in which eddy currents are induced which oppose the motion of the armature and so provide *damping* of the meter movement. Excessive over-swung or oscillation of the pointer is thus avoided.

#### The Current Meter

Essentially, the D'Arsonval meter is a current measuring device. The flow of current through the moving coil sets up a magnetic field around the coil which interacts with the fixed field produced by the permanent magnet to cause rotation of the coil. The turning torque developed is proportional to the strength of the permanent magnet. The number of turns in the coil, and the amount of current flowing in the coil. The pointer deflection which results is determined by the strength or counter-torque of the spiral springs. At any given meter deflection, the torque produced

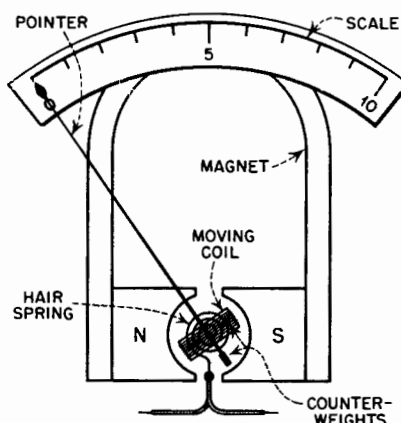

ESSENTIAL PARTS OF D.C. METER  
FIG. 1

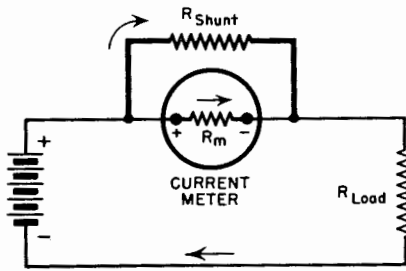

$$R_{\text{Shunt}} = \frac{R_m}{(N-1)}$$

$R_m$  = Internal meter resistance.  
 $N$  = Desired scale multiplying factor.

USE OF SHUNT RESISTANCE  
 TO EXTEND CURRENT-METER RANGE  
 FIG. 2

by the interaction of the current in the coil and the magnetic field is exactly equal to the counter-torque of the hair springs and an equilibrium results. Since in any given meter design the current in the coil is the only variable, the deflection of the pointer is directly proportional to the amount of current flowing. The scale graduations in properly designed d.c. meters of this type are therefore linear.

The amount of direct current required to deflect the pointer to the highest graduation on the scale is called the *full scale sensitivity* of the meter. Instruments are manufactured in a wide range of sensitivities ranging from amperes down to a practical limit of about 20 microamperes. In addition to the above, high-sensitivity instruments are available with sensitivities of 1/2 microamperes for full scale deflection. Such high sensitivities are achieved by the use of powerful permanent magnets, lightweight multi-turn coils, and very delicate hair-springs.

Meters having sensitivities of one milliamperes or less may be used for measuring any larger value of current by the proper use of *shunts*. If a conductor having a resistance equal to

the internal resistance of the meter is connected in parallel with it, the current will divide equally between the two paths and hence twice as much current will be required to give full-scale deflection of the meter. If a shunt is chosen which has one-fourth the resistance of the meter coil, the currents through the parallel resistances divide in the ratio of 4 to 1, and since only *one-fifth* of the total current flows through the meter, its full-scale indication is multiplied by a factor of *five*. Figure 2 shows the connection of a shunt to a direct-current meter and the equation commonly used to determine the shunt resistance required to extend the scale by a factor  $N$ . The internal resistance of the meter may be determined from the published characteristics of that type, or by measurement. In multi-range instruments it is usual to select shunts which multiply the scale calibration by multiples of ten for ease in reading.

#### The D. C. Voltmeter

The same basic movement which is used to measure direct current is also employed in voltmeters. In this case, resistance is added in *series* with the meter in the manner shown in Fig. 3. Such external *multiplier resistors* may be used with a high sensitivity milliammeter or microammeter to measure voltages ranging from millivolts to kilovolts. The meter is still performing its original function as a current measuring instrument, but in this case it is measuring the current which an unknown voltage causes to flow in a known resistance. The voltage is therefore determined by Ohm's Law ( $E=IR$ ) and the meter scale may be calibrated directly in terms of voltage. Meters for voltmeter applications are classified according to "ohms-per-volt" ratings, i.e., the number of ohms which must be contained in the voltmeter circuit for each volt which the meter is to indicate. For example, to limit a voltmeter using a one-milliamperes basic movement to full scale deflection when 10 volts is impressed, the total resistance of the circuit must equal 10,000 ohms, by Ohm's Law. A total of 15,000 ohms would be required for 15 volts full scale, etc. Thus a .001 ampere meter one milliamperes full scale is rated at "1000 ohms-per-volt". The same meter can be made to read 500 volts full scale by using a 500,000 ohm multiplier in series with it. In such cases, where the required multiplier resistance is very large compared with the internal meter resistance, the latter is usually ignored since the error introduced is much less than the reading accuracy of the meter. However, if it

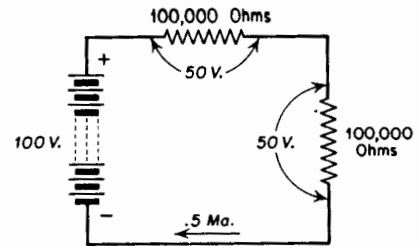

UNDISTURBED CIRCUIT CONDITIONS

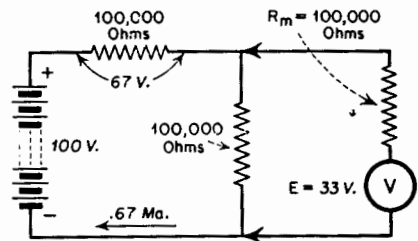

CIRCUIT "LOADED" BY VOLTMETER  
 FIG. 4

were desired to make a 1000 ohms-per-volt meter read 1 volt full scale, it would be necessary to include the meter resistance in the total value of 1000 ohms required. If the internal resistance of the meter is 100 ohms, the correct value of the multiplier would be 900 ohms since a 10% error would be introduced if the meter resistance were neglected.

Since the voltmeter is always connected across the voltage drop being measured, it is important to use an instrument having a total resistance which is large compared to the circuit to which it is connected. Otherwise, serious inaccuracies result since a low resistance meter "loads" the circuit being measured so that the voltage drops indicated are not those which exist in the undisturbed circuit. A simplified example of such misuse of the voltmeter is illustrated in Fig. 4. To reduce such errors, basic meters having full-scale sensitivities of 50 microamperes (20,000 ohms-volt) or 100 microamperes (10,000 ohms volt) are used in high quality voltmeters.

#### The Ohmmeter

Just as the D'Arsonval current meter is used to determine voltage when the current and resistance are known, it may be used equally well to read resistance by indicating the current which flows when a known voltage is impressed across an unknown value of resistance.

Such an instrument, calibrated directly in ohms, is called an "ohmmeter" and is widely used in a variety of circuit types of which Fig. 5 is a typical example. In this circuit, a

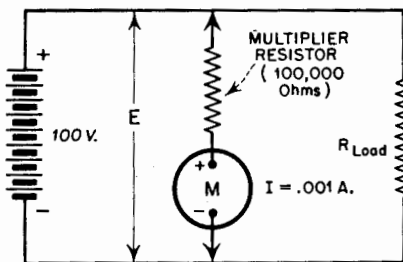

$$E = IR = 100 \text{ Volts}$$

USE OF D.C. METER  
 AS VOLTMETER

FIG. 3

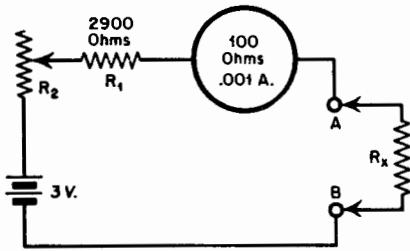

$$R_x = R_c \left( \frac{I_s - I_x}{I_x} \right)$$

Where:

$R_x$  = Unknown resistance.

$R_c$  = Circuit resistance (A and B shorted).

$I_s$  = Meter current (A and B shorted).

$I_x$  = Meter current ( $R_x$  in circuit).

TYPICAL OHMMETER CIRCUIT  
FIG. 5

battery or other source of voltage is provided which is capable of producing a full-scale deflection on the meter when the test terminals (A and B in Fig. 5) are shorted. Variations in battery voltage and other circuit constants are compensated for by adjustment of a reostat ( $R_2$ ). If an unknown resistance is inserted between the test terminals, the meter deflection will be reduced proportionately. The meter scale can, therefore, be calibrated directly in terms of the external resistance required to limit the meter current to that value. When the unknown resistance is equal to the internal resistance of the ohmmeter circuit, the meter will read half-scale. The formula used for the calibration of this simple ohmmeter type is also shown in Fig. 5. For the measurement of extremely low or high value of resistance, more complex ohmmeter circuits are employed.

#### Meter Accuracy

Direct current meters are supplied in many degrees of accuracy according to the requirements of the application. Such applications vary extremely from meters for use as primary laboratory standards having rated accuracies of .1 of 1 percent to mere indicators of the presence or absence of electricity.

Meters rated at better than 1% accuracy fall into the "precision laboratory" category and should be used only in protected, "well behaved" circuits requiring such high accuracy. They are usually of the "portable" type which are used with the needle in a horizontal position for greater accuracy and have mirror-scales to reduce *parallax* errors in reading.

In the accuracy range below 1% are the great majority of "general utility" or "panel" meters which are the "work horses" of the electrical instrument family. They are usually mounted in test equipment panels and switchboards in a vertical position. The average accuracy of this class of meters is about 2%.

The accuracy rating of all d.c. meter types is usually given in terms of the percentage of full-scale reading to which the meter is guaranteed. A single range meter reading 100 volts full scale and rated at 1% accuracy would thus read within 1 volt of the correct value at any deflection. At 10 volts this meter could, therefore, be in error by as much as 1 volt, or 10%. Good engineering practice dictates that meters be used at a minimum of one-third full-scale deflection for this and other reasons.

#### Factors Effecting Meter Accuracy

The manufacturer's nominal accuracy rating does not insure accurate results from a meter in the hands of an inexperienced technician or an instrument which has been subjected to abuse. The following tabulates some of the mechanical and operational factors which may cause large errors in the reading of d.c. meters of the D'Arsonval type:

(a) **Stray Magnetic Field Errors.** Since the deflection of the meter depends on the strength of the permanent magnet, serious errors may be introduced by stray magnetic fields from other meters, current carrying conductors, magnets and other ferrous materials. Expensive meters are usually provided with adequate magnetic shielding. Some errors are also caused by mounting small meters in heavy steel panels. Meters especially calibrated for such mounting are usually so marked.

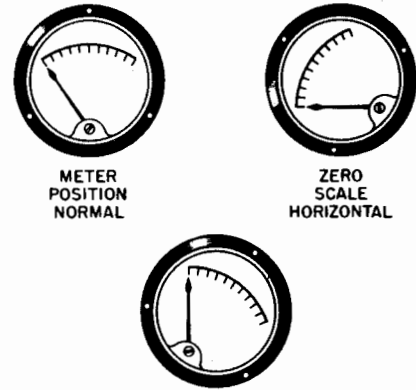

TEST FOR MOVEMENT BALANCE

FIG. 6

(b) **Balance Errors.** The delicate system of counterweights which balance the moving-coil assembly may cause "zeroing" or reading errors if improperly adjusted. The balance of the movement may be checked by holding the meter in the three positions shown in Fig. 6. If the pointer does not indicate zero in each position, the movement is not perfectly balanced. Unbalance is most serious in vertical mounted meters.

(c) **Overload Errors.** Permanent damage or burn-out may be caused by repeated or heavy overloads of the meter movement. Excessive current through moving-coil types causes heating of the coil and springs. Heating of the latter results in "annealing" or loss of spring tension which impairs accuracy. Overloads also cause needle "banging" which may damage pointer or pivots.

(d) **Sticky Movement Errors.** The meter movement may be prevented from moving freely by several mechanical defects. Chief among these is chipped jewels or damaged pivots due to rough handling. Sticking may be manifest in the failure of the meter to reproduce a known reading when approached from values above and below the known value. Light tapping of the meter case is frequently resorted to as a cure. Meter sticking is also caused by small magnetic particles which may be gathered by the magnet of a meter which is removed from its case and left unprotected.

## High-Resistance Non-Electronic D. C. Voltmeters

A VOLTmeter used to check high-resistance electronic circuits must have high internal resistance,

in order to minimize circuit loading. The d. c. vacuum-tube voltmeter meets this requirement and has been

obtainable in the service category for about 15 years. Most of these electronic voltmeters have input re-



U. H. R. Voltmeter Circuits

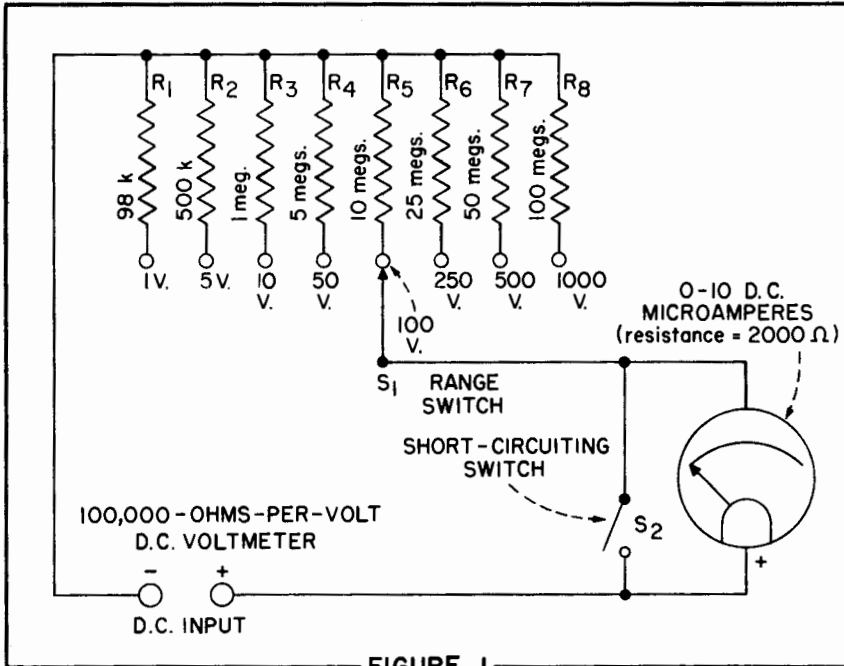

FIGURE 1

Figure 1 shows the circuit of a multi-range ultra-high-resistance d. c. voltmeter having 100,000 ohms per volt sensitivity. A 0-10 d. c. microammeter is employed. The voltage ranges provided are 0-1, 0-5, 0-10, 0-50, 0-100, 0-250, 0-500, and 0-1000 volts. Other ranges, more desirable to the reader can be added or substituted for those shown. The multiplier resistor values are calculated by means of Ohm's Law,  $R = E/I$  where R is the required multiplier resistance in ohms, E is the desired full-scale voltage deflection in volts, and I is the full-scale current deflection of the microammeter in amperes. Figure 4 is a chart listing calculated multiplier resistance values for 23 common voltage ranges for use with sensitive microammeters of six different full-scale deflections.

The internal resistance ( $r_m$ ) of high-sensitivity microammeters is comparatively high. In the 0-10 microammeter, for example, this value lies between 2000 and 4000 ohms, depending upon manufacture and model number. For best accuracy, the meter resistance value,  $r_m$  must be subtracted from the calculated multiplier resistance, R, whenever  $R/r$  is 100 or less. Thus in Figure 1, the calculated value of the 1-volt multiplier would be 100,000 ohms. But the meter internal resistance is 2000 ohms and  $100,000/2000 = 50$ , so we must subtract the meter resistance, giving the accurate multiplier value of 98,000 ohms. On each other voltage range,  $R/r_m$  is higher than 100, so the calculated multiplier resistance values are used.

Figure 2 is a table showing pertinent data for commercially available sensitive d. c. microammeters with full-scale deflections between 2 and 30 microamperes. Displayed in this chart are the internal resistance ( $r_m$ ) values and the voltmeter sensitivities (in ohms per volt) which the meters will provide in voltmeter circuits. All except the 2 microampere model are panel-type instruments. The 0-2 microammeter is a portable case-type, but can be mounted on the panel of an assembled u. h. r. voltmeter.

Figure 3 shows a useful variation of the u. h. r. volt-meter circuit. Here, a center-zero type of microammeter is employed. The right half of the scale is graduated from zero up to the maximum positive voltage, and the left half from zero down to the maximum negative voltage of the same value. When a test voltage is applied so that the upper input terminal is positive, the meter is de-

sistances of 11 megohms, constant for all ranges, although some service-type models go as high as 20 megohms.

The non-electronic d. c. voltmeter offers the advantages of complete portability, simplicity, freedom from drift and zero adjusting, and the ability to operate without any sort of power supply. These features often are definitely required in field testing and are desirable also in the laboratory when removal from power line and batteries is a requisite. But the common non-electronic voltmeter has relatively low input resistance.

It is of interest to note that a non-electronic d. c. voltmeter having high input resistance can be obtained with a sensitive d. c. microammeter and high-resistance multiplier. The full-

scale deflection of the microammeter must be somewhat lower than is common in meters ordinarily used in conventional voltmeters. Thus, a 0-10 d. c. microammeter with a 25-megohm series resistor provides a 0-250 d. c. voltmeter. Note that the input resistance in this case is higher than that of the conventional d. c. vacuum-tube voltmeter. The instrument sensitivity is 100,000 ohms per volt.

Ultra-high-resistance, non-electronic d. c. voltmeters of this type are entirely practical. Multiplier resistors may be switched in the instrument circuit, in the conventional manner, to change ranges. D. C. microammeters are available with full-scale deflections of 2, 5, 10, 15, 20, and 30 microamperes.

SCALE ( $\mu$ a.)	METER RESISTANCE, $r_m$ (ohms)	VOLTMETER SENSITIVITY (ohms per volt)
0-2	10,000	500,000
0-5	8000	200,000
0-10	2000-4000	100,000
0-15	5000	66,666
0-20	1520	50,000
0-30	1520	33,333

TABLE OF MICROAMMETER DATA

FIGURE 2

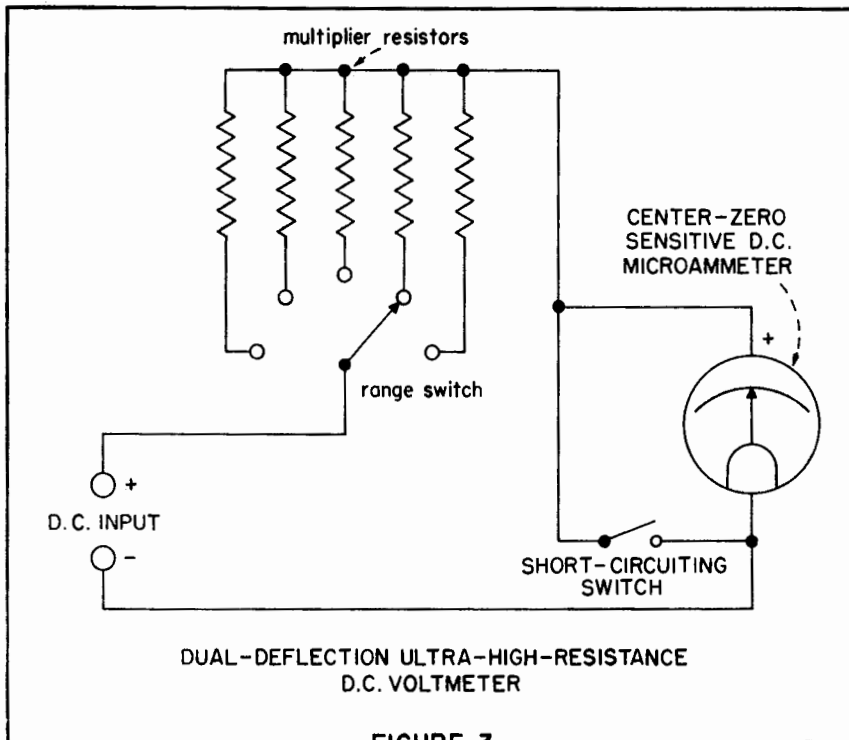

FIGURE 3

deflected up-scale to read the voltage. If the voltage source is reversed, the meter is deflected down-scale and reads the same voltage but with negative sign. Thus, no changeover of test leads is needed.

#### Sensitivity and Resistance

The last column in the chart in Figure 2 shows the voltmeter sensitivity which is afforded by available high-sensitivity microammeters. These sensitivities are obtained on each range of voltmeters employing the meters.

The input resistance changes with each range of the voltmeter, however, since it is equal almost entirely to the resistance value of the multiplier. The multiplier values listed in the chart in Figure 4 show the input resistance which a given voltmeter will have on each range. If we take 10 megohms as the approximate input resistance of a d. c. vacuum-tube voltmeter, we find that this value will be equalled on the 20-volt range using a 0.2 microammeter, the 50-volt range with a 0.5 microammeter, 100-volt range with 0.10 microamperes, 150-volt range with 0.15 microamperes, 200-volt range with 0.20 microamperes, and 300-volt range with 0.30 microamperes. In each instance, all higher-voltage ranges will have higher input resistance than the v. t. voltmeter.

These relationships point up the necessity for using the lowest-range microammeter that can be afforded for this application.

#### Pointers on U. H. R. Voltmeter Construction

The combination of extremely sensitive microammeter and very high multiplier resistance is not commonplace. Certain precautions are necessary in the construction of voltmeters employing this combination, which do not arise in connection with voltmeters up to 20,000 ohms-per-volt sensitivity. These precautions are outlined below.

1. Special instrument-type resistors are required beyond 50 megohms. Be sure that the outer surfaces of these components are cleaned carefully after soldering into place. Try not to touch the surfaces with the bare fingers, to prevent depositing greasy or moist finger prints. After installation, wash the exterior portions of the resistors with carbon tetrachloride or any other solvent recommended by the resistor manufacturer. If the resistors have been coated with a special high-insulation wax, DO NOT TOUCH THE BODIES, and do not use solvent which might dissolve the wax.

2. Use the minimum of heat in soldering the resistors in place. Pro-

vide a protective heat sink by holding the pigtailed with flat-nose pliers while soldering. Continue to grip the leads with the pliers until the soldered joint has cooled completely.

3. The range switch must be provided with excellent insulation to prevent leakage paths. Always use a ceramic-type switch for this application, and do not handle the ceramic insulation any more than necessary during assembly of the voltmeter. After installation, wash the ceramic with carbon tetrachloride or lacquer thinner to remove any contamination.

4. The input terminals of the voltmeter must be insulated from the panel material by ample washers or inserts of high-quality dielectric material, such as polystyrene or ceramic.

5. If a metal panel is used, be sure to specify metal-panel operation when ordering the microammeter.

6. Make an air-tight seal of the instrument case to prevent the entry of dust, grease, and moisture which will tend to create high-resistance leakage paths on the range switch and multiplier resistors.

7. Ascertain from the meter manufacturer whether the microammeter can be used in all positions. If the meter is specified to operate in one position only (such as horizontal), make a practice of using the voltmeter only in that position.

8. Include a short-circuiting switch to short-circuit the microammeter itself when the voltmeter is not in use. Low-range microammeters often are susceptible to fields and transient phenomena, and the short circuit will protect the sensitive movement. Because of the high resistance of the multipliers, no damage will be done if a potential accidentally is applied to the voltmeter input terminals while the shorting switch is closed.

#### Pointers on Use of the Voltmeter

No special technique is required to measure voltages with the ultra-high-resistance meter. Manipulation of the instrument and its care are the same as with lower-resistance non-electronic voltmeters. However, it is appropriate to call attention here to a few precautions which should be observed to protect the meter and insure continued accuracy of the instrument.

1. When uncertainty exists as to the approximate level of a voltage, use the highest voltage scale first. Then, switch down successively to each lower range until deflection is

obtained in the upper portion of the scale.

2. Switch the voltmeter to its highest range during idle periods, and also close the microammeter short-circuiting switch.

3. Always close the short-circuiting switch when the instrument is being transported. This provides efficient damping of the meter and will prevent mechanical damage due to shaking and vibration.

4. Do not expose an ultra-high-resistance voltmeter to magnetic fields, moisture, or corrosive fumes for long periods of time.

5. Keep the panel area around the input terminals scrupulously clean of dust, grease, and moisture.

VOLTAGE RANGE	BASIC METER RANGES					
	0—2 $\mu$ a.	0—5 $\mu$ a.	0—10 $\mu$ a.	0—15 $\mu$ a.	0—20 $\mu$ a.	0—30 $\mu$ a.
0—1	500 K	200 K	100 K	66.67 K	50 K	33.33 K
0—1.5	750 K	300 K	150 K	100 K	75 K	50 K
0—2	1 meg.	400 K	200 K	133.3 K	100 K	66.66 K
0—2.5	1.25 meg.	500 K	250 K	166.7 K	125 K	83.33 K
0—3	1.5 meg.	600 K	300 K	200 K	150 K	100 K
0—5	2.5 megs.	1 meg.	500 K	333.4 K	250 K	166.7 K
0—7.5	3.75 megs.	1.5 meg.	750 K	500 K	375 K	250 K
0—10	5 megs.	2 megs.	1 meg.	666.7 K	500 K	333.3 K
0—15	7.5 megs.	3 megs.	1.5 meg.	1 meg.	750 K	500 K
0—20	10 megs.	4 megs.	2 megs.	1.33 meg.	1 meg.	666.6 K
0—25	12.5 megs.	5 megs.	2.5 megs.	1.67 meg.	1.25 meg.	833.3 K
0—30	15 megs.	6 megs.	3 megs.	2 megs.	1.5 meg.	1 meg.
0—50	25 megs.	10 megs.	5 megs.	3.33 megs.	2.5 megs.	1.66 meg.
0—75	37.5 megs.	15 megs.	7.5 megs.	5 megs.	3.75 megs.	2.5 megs.
0—100	50 megs.	20 megs.	10 megs.	6.67 megs.	5 megs.	3.3 megs.
0—150	75 megs.	30 megs.	15 megs.	10 megs.	7.5 megs.	5 megs.
0—200	100 megs.	40 megs.	20 megs.	13.3 megs.	10 megs.	6.7 megs.
0—250	125 megs.	50 megs.	25 megs.	16.7 megs.	12.5 megs.	8.3 megs.
0—300	150 megs.	60 megs.	30 megs.	20 megs.	15 megs.	10 megs.
0—500	250 megs.	100 megs.	50 megs.	33.3 megs.	25 megs.	16.6 megs.
0—750	375 megs.	150 megs.	75 megs.	50 megs.	37.5 megs.	25 megs.
0—1000	500 megs.	200 megs.	100 megs.	66.7 megs.	50 megs.	33 megs.
0—1500	750 megs.	300 megs.	150 megs.	100 megs.	75 megs.	50 megs.

**TABLE OF MULTIPLIER RESISTANCE VALUES**

— FIGURE 4 —

## Applications Of The Electrometer

**T**HE electrometer is an invaluable instrument in physics and electrical engineering when its potentialities and peculiarities are understood.

It finds use both in research and testing.

In one form or another, the electromechanical type of electrometer

has been used in experimental physics for many years. Its familiar types include quadrant, binant, and fiber. Electrometers differ from elec-

TYPE	MANUFACTURER	Filament Voltage	Filament Current	Plate Voltage	Plate Current	Grid #1 Voltage	Grid #2 Voltage	Grid #1 Current	Grid #2 Current	Plate Resistance	Trans-Conductance
VW41	Victoreen	1.5	0.015	6.0	10	----	1.0	250	$<10^{-8}$	125K	10
FP-54	Genl. Electric	2.5	0.09	6.0	60	4.0	4.0	$10^{-9}$	----	45 K	20 <sup>②</sup>
CK571AX <sup>①</sup>	Raytheon	1.25	0.01	10.5	200	-3.0	----	$2 \times 10^{-7}$	----	----	160
CK5697	Raytheon	0.625	0.02	12	220	-3.0	----	$5 \times 10^{-7}$	----	----	135
CK5889	Raytheon	1.25	0.0075	12	5.0	-20	4.5	$3 \times 10^{-9}$	5.0	$18 \times 10^6$	14
D-96475	Western Electric	1.0	0.27	4.0	85	3.0	4.0	$10^{-9}$		25K	40 <sup>②</sup>
		VOLTS	AMP.	VOLTS	$\mu$ a.	VOLTS	VOLTS	$\mu$ a.	$\mu$ a.	OHMS	$\mu$ MHOS

① Data for triode-connected pentode.  
 ② Microamperes - per - volt.

CHARACTERISTICS OF ELECTROMETER TUBES

FIGURE 1.

troscopes, to which they bear somewhat of a resemblance, in that the electroscopes requires only the potential under test for its deflection, while the electrometer must be supplied with an auxiliary potential as well. The ancient gold-leaf electroscopes and the modern electrostatic voltmeter are examples of the single-potential instrument.

The chief advantage of the electrometer is its extremely high input resistance. This characteristic enables the measurement of small currents. It also permits the measure-

ment of voltages under conditions requiring only the minutest current drain. Small currents, such as the  $10^{-10}$  microampere levels produced in gas ionized by radioactivity, have been measured with electrometers.

Electromechanical electrometers, being delicate instruments, are sensitive to vibration, shock, and to some extent to field effects and to air currents. They accordingly give their best performance in the laboratory under skilled handling. The modern vacuum-tube type of electrometer often can be used in environments

unfavorable to electromechanical types. It utilizes a more rugged d'Arsonval type of indicating meter, instead of the delicate galvanometer, and is adapted readily to field use. Moreover, the vacuum-tube type allows the measurement of current by the steady-deflection method, rather than the rate-of-drift method required by other electrometers.

*Configuration of the V. T. Electrometer*

In principle and in general configuration, the vacuum-tube electro-

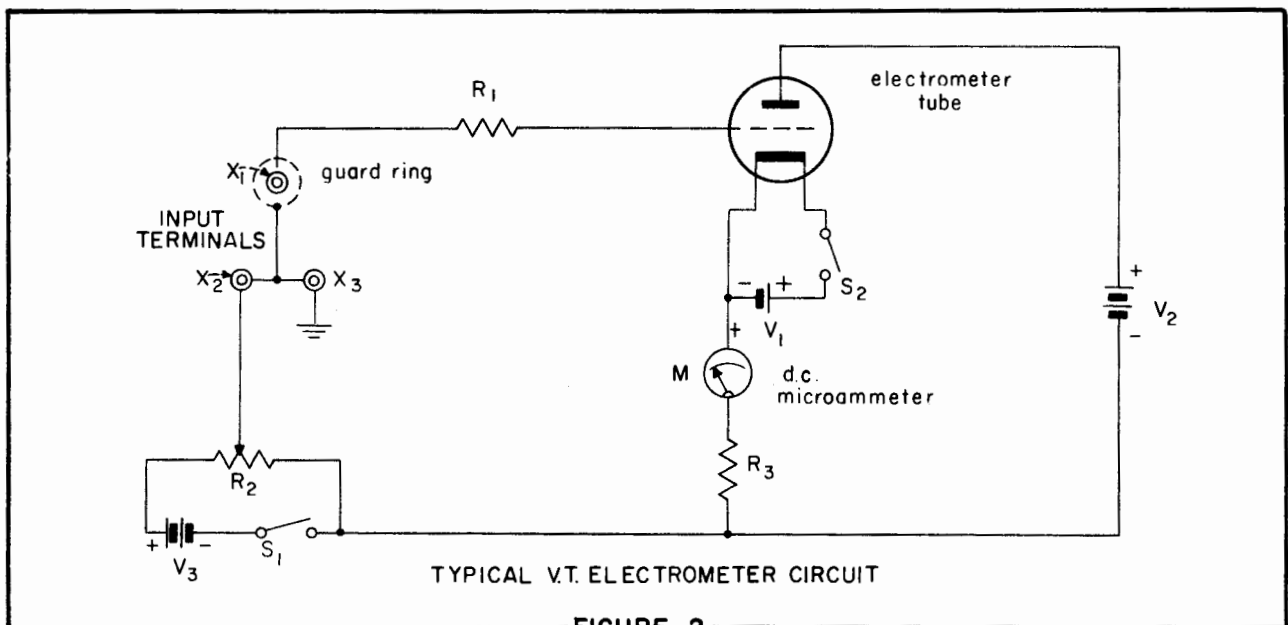
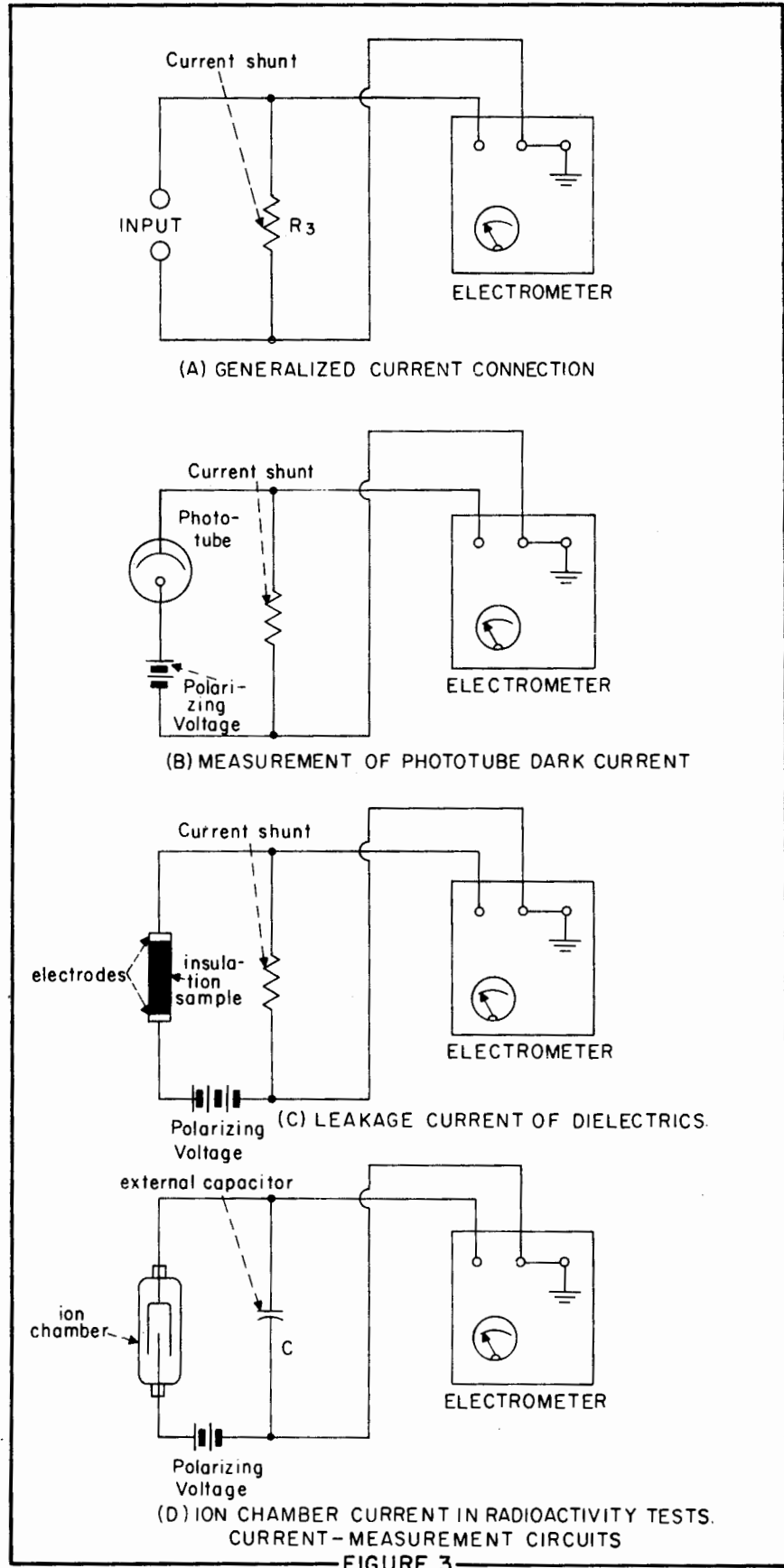

FIGURE 2

meter resembles the well-known d. c. vacuum-tube voltmeter. The main difference is the extremely high input resistance of the former. V. T. voltmeters, for example, have input resistances commonly in the range 10 to 20 megohms. The input resistance of an electrometer can be of the order of  $10^{10}$  megohms.

Figure 2 shows a typical skeleton circuit of a vacuum-tube electrometer. The circuit is battery-operated.  $V_1$  is the filament battery,  $V_2$  plate battery, and  $V_3$  a bucking battery for zero setting. The "high" input terminal,  $X_1$ , is provided with a guard ring. Terminal  $X_2$  may be grounded to  $X_3$  or floated, as test conditions require. The indicating d. c. microammeter is connected in the "cathode" return circuit in series with resistor  $R_3$  which is kept high in value for maximum degeneration. Stability and linearity are enhanced by this degeneration. The instrument is set to zero by means of potentiometer  $R_2$  and the bucking battery,  $V_3$ . Switches  $S_1$  and  $S_2$  disconnect the batteries when the electrometer is not in use. No plate-battery switch is required, since disabling the filament circuit removes plate current.

A standard radio tube would be unsatisfactory in this circuit, since its input (grid-filament) resistance would be too low for electrometer use. Maximum current amplification demands that input resistance be high. Tube insulation usually is good, but internal charges reach the grid, increasing conductance. Special electrometer tubes have good evacuation and operate at low plate voltage to prevent ionization of whatever residual gas is present. They are operated also at low filament voltage and current, and some types are provided with an internal shield grid to isolate the control grid from positive ions from the filament. In some instruments, the second grid is used for the test-voltage input. In the electrometer, the tube is darkened to prevent spurious photoelectric effects, its envelope is washed carefully with a grease-removing solvent, and the outer surface of the envelope



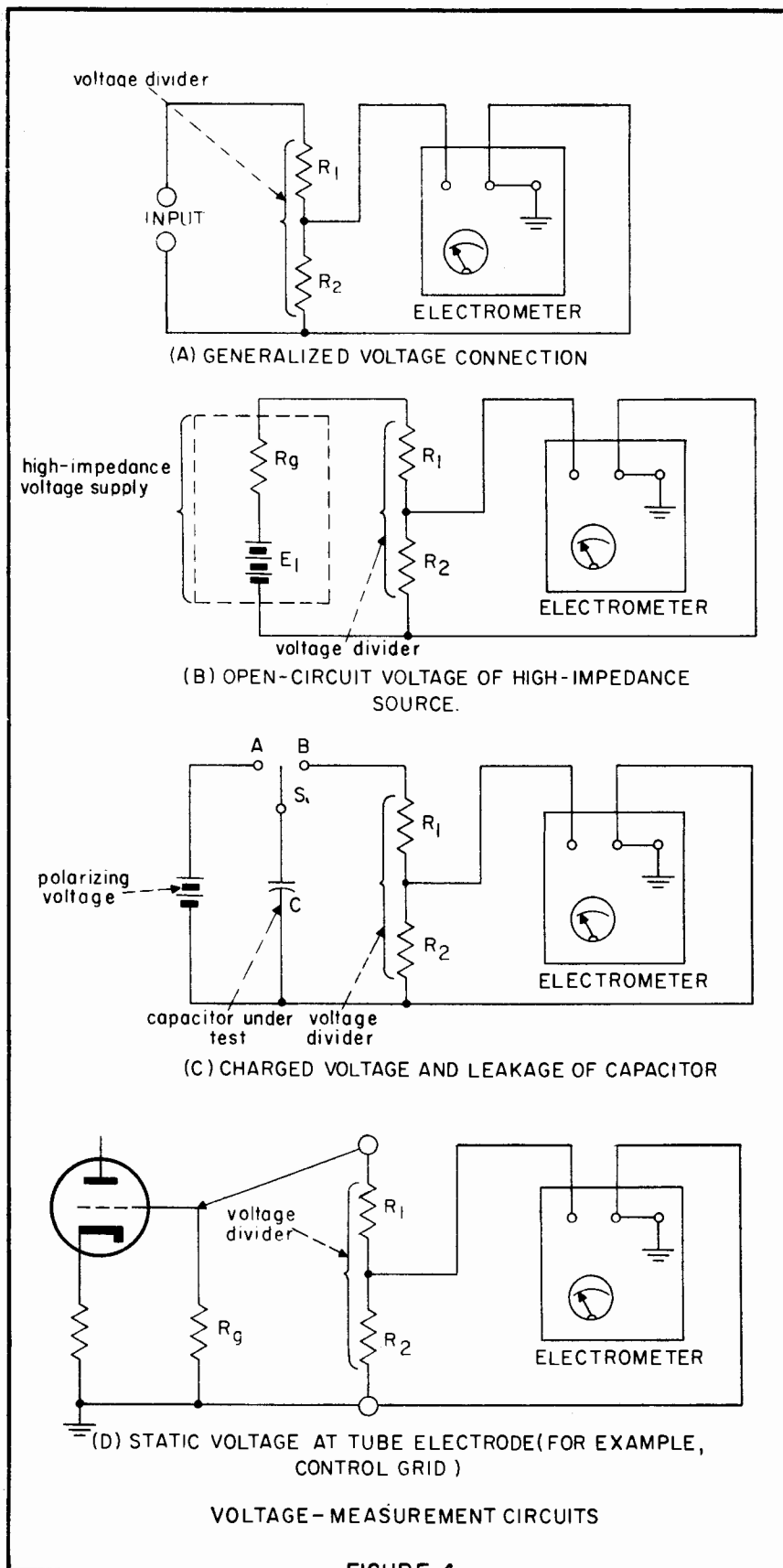

FIGURE 4

may be coated with a high-quality insulating material for additional protection against contamination from accidental touching or from the atmosphere. Figure 1 shows the characteristics of some electrometer tubes.

The electrometer usually is provided with several ranges. Range switching is accomplished by changing simultaneously the values of voltages  $V_1$ ,  $V_2$  (and sometimes  $V_3$ ), and resistor  $R_3$ . A portion of  $R_3$  is made adjustable for range calibration. The scale of meter  $M$  may be calibrated to read directly in volts. Resistor  $R_1$  is a current-limiting component, the purpose of which is to limit tube input current when excessive signal voltages are applied.

Excellent insulation is employed for the input terminals, range switch, zero-set potentiometer, and limiting resistor. These precautions are necessary to prevent a low-resistance shunt of the high input resistance of the tube. Input capacitance of the instrument is very low, being less than 10 uufd. in commercial vacuum-tube electrometers. Because of the high input resistance and the consequent long time constant, this capacitance can retain a charge and cause the meter to remain deflected after a test voltage has been removed from the input terminals. For example, a time constant of 7.5 seconds would be obtained with an electrometer having 7.5 micromicrofarads input capacitance and  $10^{16}$  megohms input resistance.

Because of the low electrometer-tube currents, the plate and filament batteries can be expected to give long life, requiring infrequent replacement and causing little concern if the instrument inadvertently is left switched-on during brief idle periods.

Typical electrometer applications are discussed in the following paragraphs.

#### Current Measurements

An external shunt resistor may be used to convert the electrometer into a current meter in the same manner that such a resistor is used with a

d. c. vacuum-tube voltmeter (See Figure 3A). However, the difference is that the electrometer shunt may have a high resistance value, often many megohms. In this way, the electrometer may be converted into a micro-microammeter. If the scale of the electrometer is graduated in volts, the unknown current value  $I$  (in microamperes)  $= E/R$ , where  $E$  is the electrometer deflection in volts, and  $R$  is the shunt-resistor value in megohms.

Figure 3(B) shows the electrometer and an external shunt conveniently can be used to measure the dark current of a phototube. The tube is supplied with its normal polarizing voltage, and the resulting leakage current sets up a voltage drop across the high-resistance current shunt. This drop then deflects the meter and is converted into current units as explained in the preceding paragraph.

The tiny leakage current of an insulation sample, especially at low test voltages, may be checked with the arrangement shown in Figure 3(C). This circuit is analogous to the preceding one, in that a d. c. test voltage is applied to the sample in series with a high-resistance current shunt. The polarizing voltage will be of whatever value at which the leakage data are required. This arrangement may be employed also for checking the leakage current of high-quality non-electrolytic capacitors, such as mica, ceramic, and first-grade paper types.

The electrometer can be used to check ion-chamber current in radioactivity tests in the manner illustrated by Figure 3(D). The polarizing voltage is applied in the correct polarity to the ion chamber in series with a high-grade capacitor,  $C$ , of accurately-known capacitance. Radiation causes ion charges to be stored by capacitor  $C$ . The electrometer voltage deflection,  $E$ , then is proportional to the radiation ( $Q = CE$ ).

Other current measurement applications of the electrometer include

checking of (1) vacuum-tube grid current, (2) low-order currents in dimly-illuminated photocells and phototubes, and (3) surface leakage on insulators.

#### Voltage Measurements

D. C. potentials at high resistance are checked readily with the electrometer in many circuits in which the comparatively high resistance of a vacuum-tube voltmeter is unsatisfactorily low. When the test voltage exceeds the maximum deflection provided by the electrometer range switching, an external high-resistance voltage divider ( $R_1, R_2$ ) may be used, as shown in Figure 4. The unknown voltage,  $E_1$ , then will be equal to  $(E_2 R_1 R_2)/R_2$ , where  $E_2$  is the elec-

trometer deflection in volts, and  $R_1$  and  $R_2$  (the voltage-divider resistance arms) are in ohms or megohms each.

Figure 4(B) illustrates measurement of the open-circuit voltage of a d. c. power supply having high internal resistance,  $R_G$ . The accurate measurement of such a terminal voltage (a resistor-limited constant-current transistor bias supply is an example) would pose a problem if only a v. t. voltmeter were available, since the internal resistance  $R_G$  would form a voltage divider with the voltmeter input resistance.

The arrangement in Figure 4(C) enables the measurement of the charged voltage and leakage rate of a sample capacitor,  $C$ .  $R_1$  and  $R_2$ , if

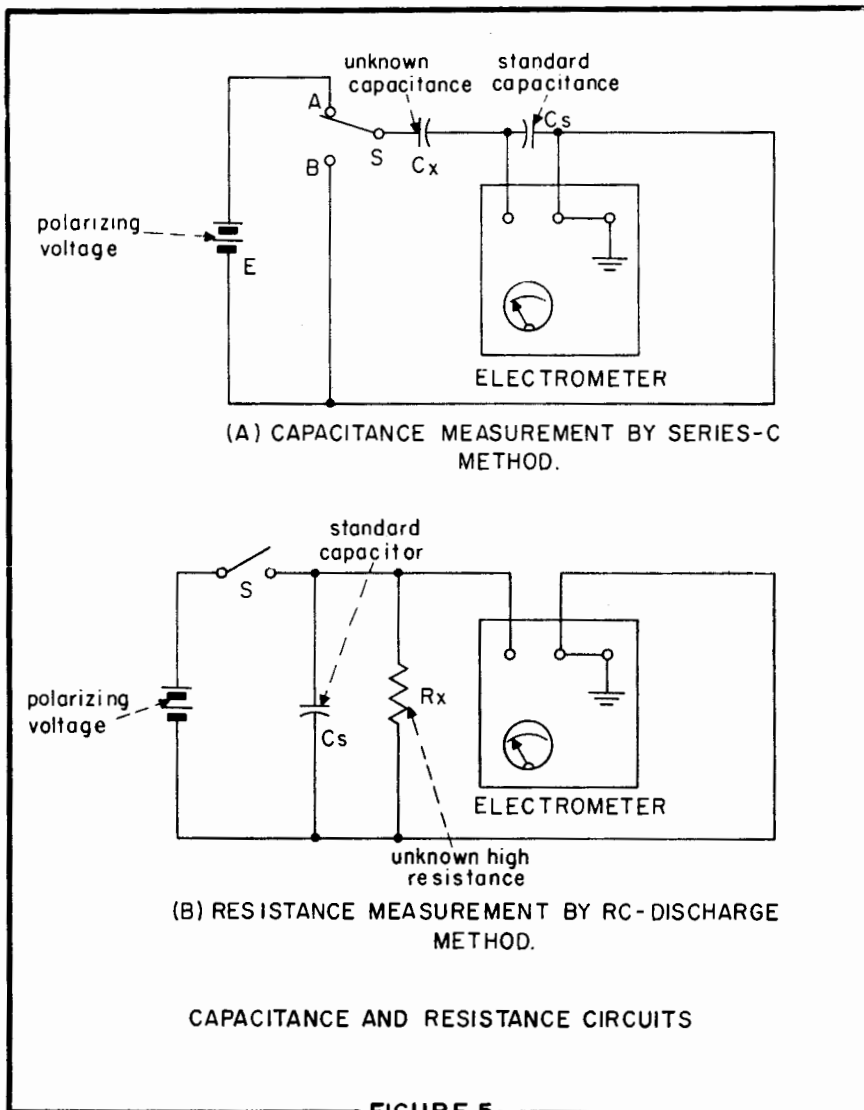

required, are chosen in value so that their total resistance is much higher than the leakage resistance of the capacitor. Switch S is thrown first to position A. This connects the capacitor across the polarizing-voltage source and charges it. The switch then is thrown to position B, connecting the charged capacitor to the electrometer through the voltage divider. The initial deflection of the electrometer shows the charged voltage of the capacitor, and the decline of this reading with respect to time indicates the discharge of the capacitor. This type of test perhaps is more indicative and valid when the external voltage divider ( $R_1$ ,  $R_2$ ) can be omitted. Then capacitor C looks into the very high resistance of the electrometer.

The static potential at a vacuum-tube electrode in series with a high resistance is measured accurately with the electrometer. The control grid is an example. Figure 4(D)

shows the connections for checking static grid potential across a high value of grid resistance,  $R_g$ .

Other applications involving the use of an electrometer to measure potentials include checking of (1) piezoelectric crystal voltage, (2) output of slightly-heated thermocouples, (3) contact potentials, (4) static electricity, and (5) physiological potentials in biological and medical research.

#### Capacitance and Resistance Measurements

The high input resistance of the electrometer permits determination of capacitance by d. c. methods. Figure 5(A) is an example. Here,  $C_s$  is a high-grade standard capacitor of accurately-known capacitance and excellent leakage characteristics. The polarizing voltage, E, also is known accurately. The capacitor shunts the electrometer input terminals. Capacitor  $C_x$  is the unknown unit. Capacitance is determined in terms of

charge division between the standard and unknown. With switch S in position A, the capacitors charge in series. The voltage reading, e, of the electrometer is noted. The unknown capacitance  $C_x = (C_s e)/(E - e)$ .

High resistance values may be determined from the measured time constant of a circuit containing the resistance ( $R_x$ ) and a charged capacitor ( $C_s$ ) of accurately-known capacitance, as shown in Figure 5(B). When switch S is closed, capacitor  $C_s$  is charged to the potential of the polarizing voltage, and this value is indicated by the electrometer. When the switch is opened, the capacitor begins to discharge through  $R_x$ . The discharge rate then is accurately timed up to the point at which the electrometer voltage deflection has fallen to 37% of its initial value. The unknown resistance  $R_x$  (in megohms) =  $t/C_s$ , where t is the discharge time (in seconds) and  $C_s$  the standard capacitance (in microfarads).

## Testing Semiconductor Diodes

**T**HERE seems to be a growing impression that semiconductor diodes can be tested adequately with an ohmmeter. This results from the fact that a d-c ohmmeter will show a difference between the forward and reverse resistances of a diode or rectifier if its leads are swapped back and forth.

The unsuitability of the ohmmeter test as a sole check method lies in the fact that the meter voltage and current often bear no significant relationship to the rated d-c parameters of the diode. Thus, a diode may be checked as good at the ohmmeter voltage and still be unsatisfactory at the rated voltage, and vice versa. Also, it very often is difficult to determine by this method the actual front-to-back resistance ratio of a diode; since the ohmmeter must be operated on at least two different ranges in order to read the values accurately, and switching the ranges not only changes the applied voltage but also the value of series resistance introduced by the instrument. The consequent variations in applied voltage

and load resistance change the operating point along the diode characteristic curve, *separate* diodes also have the same effect, and the readings are meaningless unless all factors and conditions are known.

Another important consideration is that a diode might check satisfactorily in a d-c test, ohmmeter-type or otherwise, yet not be suitable for an intended application as an a-c or r-f rectifier or demodulator.

Use of the ohmmeter therefore is restricted to the simplest sort of initial test for separating good diodes from bad, since all that this instrument indicates reliably is that the component under test is a rectifier.

#### Types of Tests

Two types of tests may be applied to semiconductor rectifiers, whether crystal diodes or power rectifiers. These are identified broadly as d-c tests and a-c tests. There can be several categories in each type.

Basically, the d-c test consists of passing a specified amount of current through the diode and checking

the resulting d-c voltage drop across the diode. The test is made separately, with the proper polarities, for forward and reverse conduction through the diode. Note that this is the opposite of testing tube-type rectifiers, where the procedure is to apply a specified voltage and measure the resulting current. The d-c test may be made at a multiplicity of points and a continuous static curve plotted from data taken at these points. A short test consists of data taken at single forward and reverse check points specified by the diode manufacturer.

A-c tests fall roughly into two groups: (1) the *rectifier test* involves applying a given sinusoidal a-c voltage to the diode and measuring the resulting d-c output current, and (2) the *a-m detector test* in which an amplitude-modulated sinusoidal voltage is applied to the diode in series with an appropriate load resistance, bypassed at the carrier frequency, and the resulting modulation-frequency voltage measured across the load resistance.



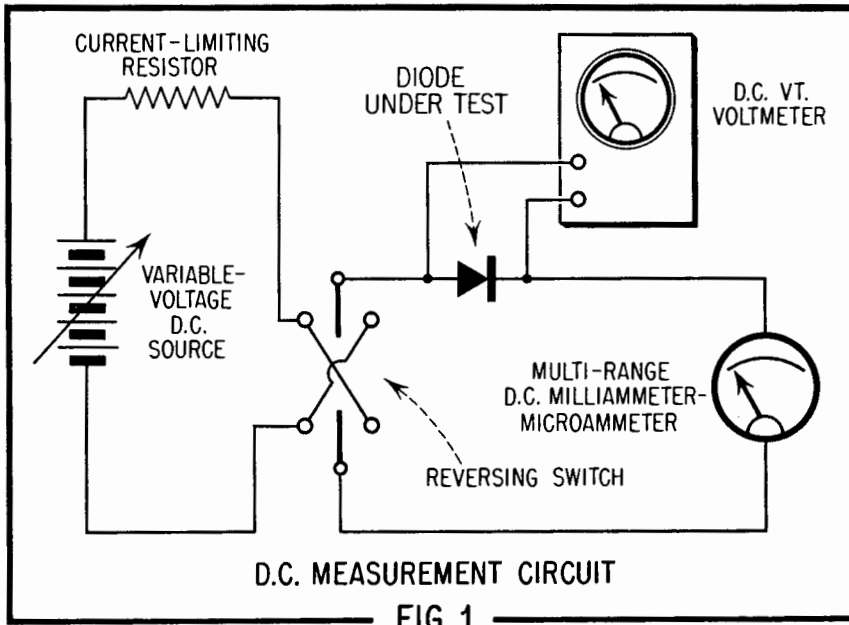

FIG. 1

Other special tests for certain diodes of specific types or for those intended for special-purpose applications will be described later.

As to which type of test is the most suitable, there is general agreement among semiconductor engineers that a diode should be tested under the conditions that more closely approximate its intended methods of operation. This does not necessarily mean that a diode which is to be used, for example, as a video detector must be tested in the actual tv receiver circuit (although that is not ridiculous). But such a diode should be given an r-f, instead of d-c test. Likewise, a diode which is to be used as a meter rectifier should be given a low-frequency a-c test. Conversely, a diode which is to be used in a direct-current application, for example as a polarity-sensitive element in series with a relay coil, should be checked at the direct current level at which it must operate. Very little significant information could be gained from a d-c test regarding the r-f performance of a diode, nor could the r-f test reveal what might be expected in the way of d-c performance.

**D-C Tests**

**Characteristic Curve.** Figure 1 shows the apparatus setup for d-c measurements. The variable-voltage d-c source may be either a battery or a line-operated power supply. The reversing switch allows changeover of the d-c supply polarity. The voltmeter and current meter also must have reversing switches, although not shown in the schematic.

First, with the anode of the diode under test biased positively for forward conduction, the current is adjusted to several levels within the safe operating range of the diode, starting at zero, by varying the voltage. The current and voltage variations then are recorded. Next, the reversing switches are thrown to bias the anode negatively for reverse (back) conduction and the procedure repeated. The maximum diode voltages, both forward and reverse, and the maximum currents must not exceed the maximum *continuous* operating values given by the diode manufacturer. The current and voltage data so obtained may be used to plot a static curve of the type shown

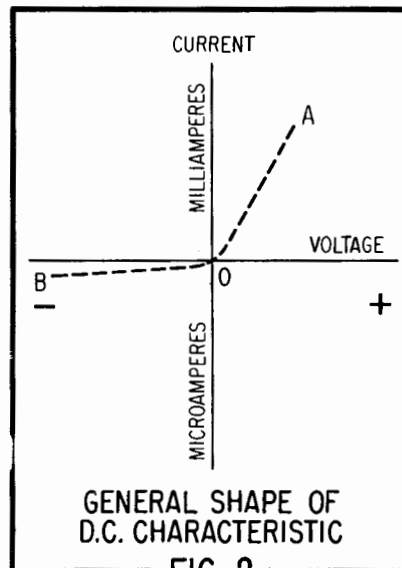

FIG. 2

in Figure 2. The forward conduction characteristic extends from O to A, and the reverse conduction characteristic from O to B. Positive voltage values are low; negative values high.

For small diodes, forward current is expressed in milliamperes and reverse current in microamperes; while for power rectifiers, forward current is in amperes and reverse current in milliamperes.

Figure 2 shows the *general* shape of a diode static characteristic. Various diode types show some departure, one way or the other, from this curve. In gold-bonded germanium diodes, for example, section OA is steeper than in point-contact types. In germanium power rectifiers, OA is quite steep and OB moderately steep. The selenium rectifier curve has slopes which are intermediate between the preceding types. The silicon junction diode is a special case, its curve showing a characteristic such as Figure 3. The forward current rises sharply at a particular value of positive anode voltage, and the reverse current similarly increases sharply at a particular reverse potential, called the Zener voltage.

The static characteristic curve is helpful when information is desired regarding behavior of the diode throughout its operating range. Obtaining such a curve by the point-by-point d-c method, however, is laborious.

**Single-Point D-C Test.** In many requirements for a diode acceptance test, a complete characteristic curve is not needed. In these cases, a sin-

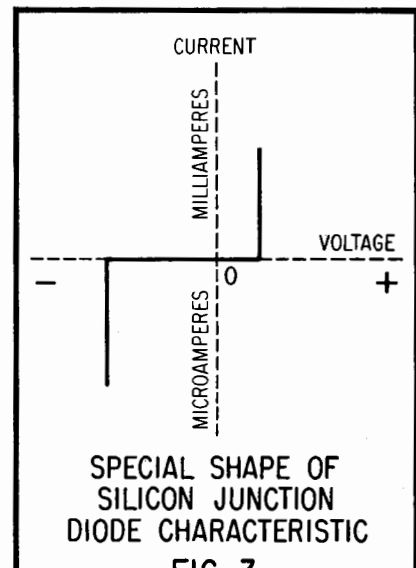

FIG. 3

gle forward check and single reverse check will suffice.

The same apparatus setup shown in Figure 1, or a simplification of it, is used but spot voltages and currents are employed. Most small diodes may be checked at +1 volt and -10 volts. When these diodes are to be used for blocking high reverse bias voltages, they usually are checked at -50 v or -100v, depending upon type.

**Observations in D-C Tests.** The main objective of the d-c test is to determine whether the diode complies with current and voltage specifications. While under test, however, observations may be made of other important features which might render the diode unsatisfactory. These include current or voltage flutter current or voltage drift, heating, and intermittents.

#### A-C Tests

**Rectification.** In this test, an a-c voltage of required frequency and amplitude is applied to the diode or rectifier, and the resulting d-c output current measured. Figure 4 shows the test setup.

By means of the Variac, the applied a-c voltage, as indicated by the voltmeter, is adjusted to the rated operating voltage of the diode. The output current is read from the current meter. The latter will be a d-c milliammeter for small germanium, selenium, and silicon diodes and an ammeter for power-type germanium, selenium, silicon, copper oxide, and magnesium-copper sulphide rectifiers.

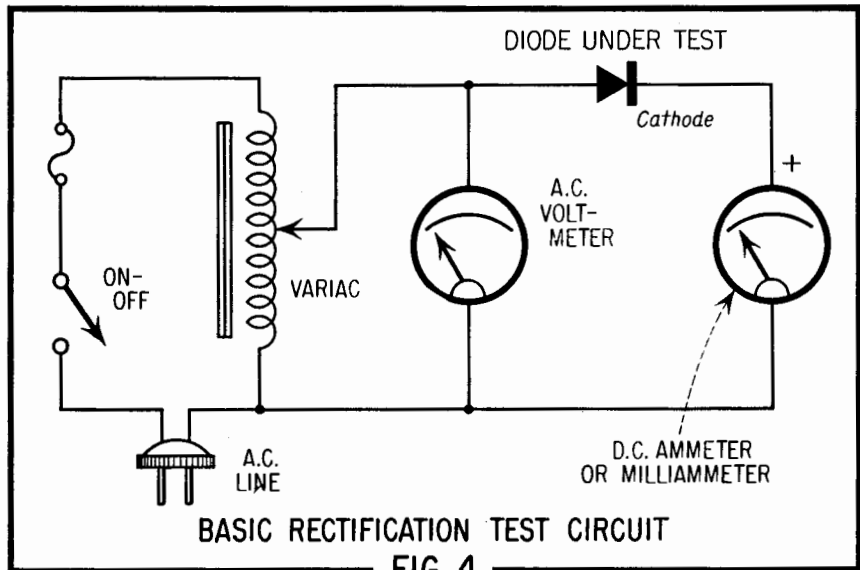

FIG. 4

At frequencies other than that of the a-c power line, the Variac must be one designed to handle the operating frequency. At high audio, and radio frequencies, a suitable adjustable-output signal generator may be substituted for the power line and Variac. The generator output impedance must be low. At high frequencies, a v-t voltmeter is needed to measure the applied voltage.

In the rectification test, the d-c output current is noted when the applied voltage is the operating value specified by the diode or rectifier manufacturer. The test is repeated at several values of recommended load resistance.

**Rectification Efficiency.** The ability of a diode to function satisfactorily as a rectifier may be evaluated in terms of the ratio of its d-c output voltage to an applied a-c voltage. This ratio is termed *rectification efficiency*.

Rectification efficiency often is specified in critical applications of germanium and silicon diodes in communications and instrumentation equipment. Figure 5 shows the apparatus setup for measuring this factor.

The test signal is supplied by a suitable adjustable-output signal generator through an isolating transformer, T. The output winding of this transformer has both low impedance and low d-c resistance with respect to the diode forward resistance.

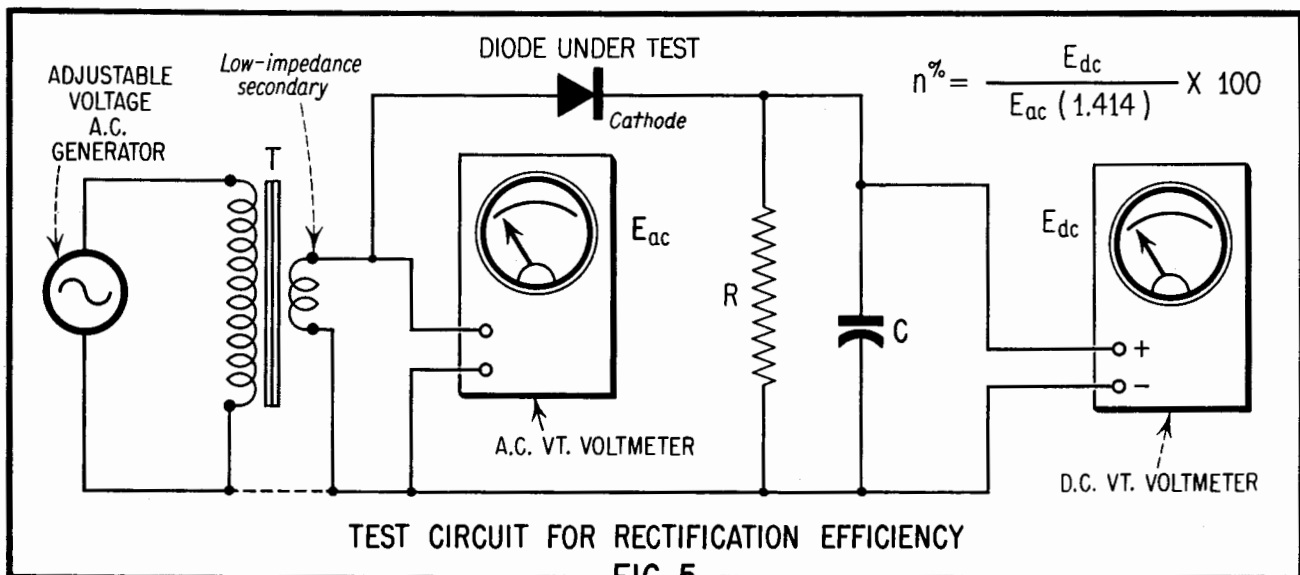

FIG. 5

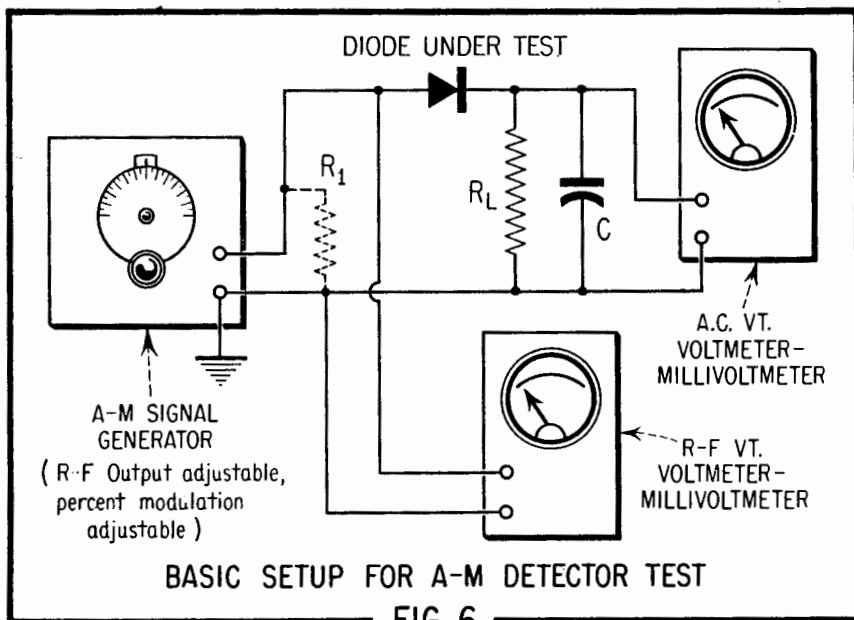

FIG. 6

The type of transformer and its characteristics depend upon the test frequency. This unit will be iron-cored for audio and power-line frequencies, and will be of either air-core, powdered-iron, or ferrite-cored type for radio frequencies.

The input voltage ( $E_{ac}$ ), indicated by the a-c vacuum-tube voltmeter, is adjusted to the required level, and the d-c output voltage ( $E_{dc}$ ), developed across the load resistance ( $R$ ), is read from the d-c vacuum-tube voltmeter. The required values of  $R$  and  $C$  usually are given in the specifications of the diode under test (a common combination is  $R = 5000$  ohms,  $C = 20$  uufd,  $f = 10$  Mc.)

The rectification efficiency ( $n$ ) equals the d-c voltage ( $E_{dc}$ ) divided by the peak a-c voltage ( $E_{ac} \times 1.414$ ).

Expressed as a percentage, this fraction must be multiplied by 100. Thus,  $n = 100E_{dc}/(1.414E_{ac})$ . Rectification efficiency varies directly as the a-c voltage amplitude, frequency, and load resistance.

**A-M Detector Test.** An important use of small diodes is in detector (demodulator) circuits. In this application, the function of the diode is to separate the modulation component from the carrier component in an amplitude-modulated wave.

Figure 6 shows an apparatus setup for checking detector action. The a-m signal is supplied by a signal generator in which the output and the modulation percentage each are continuously variable. Resistance  $R_1$  is a low resistance and is not required if the output circuit of the signal generator contains a low-resist-

ance d-c return path for the diode under test. The signal level is monitored by the r-f vacuum-tube voltmeter-millivoltmeter. The diode output, developed across the load resistance,  $R_L$ , is monitored by the a-c vacuum-tube voltmeter-millivoltmeter.

At a given value of modulation percentage and carrier amplitude, the efficiency of the diode as a detector is proportional to the voltage indicated by the audio meter (a-c v-t voltmeter). For a complete evaluation, the test should be repeated at various signal-voltage and modulation-percentage levels and at several carrier frequencies. At low signal levels, response of the diode will be observed to be approximately square law.

The value of load resistance  $R_L$  usually is prescribed in the detector diode specifications. Capacitance  $C$  is chosen for effective bypassing of the carrier-frequency current component. If no value is specified for  $R_L$ , this resistance should be that value into which the diode will operate when installed in the equipment in which it is to be used.

**Television Diode Test.** A variation of the detector test setup, for tv diodes, is shown in Figure 7. In this arrangement, a 40-Mc, 70-percent amplitude-modulated signal is applied to the diode under test. This is the arrangement suggested by the Joint Electronic Tube Engineering Council, JETEC (See *Sylvania Engineering Information Service*, August 1954).

The test procedure is the same as in the a-m detector test described in the preceding Section, except that the carrier frequency and modulation frequency are maintained constant.

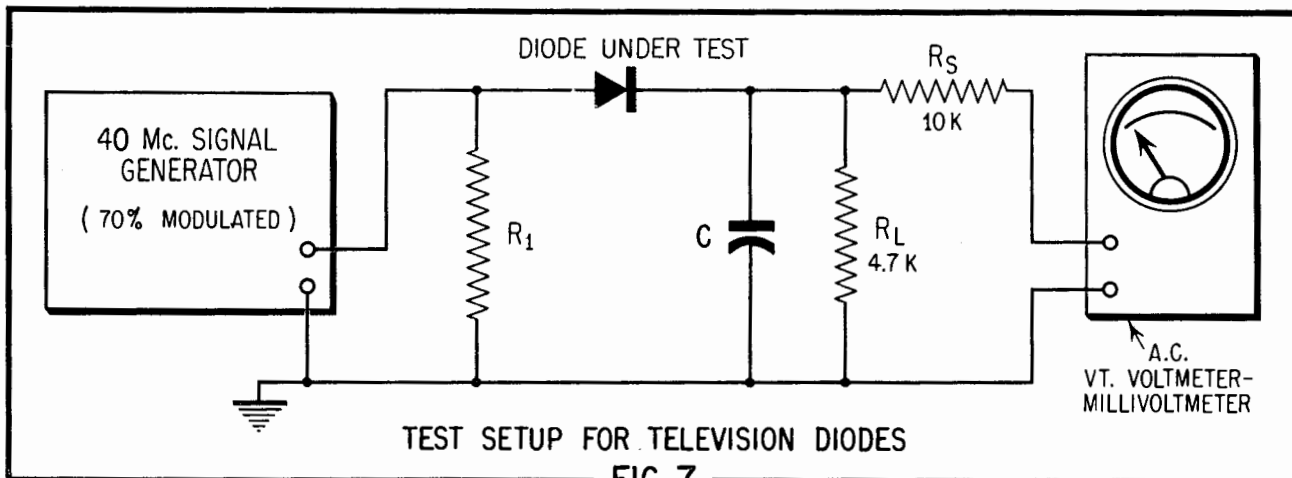

FIG. 7

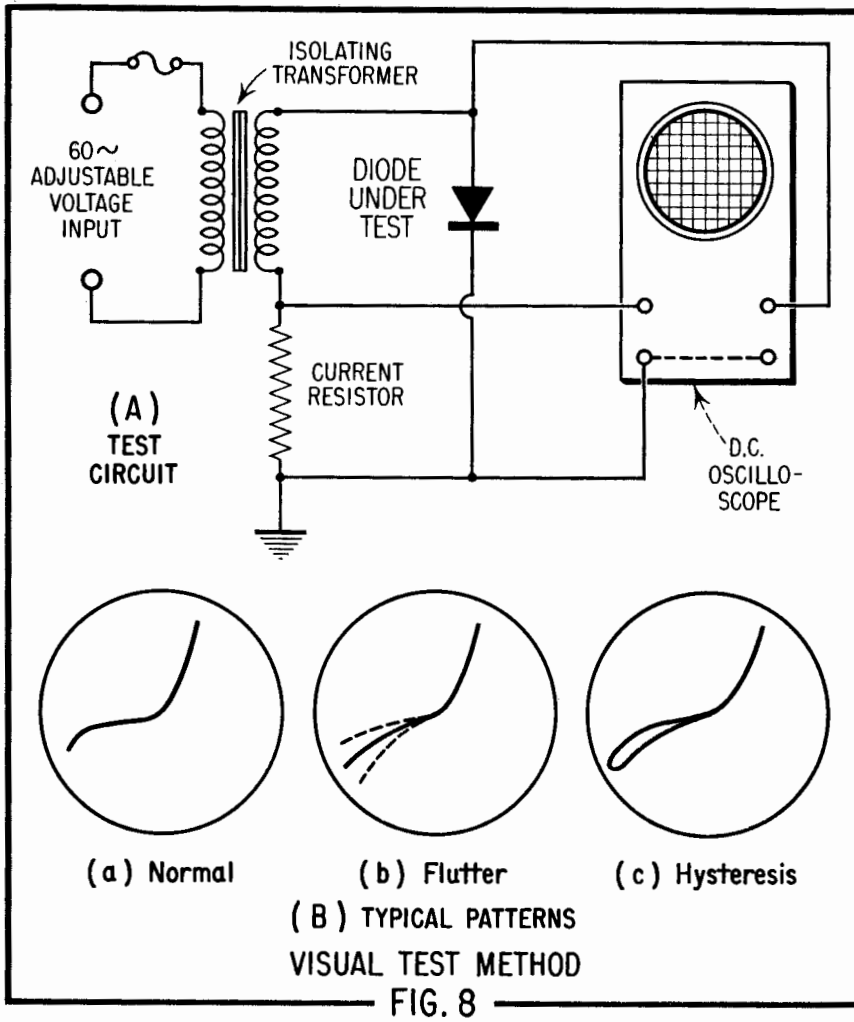

FIG. 8

**Visual Test Method**

It was mentioned earlier that the production of a diode conduction curve, such as Figure 2 is a tedious process requiring the painstaking accumulation of current and voltage values point-by-point. It thus becomes costly to evaluate a large number of diodes by this method.

A visual test method which is dynamic in nature gives a display of the complete curve on an oscilloscope screen. Figure 8(A) shows a circuit for visual display of the diode characteristic. The diode under test is connected in series with an a-c bias supply and a current resistor. This resistance is low with respect to the diode forward resistance and usually is between 1 and 10 ohms.

During the half-cycle of applied 60-cycle voltage when the anode of the diode is positive, high forward current flows through the current resistor. During the negative half-cycle, the anode is biased negatively and small reverse current flows

through the resistor. The voltage drop across the current resistor is proportional to the forward and reverse currents and is applied to the vertical input of the oscilloscope. Vertical deflection thus is proportional to current. The transformer output voltage is applied to the horizontal input of the oscilloscope. The horizontal deflection accordingly is proportional to the diode voltage.

The reason for using a d-c oscilloscope is that the direct-coupled nature of its circuitry enables definite establishment and identification of the zero current and voltage point (origin) in the pattern. The horizontal axis may be calibrated in volts (forward and reverse) and the vertical axis in amperes, milliamperes, or microamperes forward and reverse.)

Figure 8(B) shows typical patterns displayed by the curve tracer circuit. Pattern (a) is the type normally obtained for a good diode. The negative (reverse) portion of (b)

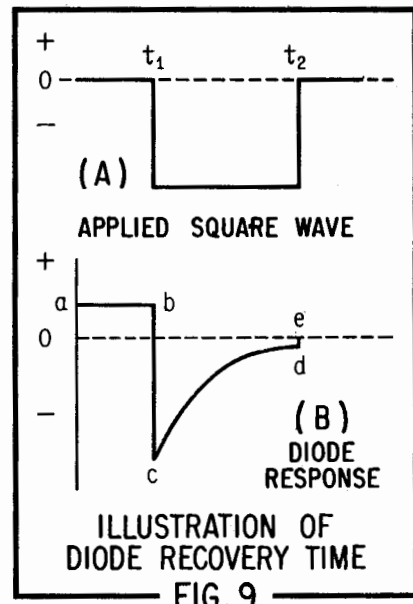

FIG. 9

changes its position intermittently, or *flutters*, indicating instability. This condition occasionally is observed also in the forward (positive) region of the curve. In (c), the reverse portion of the curve is seen to be traced along one route from zero to maximum, but to return along another route from maximum back to zero. This opening-up of the curve is termed *hysteresis*, a condition which often foretells early failure of the diode.

**Checking Recovery Time**

A semiconductor diode has the peculiar property that its reverse current will be relatively high (reverse resistance low) for an instant immediately after applying the reverse voltage if the diode has just been conducting forward current. After this initial high-current transient, the reverse current then decreases gradually (resistance increases) to a value in line with the applied voltage. The interval during which the current settles to its rated level is termed *recovery time*.

Recovery time increases with the level of recent forward current. It is longer in junction diodes than in point-contact types. Short recovery time is particularly desirable in digital computers and similar pulse-type circuits in which diode conduction is switched rapidly from forward to reverse.

The wave pattern in Figure 9(B) illustrates diode reverse-current recovery effect. The diode conducts forward current during the interval from a to b. Instant b corresponds to time  $t_1$  (See Figure 9A). At b,

a negative-going square wave of voltage (Figure 9A) is applied. Because of its recent forward-current history, the diode cannot establish a high reverse resistance immediately, and as a result the reverse current increases instantaneously to c. Subsequently, it decreases to d, and at time  $t_2$  follows the fall of the square wave back to zero. The time interval involved in the "recovery transient" is a mat-

ter of microseconds, the maximum being of the order of 10 microseconds for large-area germanium rectifiers, and 1 or less for point-contact germanium diodes. The depth of the initial current spike likewise is greatest with large-area germanium rectifiers and is least in point-contact silicon units.

Recovery time may be checked by applying a negative square wave (usu-

ally at a repetition rate of 100 kc) to the diode carrying forward current. The diode current flows through a series resistor and the resulting voltage drop across this resistor is applied to the vertical input of a high-speed, direct-coupled oscilloscope adjusted to display one square-wave cycle. The oscilloscope screen is graduated vertically in microamperes and horizontally in microseconds.

## Improved, Crystal-Type Noise Generator

THE satisfactory repair of modern high-gain electronic equipment, such as amplifiers and receivers, as well as the development of this apparatus, often involves some kind of noise level measurement. The technician's attention is being directed increasingly to this subject by the specifications and performance requirements for preamplifiers, preselectors, boosters, complete audio

amplifiers, complete video amplifiers, and communications receivers.

The normal presence of an electrical noise background in high-gain equipment is well-known. Its theoretical aspects have been treated thoroughly elsewhere and will not be discussed here. The technician understands that internal noise arises inherently from current flow and/or thermal action in tubes, resistors,

contacts, etc. and that its presence limits the smallest signal which can be amplified or even handled by a system. While electrical noise possesses a number of distinguishing characteristics, the principal ones are its random nature, the distribution of its energy over an extremely wide band of frequencies, and its characteristic acoustic unpleasantness. Its multi-component waveform

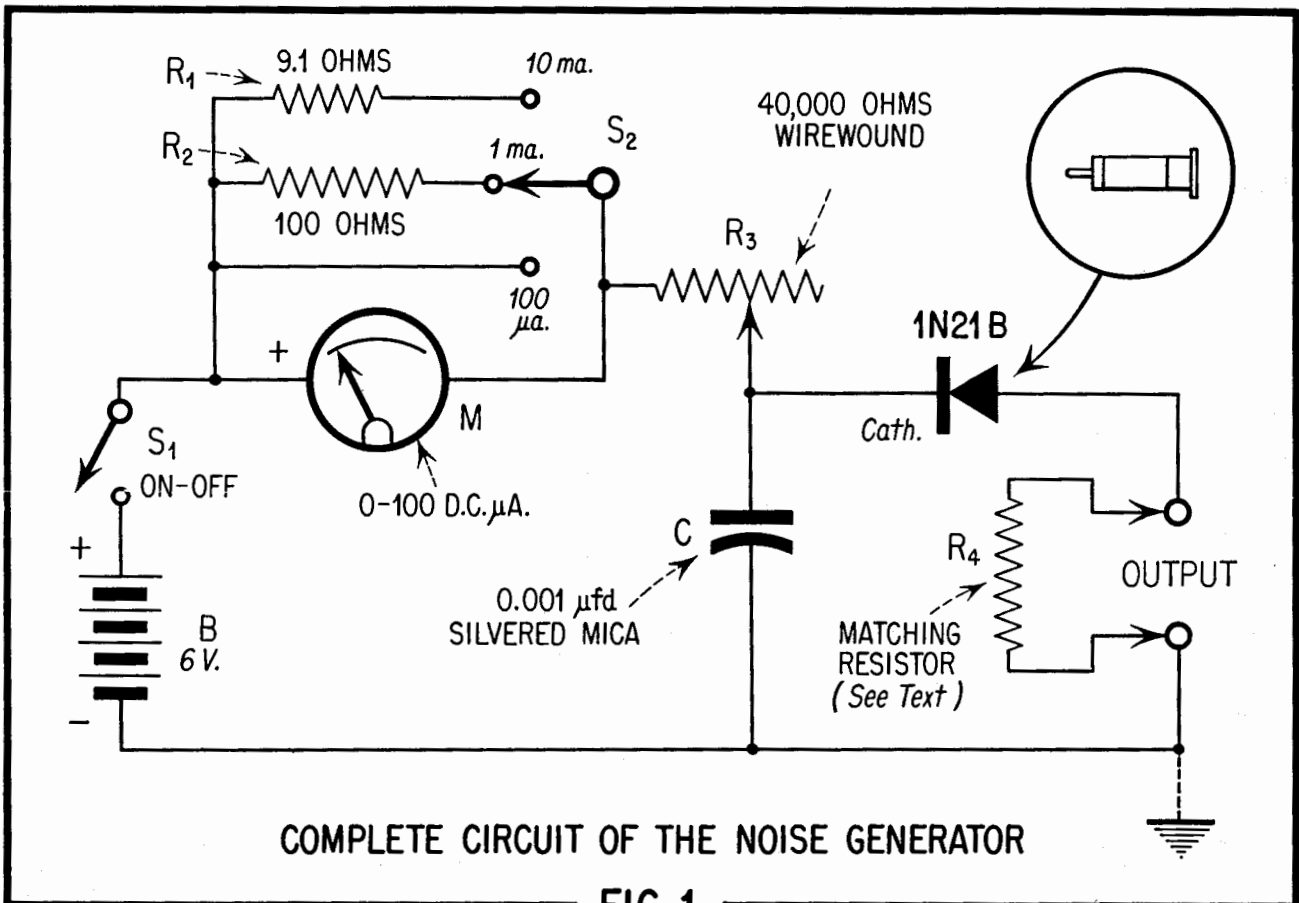

contains jagged peaks and amplitude smears.

The residual noise level at the output terminals of an equipment may be measured with an oscilloscope or suitable a-c millivoltmeter. Generally, the input terminals of the equipment are short-circuited, although some specifications may call for measurements with the input open. The residual output signal can contain, in addition to noise, other components due to hum arising within the equipment or oscillation. Obviously, every effort must be made to separate the noise voltage from any other such components if the noise measurement is to be valid. This is not often easy. It is interesting to note, however, that an occasional specification will lump the total residual small output due to all such factors under the generic heading of noise.

A standard method of noise measurement consists of feeding an adjustable-amplitude noise signal into the input circuit of an equipment under test while monitoring the noise-output power of the equipment, and noting the increase in noise-input amplitude required to double the output-noise power. The input noise then equals the internal noise of the equipment; and from these data, a noise factor may be calculated. If a wattmeter is not available, the output-noise voltage may be monitored in lieu of noise power, an increase in output voltage of 1.41 times corresponding to doubling the power. Both receivers and amplifiers are checked in this manner.

The noise test signal is derived from a noise generator, of which there are several types. Laboratory versions of this instrument are based upon a special temperature-limited noise-diode tube (example, Sylvania Type 5722). When the plate voltage of this tube is adjusted to the level at which the filament emission is saturated (that is, all emitted electrons are collected by the plate), the shot noise generated by the diode has constant amplitude and its energy is distributed over a wide spectrum. At intermediate plate voltages, the diode noise output is proportional to the d-c plate current. Thus, by providing for smooth variation of the diode plate voltage, a noise signal of continuously variable amplitude may be obtained. The a-c noise component generated by the tube is coupled, through the noise generator output circuit, to the input of the amplifier or receiver under test.

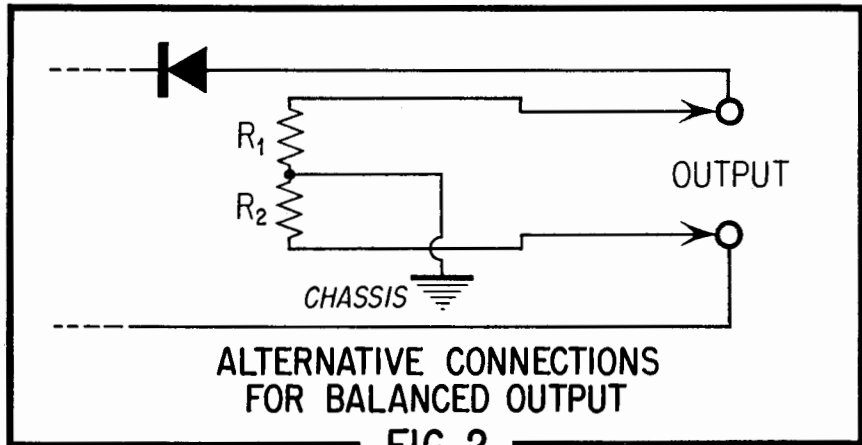

#### Crystal-Type Noise Generator

The diodes employed in tube-type noise generators are rather expensive. This factor plus the need for both filament and plate power supplies render the tube-type instrument unattractive to the technician and to the low-budget laboratorian.

A much simpler, yet effective noise generator utilizes the inherent noisiness of a d-c reverse-biased point-contact silicon diode. The noise component arising from diodes of this type have been used for testing at frequencies up to 3000 megacycles and higher. The circuit of a noise generator based upon a silicon diode is very simple, inexpensive, and reasonably rugged. It is completely suitable for the comparative measurements which suffice in common service and experimental applications.

Basically, the crystal-type noise generator consists of a point-contact silicon diode, such as 1N21A or 1N21B. (Germanium and silicon junction types are unsatisfactory). The diode is reverse-connected across a battery; that is, with the diode anode negative, and a means is provided for coupling the noise energy, generated by the flow of current through the diode, out of the circuit. Several such generators have appeared in the literature but in general have been makeshift in character and have included no means for dependable control of the noise amplitude.

The circuit of an improved generator is given in Figure 1. In this arrangement, the diode current is adjusted by means of the 40,000-ohm wirewound rheostat,  $R_3$ . The current level is indicated by the multirange meter,  $M$ . This meter has three ranges, selected by switch  $S_2$ : 0-100 microamperes, 0-1 milliamperes, and 0-10 milliamperes.

This arrangement for constant monitoring of the current over a possible range of 5000 to 1 enables reasonably accurate re-setting of the output-noise level. The resistance values of the two meter shunt resistors,  $R_1$  and  $R_2$ , are based upon an internal meter resistance of 900 ohms. This is the resistance of the Triplett Model 327-T instrument employed in the writer's prototype. Some variation will be necessary when an individual internal meter resistance differs from this 900-ohm value. In any case, the required shunt resistance (in ohms) equals  $r_m/9$  for the 1-ma range, and  $r_m/99$  for 10 ma. The numerator,  $r_m$ , is the internal meter resistance, in ohms.

The a-c noise component due to random fluctuations of current in the diode is transmitted to the OUTPUT terminals through the 0.001-ufd silvered mica capacitor,  $C$ . For a-c, this capacitor forms a closed circuit comprising the 1N21B,  $C$ , and the OUTPUT terminals.

A non-inductive (good-grade composition or carbon film) resistor,  $R_4$ , bridges the OUTPUT terminals to match the input resistance, or impedance, of the device under test. If the noise generator is used, for example, with a receiver having an input impedance of 300 ohms,  $R_4$  will be 300 ohms. Resistor  $R_4$  need not be larger than 1/2 watt. Since many different input impedances are encountered in amplifiers and receivers, the question will arise as to why a switching arrangement has not been employed here to give the noise generator a wide range of output impedance. The reason for not doing this was to avoid the inherent noise-generating properties of such a switching circuit. In fact, in order to keep all internal noise not arising in the diode, and extraneous pickup at a minimum, resistor  $R_4$ , diode

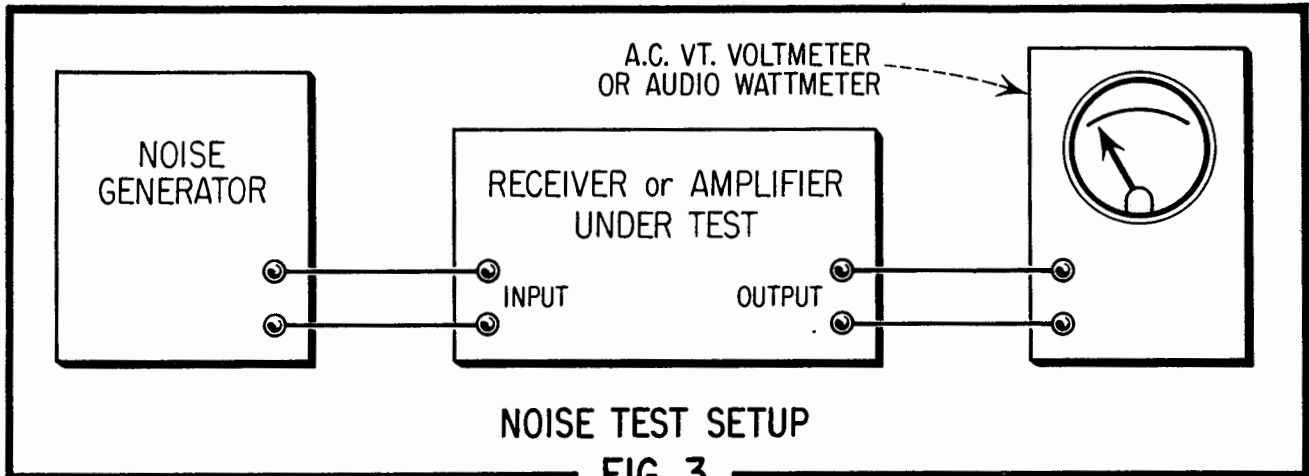

1N21B, and capacitor C must be mounted right at the OUTPUT terminals. This insures the shortest possible leads. When the generator is to operate into a new impedance, Z, a new resistor  $R_4$  equal to Z must be fastened directly across the OUTPUT terminals.

When the device under test has a balanced input circuit, as often is the case in television receivers, two series-connected resistors with their junction grounded can be connected, for impedance-matching, across the noise generator OUTPUT terminals in the manner shown in Figure 2. The value of each resistor is equal to  $\frac{1}{2}Z$ , where Z is the input impedance of the device under test.

Whether the generator has balanced output (Figure 2) or unbalanced output (Figure 1), its ground must be connected solidly to the ground of the device under test.

#### Construction

The simplicity of the noise generator circuit removes any complication of construction. By using a 6-volt battery (B) of thin, flat construction, like Burgess Type 5540 (4" x  $\frac{7}{8}$ " x 2- $\frac{3}{4}$ "), the entire instrument may be housed in a metal radio utility box slightly larger than a standard meter case.

The insert in Figure 1 shows the shape of the 1N21B diode. The metal tip on the left end of this figure is the cathode terminal which is con-

nected to the junction of rheostat  $R_3$  and capacitor C.

The only wiring precaution is to keep all connections between the diode, capacitor, OUTPUT terminals, and  $R_4$  as short as possible. To accomplish this, solder the base of the diode directly to the upper OUTPUT terminal, and solder capacitor C from the tip of the diode to the lower OUTPUT terminal. In order to prevent damage to the diode during this operation, hold with metal pliers the metal part of the diode being soldered. This will conduct the heat away from the diode case. Continue to grip with the pliers until the diode is unmistakably cool to the touch.

#### Operation

Figure 3 shows a typical setup for noise measurements. The following test procedure is recommended: (1) With the noise generator switched-off, note the reading of the output meter (a-c v-t voltmeter or audio wattmeter) when the amplifier or receiver is in operation and its output controls are set for normal operation. (2) Record this deflection of the output meter, due to the inherent internal noise level of the equipment under test, as the "zero level." (3) Switch-on the noise meter and increase its output by adjusting rheostat  $R_3$ , until the output power of the amplifier or receiver (when the output meter is a wattmeter) is dou-

bled, or until the output voltage (when the meter is a voltmeter) is increased 1.41 times. (4) Note the reading of the current meter, M. High current values indicate a high noise level in the device under test, and vice versa. After work is done in the device, a decrease in the initial current reading obtained in a repeated step 4 indicates an improvement in the noise characteristic; an increase in meter M deflection shows a worsening of the noise.

In addition to the comparative type of measurement just described, the noise generator output may be calibrated quantitatively. One method is to plot the noise output voltage (E) at the generator output terminals vs meter M readings for a given output impedance,  $R_4$ . Either these voltages might be used in subsequent noise tests, or the noise power levels might be calculated:  $P = E^2/R_4$  watts. For either voltage or power, a separate calibration is required with each output impedance,  $R_4$ .

The technician will find noise measurements advantageous in checking the performance of all-wave receivers, television receivers, and amplifier systems for sound reproduction. These measurements are particularly revealing when used to determine the efficacy of TV boosters, since the latter devices are known to suffer occasionally from prohibitive noise.

# SECTION VI

## SPECIALIZED APPLICATION AND DEVELOPMENT

### Using Standard Time and Frequency Broadcasts

THE standard time and frequency transmissions of the National Bureau of Standards radio stations WWV and WWVH provide an invaluable service to laboratories and individual experimenters throughout the world. Extremely precise audio and radio frequency standards, as well as accurate time intervals and radio frequency propagation warnings, are placed at the disposal of anyone having a receiver capable of tuning to one or more of the transmitting frequencies. The proper use of these facilities can be made to greatly supplement the instrumentation of any laboratory. However, the maximum utilization of this valuable "natural resource" depends upon a knowledge of the broadcasting schedules, transmitting frequencies, and suitable methods of comparison.

The standard frequency stations WWV and WWVH are operated by the Central Radio Propagation Laboratory of the National Bureau of Standards. Station WWV is located at Beltsville, Md. (near Washington, D. C.), and WWVH is on the island of Maui, Hawaiian Islands. Both stations broadcast continuously on the carrier frequencies and with the output powers shown in Table 1. This diversity of geographical location and transmitting frequencies places the services of these stations on an essentially world-wide coverage basis.

The standard carrier frequency transmissions of WWV and WWVH are modulated with various standard audio tones and time interval signals in order to provide calibration information for a wide variety of instruments. During the first four minutes of each five minute interval, starting

on the hour, the carriers are modulated by accurate sinusoidal tone signals; 600 cycles per second is used during the first four minute period, followed by 440 cycles during the second period, etc. These two audio frequencies are alternated each five minutes throughout the hour. At the beginning of the fifth minute of each five minute interval, the tone modulation is interrupted for exactly one minute during which station identification is given in voice from WWV and in International Morse Code from WWVH. Also during this minute, Eastern Standard Time is announced from WWV in voice, and Universal Time is sent in code from both stations.

During the entire transmission, a five-millisecond (.005 second) pulse signal is superimposed upon the carrier. This pulse consists of five cycles

of a one kilocycle sine wave and is heard as a sharp "tick" which accurately marks the passage of each sound. This "seconds pulse" is omitted on the 59th second of each minute to accurately identify one minute intervals. Figure 1 illustrates the transmitting cycle of WWV which is repeated every ten minutes, starting on the hour.

#### *New Propagation Disturbance Notices*

In addition to the standard time and frequency transmissions, WWV also broadcasts radio propagation disturbance warning notices for the benefit of commercial services and amateurs whose communications depend upon conditions in the ionosphere. These announcements are made in code during the 19th and 49th minutes of each hour. As of July 1, 1952 the system was revised to include not only the transmission of a symbol to indicate the present ion-

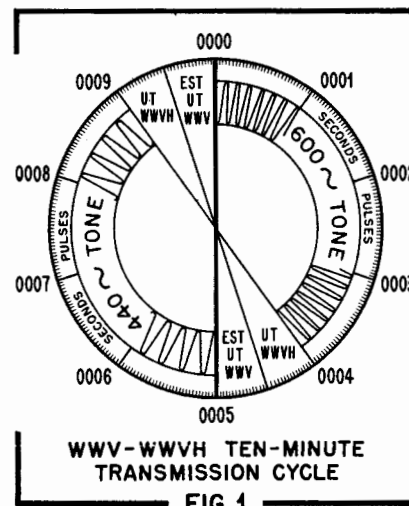

TABLE I	
FREQ. (MC.)	POWER (KW.)
<b>WWV</b>	
2.5	0.7
5	8.0
10	9.0
15	9.0
20	8.5*
25	.1
<b>WWVH</b>	
5	0.4
10	0.4
15	0.4

\* Reduced to 0.1 KW. for first four work days following first Sunday of even months.



ospheric conditions affecting communication paths over the North Atlantic, but also a numeral to indicate the condition forecast for the next 12 hours. Thus, the letters "N", "U", or "W" sent five times in code mean that the present radio reception conditions are "normal", "unsettled", or "disturbed", respectively, while a numeral which follows each letter indicates that the forecast for the next 12 hours is for conditions to continue as follows:

Numeral	Forecast Propagation Condition
1	Impossible
2	Very Poor
3	Poor
4	Fair to Poor
5	Fair
6	Fair to Good
7	Good
8	Very Good
9	Excellent

According to this system, the characters "W7" transmitted from WWV would be interpreted to mean that the present ionospheric conditions affecting radio propagation were "disturbed" but expected to improve to "good" within the next 12 hours.

#### Accuracy of Transmissions

The accuracies of the audio and radio frequencies and other information broadcast by stations WWV and WWVH are as great as the present state of the engineering art will permit. All frequencies transmitted from both stations are accurate to within 2 parts in one-hundred million. A discussion of the means employed to insure this precision is of general interest and aids in gaining an appreciation of the meticulous care required to maintain the national primary frequency standard.

The carrier frequencies at WWV are derived from the average of eight precision quartz crystal oscillators which are operated continuously. These oscillators all operate on 100 kilocycles per second from battery power and are housed in subterranean vaults twenty-five feet below the earth's surface. The temperature and humidity of these vaults are very carefully controlled to insure maximum frequency stability. The frequencies of the oscillators are compared continually among themselves and are checked against the basic frequency standard — the period of the earth's rotation. The "control standard" oscillator which is chosen to control WWV drives a chain of frequency dividers and multipliers which convert the fundamental 100

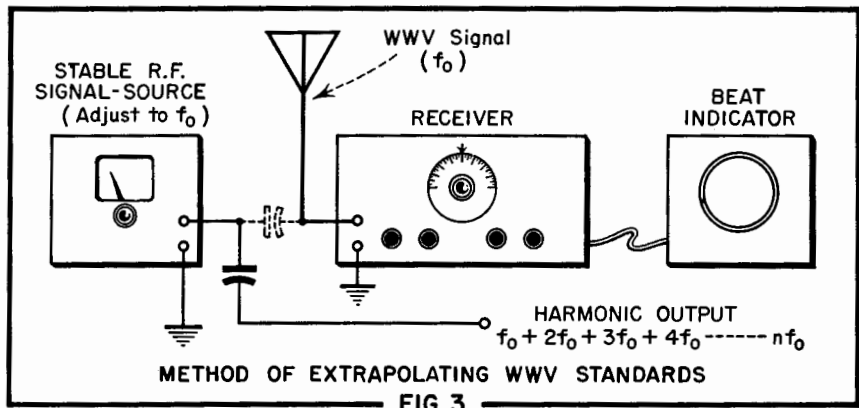
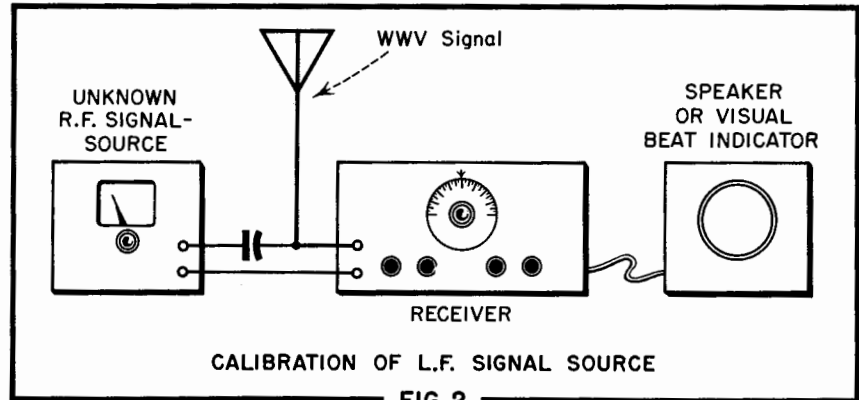

kc. frequency to a wide variety of standards ranging from 1 cps. to 30,000mc. All radio and audio frequencies broadcast are thus derived from one oscillator and are therefore of comparable accuracy. The 60 cycle standard is used to drive a synchronous clock motor which allows the standard to be checked against Naval Observatory time. In this manner, the time signals as broadcast from WWV agree with Naval Observatory time within several hundredths of a second and have a diurnal variation which never exceeds 2 milliseconds.

The frequency standards at WWVH are similar to those used at WWV and are maintained in agreement with WWV signals to within 2 parts in 100 million by comparison. These comparisons are made during the four minutes following each hour and half-hour when WWVH is off the air and during 34 minute interruptions which occur at 1900 hours GMT.

#### Methods of Comparison

From most points in the continental United States, the standard frequency broadcasts of WWV can be received on a relatively simple receiver. One of the superheterodyne type having good selectivity and auto-

matic volume control is to be preferred, however. These features are usually found in communications-type receivers. Under normal propagation conditions, such receivers are capable of receiving WWV or WWVH transmissions on several of the standard frequencies, thus permitting good flexibility of measurement.

**Carrier Frequency Check Points.** The simplest and most direct way of utilizing standard frequency transmissions is the use of the transmitted signals as check points to calibrate the dial of a receiver. The variety of transmitted frequencies usually insures that one WWV signal falls within each tuning range of multi-band receivers. The accuracy of the receiver dial calibration may then be checked against the standard frequency carrier and any serious deviation corrected by adjusting either the receiver dial mechanically, or the receiver local oscillator trimmer. In all cases, the receiver should be allowed to reach thermal equilibrium before comparisons are made.

**Calibration of Low-Frequency R. F. Signal Sources.** Figure 2 illustrates a method of comparing the frequency of tunable signal sources such as signal generators, grid-dip meters, and amateur vfo's with the WWV stand-

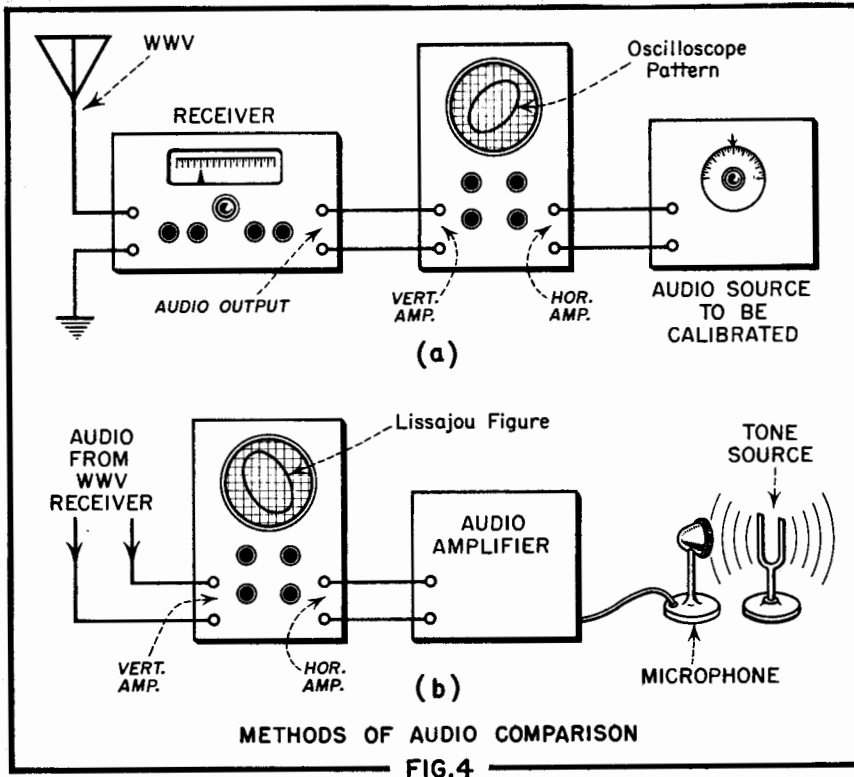

FIG. 4

ard. The method is also applicable to fixed frequency standard oscillators which operate close to some *submultiple* of a WWV carrier frequency. The signal source to be calibrated is loosely coupled by radiation or capacity coupling to the WWV receiver, which is carefully tuned to an appropriate WWV signal. The frequency of the signal source is then varied until a beat note between one of its harmonics and the WWV carrier is heard in the receiver output. When the local signal is adjusted to produce zero beat, its frequency is exactly equal to that of WWV or is an exact submultiple of it. If the device being checked has an approximate calibration, the order of the harmonic is easily identified. Otherwise, the fundamental frequency of the unknown source can be found by determining the frequency difference between two adjacent harmonics on the receiver. Thus, a 1 megacycle signal will produce a beat with the 5

megacycle carrier of WWV and will also be heard at 4 and 6 megacycles on the communication receiver, while a .5 megacycle signal will beat with the 5 megacycle carrier and will also be heard at 4.5 and 5.5 megacycles. This makes it possible to obtain many check points which will be highly accurate as long as the integral multiple is maintained at zero beat with WWV. A visual beat indicator, such as an audio output meter across the receiver output, is usually more accurate than the aural method.

*Upward Extension of Standard Frequencies.* The method previously described allows frequencies *lower* or *equal* to the WWV standard to be calibrated. When it is necessary to provide standard check points at frequencies considerably *higher* than the highest available WWV carrier, the arrangement shown in Fig. 3 is employed. In this method, a tunable r.f. oscillator of suitable frequency sta-

bility is zero beat in a receiver with the WWV standard. The harmonics of this oscillator will then appear at precisely integral multiples of the standard frequency to which it is referred. If the auxiliary oscillator has sufficient power output, these harmonics will extend quite high in frequency and may be used as "markers" throughout the VHF and lower UHF regions. The method, wherein a crystal oscillator of conventional design is adjusted to operate at zero beat with WWV and supplied with unfiltered d.c. to enhance the harmonic content, is ideal for this purpose. A secondary standard of some type will usually be required to identify harmonics.

*Audio Frequency Comparisons.* Electronic audio equipment, as well as musical instruments capable of sustained tones, may be referred to the 440 and 600 cycle tones broadcast by WWV or WWVH by means of the lay-outs illustrated in Fig. 4. For audio oscillators and other equipment having an electrical output signal, Fig. 4a is employed. The output of the WWV receiver (tone control and beat frequency oscillator off) is coupled to the amplifier feeding one set of plates of an oscilloscope, while the output of the device being calibrated is coupled to the amplifier feeding the other set of deflection plates. When the frequency of the local source is adjusted to equal the audio tone being transmitted by WWV, a stationary circle or ellipse will appear on the cathode ray tube. Other integral multiples or submultiples may easily be identified by means of the Lissajou figure produced. A description of the use of Lissajou Patterns may be found in any engineering text.

To calibrate the musical pitch produced by non-electronic sources, the equipment shown in Fig. 4b is required. Since the source does not produce an electrical audio output, a microphone and suitable audio amplifier must be used to convert the audio output of the device into an electrical signal for comparison with that received from WWV. As in Fig. 4a, the frequency of the unknown source is identified by the oscilloscope pattern produced.

## Photoelectric Cell Applications

THE photoelectric cell, or "electric eye" as it is often referred to, has many applications—from use in burg-

lar alarms and smoke detectors to facsimile, television, and even the measurement of microscopic tissue cells.

It is based on a discovery by Hertz in 1887 that emission of electrons can be caused by light striking the surface

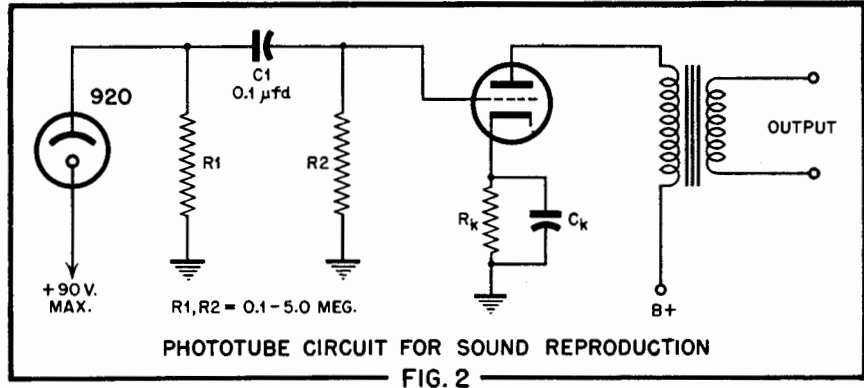
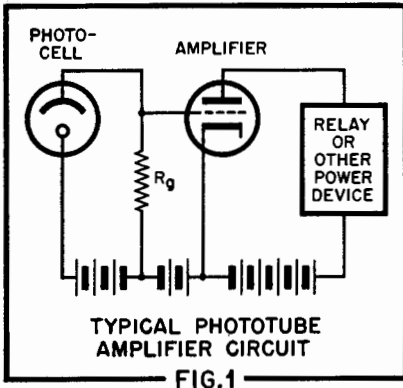

of certain materials such as sodium and potassium.

Photosensitive devices fall into three general classes: (1) *photoelectric* or "phototubes", (2) *photoconductive* cells, and (3) *photovoltaic* cells. Phototubes are those in which impinging light causes emission of electrons from the photosensitive surface. Most practical photosensitive devices, such as the burglar alarm, automatic counter, door opener, and smoke detector, fall in this category. Photoconductive cells are those in which the internal resistance varies with the amount of light striking the sensitive surface. These cells are used to operate very sensitive relays and in the measurement of infrared radiation. Photovoltaic cells are those which generate an internal emf upon exposure to light. The ordinary light-intensity meter used in photography employs a photovoltaic cell connected directly across a low resistance meter.

This discussion is devoted to some typical applications of the various types of photosensitive devices mentioned above.

#### Phototubes

Commercial phototubes are essentially diodes contained in glass envelopes very similar to those used for thermionic vacuum tubes. The cathode is usually a large semi-cylindrical surface coated with a photoemissive material. The anode is a wire lying parallel to the cathode axis. These elements may be inclosed in an evacuated bulb, or one which is gas-filled. The gas tubes ionize when the plate voltage exceeds a certain value and thus pass a larger current than do the high vacuum types. Gas-filled tubes are employed largely in motion picture work where their higher sensitivity reduces the amplification needed. High vacuum phototubes are used in light measurement work and in certain relay operating applications. They are less subject to damage due to application of excessive voltage or current, and their sen-

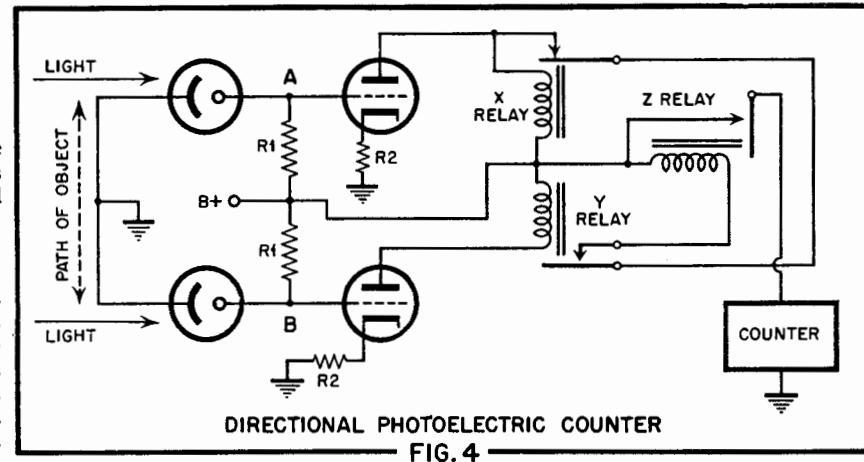
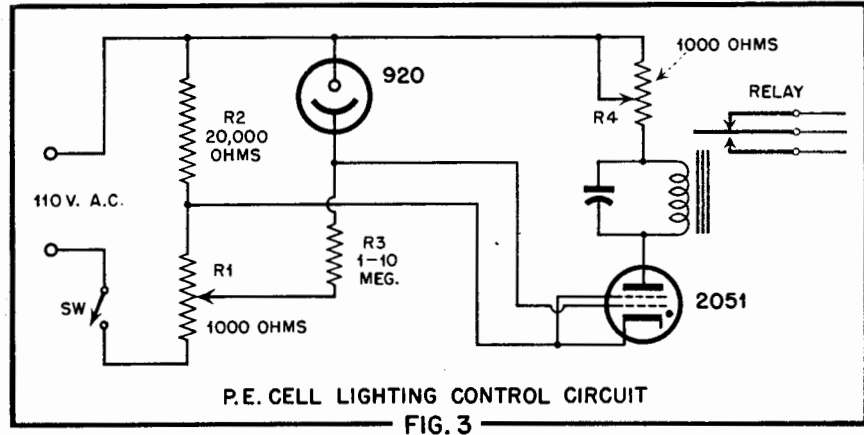

sitivity remains more constant over a period of time.

The most common applications of phototubes involve the use of associated vacuum tube amplifiers, as in Fig. 1. The tube is coupled to the input of an amplifier by means of a large resistance,  $R_g$ . Since the current flow through the cell is of the order of a few microamperes, this resistance should be very high. By proper amplifying circuits, the current in the final output stage of the amplifier may be sufficient to operate a relay

or a loudspeaker as in the sound picture industry. See Fig. 2.

Another valuable application of the photoelectric cell is the control of lighting. The tube is used with an amplifier and relay to turn the lighting system on when daylight decreases and off when natural light is again adequate. Fig. 3 illustrates a circuit in which the relay is energized by an increase in light. As long as the illuminator on the phototube is below a certain value, the 2051 grid potential is below cutoff, and prevents

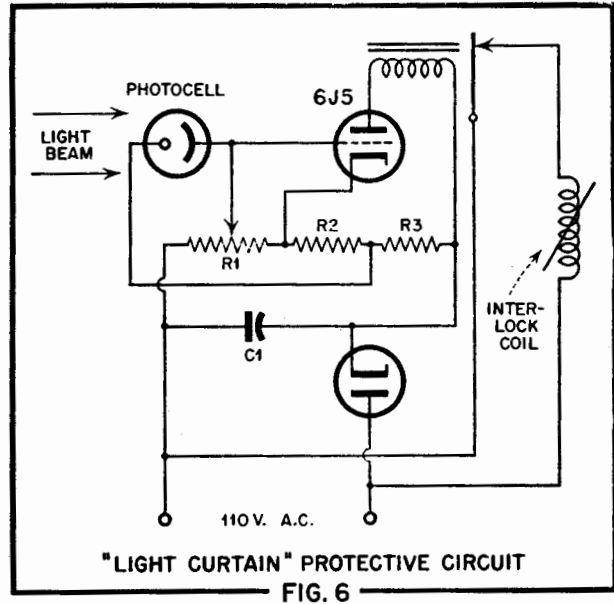
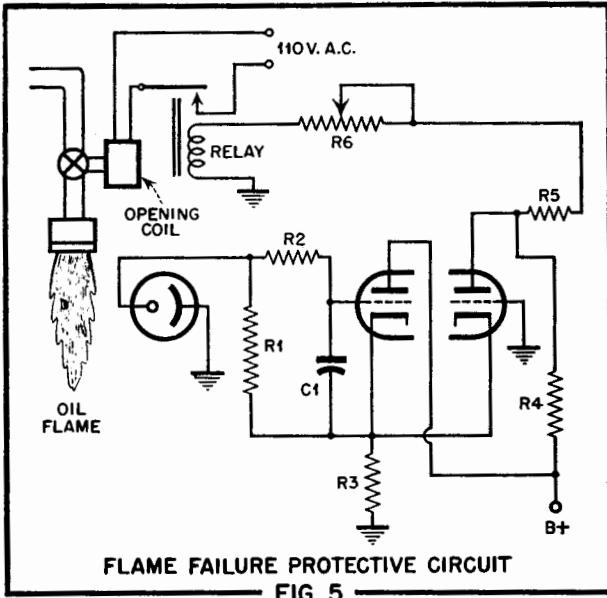

conduction. When illumination rises, grid voltage is made less negative and the tube conducts, closing the relay. The function of R4 is to keep the current through the 2051 within the tubes maximum rating. Note that this circuit works directly on a.c. line voltage, requiring no d.c. supply.

#### Photoelectric Counting System

The simplest use of the phototube and relay is that of counting. A beam of light is directed across a conveyor belt into a photoelectric tube which operates a counter. When the beam of light is interrupted by one of the objects to be counted, the change in tube current operates the counter. An interesting circuit of this type is the one-way counter illustrated in Fig. 4. This arrangement records objects passing in one direction, but not in the other.

Suppose an object is passing downward in Fig. 4 so that it obscures phototube A and then B. When the light to tube A is interrupted, plate current flows in tube X, opening the contacts of relay X. As the object

continues downward, both tubes are obscured and relay Y closes. But since the contacts of X relay are open, no current flows through the Z relay and the counter is inoperable. Now suppose that the object passes from B to A. Relay X does not operate and its contacts remain closed. Thus, the counter is actuated only by objects passing in the direction from B to A.

#### Industrial Safety Controls

The applications of photoelectric cells to safety devices are very numerous. Some of the more familiar safety controls are the smoke detectors, traffic control, and protective door openers which prevent automatic doors from closing until personnel are clear. Another important protective circuit of this type is the flame-failure

detector shown in Fig. 5. This device, intended to safeguard oil furnaces, uses a dual triode as its principal element. When light from the flame is present, photocurrent flows and the first triode section is blocked. The second triode section normally conducts current enough to close the relay which opens the solenoid oil valve and allows the flame to burn. Should a flame failure occur, the photocell no longer provides blocking voltage to the first section, which then conducts and applies a blocking voltage to the grid of the second triode section. The blocking of current in the second triode opens the relay and closes the oil valve with the simultaneous ringing of an alarm bell.

An even more common kind of industrial safety control is the "light curtain" type of protective device used to safeguard the operators of heavy machines. In this application of photoelectric devices, a light curtain is formed about the area of danger by a series of beam projectors and mirrors, the beam falling ultimately on a set of phototubes. If the opera-

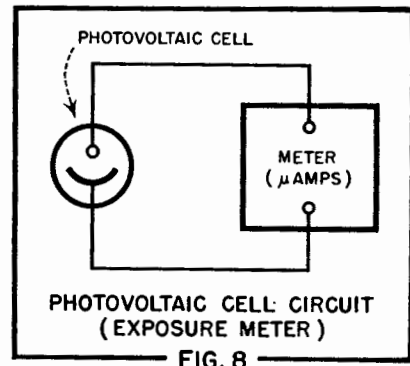
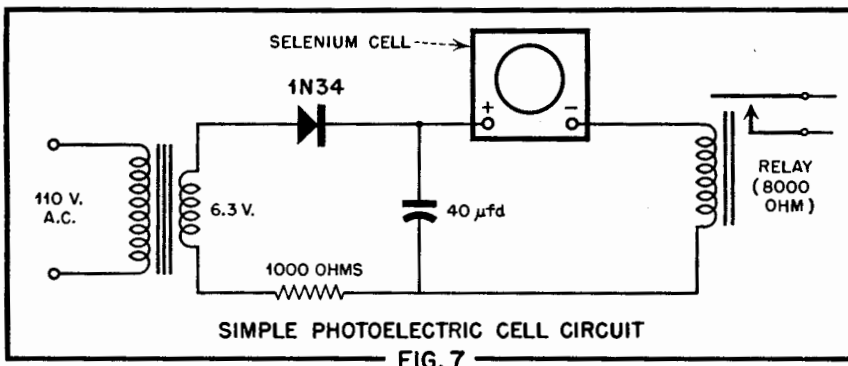

tor inadvertently reaches into the protected area, one of the beams of light is interrupted and the machinery is stopped by an interlock operated by the photocell relay. Fig. 6 is a typical circuit of this kind. Here the bias potentiometer (R1) is adjusted to cut-off so that the 6J5 does not conduct in the absence of light on the photocell cathode. With incident light the photocurrent through this bias resistor causes the tube to conduct and operate its load relay which, in turn, operates an interlock which permits the machine to operate. Interruption of the incident light beam causes the 6J5 to cut off and stops or delays the operation of the machine. A safety control of this type is most frequently used with punch presses.

#### Photoelectric Gages

Phototubes also find many applications in the measurement of time, distance, thickness of materials, etc. A photoelectric device can be made to operate as a micrometer for razor blades, wire, tube stock, and many other materials. A good example is its use in making precision measurements on piston rings. One light beam, directed at a phototube, scans the separation of the sample ring and a master. If the sample exceeds the

permitted tolerance, a rejection signal is operated. A mechanical shutter cuts off this beam as the piston ring gap is scanned. A second beam, scanning the gap, causes other rejection signals if the gap dimension is under or over tolerances. The entire inspection cycle requires less than 5 seconds.

#### Photoconductive Cells

The selenium cell is the most common photoconductive cell in modern usage. It is usually mounted in a glass container filled with an inert gas. Although used in conjunction with an amplifier in some cases, the photoconductive cell will pass sufficient current to operate a very sensitive relay directly. A relay having a winding resistance of 5000 to 10,000 ohms is frequently used in connection with these cells. When an amplifier is used with photoconductive cells, the choice of the grid resistance should depend upon the light resistance of the particular cell used, rather than being as high as possible, as with phototubes.

Fig. 7 illustrates the novel use of a self-generating selenium cell with a 1N34 germanium crystal rectifier to operate a rugged, less expensive relay. A small d.c. operating bias is provided by the crystal rectifier oper-

ated from the 6.3 volt winding of the filament transformer. This circuit is applicable to a wide variety of devices such as intrusion alarms, light-operated switches, garage door openers, etc. It is also used frequently in crowd-attracting window displays because of its simplicity and the fact that the absence of a high gain amplifier makes it immune to false operation by extraneous signals.

#### Photovoltaic Cells

Photovoltaic cells are most frequently used directly in series with a relay, meter, or other load. See Fig. 8. A simple photovoltaic cell consists of a lead electrode and an oxidized copper electrode immersed in an electrolyte. Exposure to light causes the cell to become a generator. Other "dry" photovoltaic cells consist of a sandwich of iron and selenium fitted with copper electrodes. Since such cells generate an emf., they require no external source of power. The copper oxide type of cell (Photox) has a color response almost identical with that of the human eye and hence is used in illumination control and in regulating industrial processes in which color or change of color of the product are important.

## Printed Electronic Circuits

THE reproduction of electrical circuits on insulated surfaces by various printing techniques has become a standard method of fabricating small, lightweight, economical electronic devices. The increased emphasis placed by the Armed Services and industry on miniaturization and ruggedness of electrical components has caused this innovation to assume vital importance. Printed circuitry is no longer confined to a few military devices and hearing aids, but may now be encountered in a large number of everyday equipments. These include speech amplifiers, portable receivers, citizens two-way radios, television receiver front-ends, FM receivers, and many others. For this reason, a working knowledge of the design, production, and maintenance of such circuits will be a valuable asset to any worker in the electronics field. This discussion is concerned with the general types of printed circuits, the relative advantages of each, and methods of effecting servicing repairs.

The use of printed circuitry has been revolutionary not only because

it permits the fabrication of extremely small and rugged electronic components, but also because it reduces the production of such components to a simple, rapid operation which is almost completely devoid of the possibility of human error. By this method, a relatively unskilled operator can reproduce literally hundreds of complex units in the time formerly

required to make one unit by old-fashioned "wire-by-wire" soldering techniques. In addition to electrical conductors, critical circuit components such as resistors, capacitors, and inductors can be "printed" into the circuit in the same operation and held to close, reproducible tolerances. Fig. 1 shows a typical printed circuit and its schematic diagram.

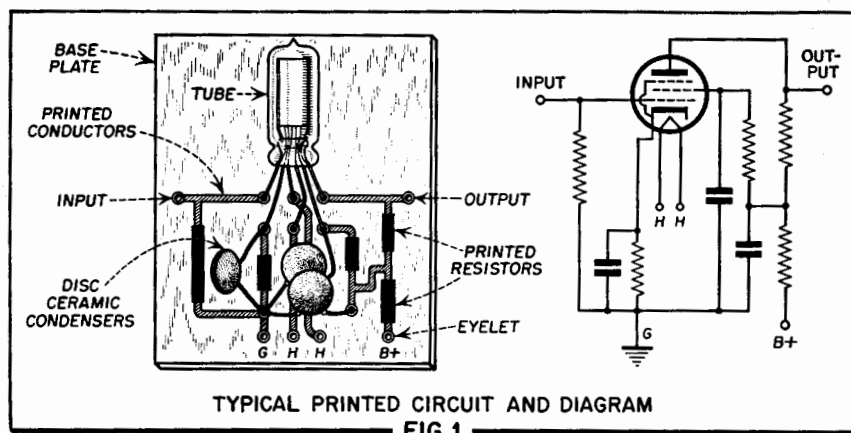

Printed circuits are classified according to the method used to reproduce them. There are, at present, six general types. These processes are: painting, spraying, vacuum evaporation, chemical processing, metal stamping, and powdered metal dusting. Each of these general categories will now be discussed in some detail.

#### Printing Techniques

Probably the most widely used process for producing printed circuits is the *painting* technique. In this method, the conductors and other components of the circuit being fabricated are painted on the insulating surface which acts as the base for the circuit. The paint may be applied by hand with a brush, although in production operations the silk-screen stenciling process is more frequently used. Thin ceramic or plastic sheets may be employed for the base, or a metallic surface covered with an insulating lacquer may be used. In special instances, the glass envelope of a vacuum tube has been utilized as a base for its associated printed circuit. See Fig. 2.

The paint used for electrical conductors consists of a powdered metal such as copper or silver in suspension in a liquid binder. This conducting paint is applied to the surface of the insulating base to form the "wires" of the circuit. Other paint, made up of a resistive material such as carbon, may be applied in specific amounts to form resistors. Capacitors may be made by printing the plates on opposite sides of the base plate, if the required capacitance is small. Otherwise, small capacitors are connected to the printed circuit as in Fig. 3. It is interesting to note that these capacitors are manufactured by processes which are essentially printed circuit techniques. Inductances are produced by painting spirals of conducting paint on the surface of the ceramic or other base material. "Crossovers" in the wiring are made by painting one conductor directly over the other with a layer of insulating material such as lacquer between, or by "detouring" one conductor to the other side of the plate for a short distance by means of metal rivets or eyelets through the insulator, as is illustrated in Fig. 4.

When all printed components have been painted in place, the entire assembly is "fired" at an elevated temperature to fuse the metal particles together and bond the circuit to the base plate. Temperatures ranging from room temperature for plastic bases to as high as 800 degrees C. for ceramics are used.

Vacuum tubes, external leads, and other components not printed are

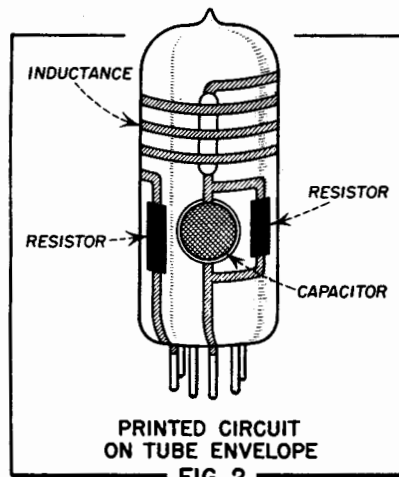

soldered to eyelets in the base plate as in Figs. 1 and 3. To take maximum advantage of the space-saving properties of printed circuits, tubes of the subminiature type are usually employed.

The painting technique has the advantage of requiring a minimum of auxiliary equipment and so has been the most popular type for experimentation and design work with printed circuits. It is also the best method to use in making repairs on printed circuits, as will be discussed later.

The *spraying* method of reproducing printed circuits differs from the painting technique in that the conductors are sprayed onto the surface of the base. Both molten metals and metallic conducting paints may be applied in this manner. In some processes, stencils are used to define the circuit conductors. In others, grooves are machined or molded in the base material where a conductor or other circuit component is desired. Grooves may also be formed by sand-blasting through a stencil. Metal is then sprayed over the entire base plate, filling the grooves and covering the spaces between. The surface is then milled off, removing the excess metal and leaving only that in the grooves. High conductivity is obtained by this method since relatively large conductors

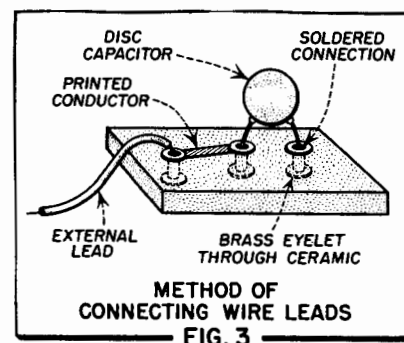

are formed in the grooves. Standard tube sockets and other components are sometimes connected to sprayed circuits by mounting them on the opposite side of the base plate so that the terminals protrude through holes into the grooves. Then, when the circuit is sprayed, connections are automatically made to the conductors. Circuit cross-overs are made in a manner similar to that employed in the painting process. Resistors, capacitors, and inductances may also be formed by spraying.

The *vacuum evaporation* process of circuit printing consists of evaporating a metal such as silver, copper, or nickel onto the surface of the dielectric material by melting the metal in a vacuum. A mask or stencil on the surface of the insulator is used to outline the circuit desired. In one such process, called "cathode sputtering", a high voltage is applied between the source of metal vapor (the cathode) and the work upon which it is to be deposited (the anode). The metal vapor is thus drawn to the work by electrostatic forces. Only a "rough" vacuum, such as can be produced by a good mechanical vacuum pump, is required for this process.

Another vacuum process used is very similar to cathode sputtering except that no voltage is applied between the cathode and the work. Metal evaporated from a heated filament, or other source of metal vapor, is distilled on the printed circuit plate placed over it. In either type of vacuum processing, it is unnecessary to further heat treat or fire the deposited metal. Only thin films are usually deposited in this manner. If greater conductivity is required, conductors may be built up by electroplating.

In the *chemical-deposition* methods of making printed circuits, the techniques employed are similar to those used in silvering mirrors. A silvering solution, consisting of ammonia and silver nitrate mixed with a reducing agent, is poured on the chemically clean surface to be coated. The confines of the solution are controlled by an adhesive stencil. The metal films obtained are usually too thin to permit direct soldering, but may be built up by repeated coatings or by plating. The chemical processes have not been applied as extensively as those discussed above.

The *metal stamping* technique has been used principally to print loop antennas on the back covers of radio receivers. However, other types of circuit wiring have been produced by this method. A die, bearing the outline of the desired circuit, is used to press a thin metal foil into the surface of a plastic or other insulator. In

the same operation the sharp edges of the die cut the metal sheet to the desired shape. The metal sheet may be backed by an adhesive to insure a good bond. Circuits made in this manner have good conductivity.

The last general type of printed circuit is produced by a process known as "dusting". In this method, a powdered metal is dusted onto the insulating base plate and fired in place. The circuit outline is defined either by coating the entire insulator with a sticky substance and applying the metal powder through a stencil, or by applying the bonding substance through the stencil and then dusting on the powder so that it is held in place by the adhesive until fired.

#### Serviceing Printed Circuits

As was mentioned above, the most convenient method of making repairs and replacements in printed circuits is the brush-applied painting technique. Kits of such paints, including both conductor and resistor mixtures, are commercially available. Most of these paints require no heat for drying, so that they may be used for repairing circuits having parts which cannot be subjected to high temperatures. This is an important precaution when working with circuits printed on certain types of plastic.

Although subminiature tube sockets are sometimes used with printed

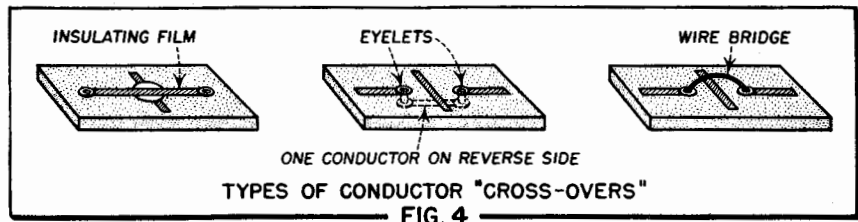

circuits, tubes are frequently connected directly to metal eyelets in the base plate, as in Fig. 1. When replacing tubes connected in this manner, care must be exercised to avoid the use of excessive heat during soldering operations. Soldered connections may also be made directly to printed conductors if the base material will stand the heat involved. A solder containing a small percentage of silver should be used for best results. Where soldering is inadvisable, connections to tube leads and other wires should be made with metallic paint.

Printed resistors which have become defective may be repaired or replaced by the painting technique. Defective resistors are located in the usual manner with an ohmmeter. If it becomes necessary to "disconnect" a printed resistor from the circuit for a resistance check, this may be accomplished by scratching through the printed conductor lead with a sharp instrument. If defective, the resistor

may be repaired with resistive paint. It will usually be found to be open or high in value. In such cases, additional resistive paint should be applied over the old resistor to reduce its resistance to the proper value. Some commercial printed circuits have a protective layer of lacquer over the conductors and particularly over resistors to prevent moisture absorption. This coating must be completely removed before repairing resistors. If attempts to repair defective resistors are unsuccessful, the old coating should be removed completely and a new resistor painted in its place. The proper dimensions may be determined by trial and error, keeping in mind that the resistance is directly proportional to the length, and inversely proportional to width and thickness. The resistance material must make good contact with the printed conductors at the ends. Breaks introduced in the conductors to isolate resistors may be repaired with a bridge of conducting paint.

## The Transistor - An Amplifying Crystal

AMONG recent technical developments, the "Transistor" or semiconductor triode, will probably have the most far-reaching effects upon every field of electronics. Although still in an embryonic stage comparable to that represented by the deForest "audion" in the development of the vacuum tube, the implications of this tiny, heaterless, vacuumless capsule are so tremendous as to warrant the interest of every worker in the radio field.

Just as the unidirectional conduction of current in the thermionic diode (Edison effect) was known for over 24 years before the addition of a third controlling element in the form of a grid, the rectifying properties of such semiconductors as galena, iron pyrites, silicon and germanium have been used in radio applications for many years. During this time very little thought was given to the possibility of electronically controll-

ing such rectification. However, due to impetus gained through the widespread use of crystals as microwave mixers and detectors during the last war, recent research in the field of semiconductors has resulted in the

discovery of the crystal triode, or Transistor.

Physically, the transistor consists of a conventional crystal diode such as was used in great numbers during the last war in radar receivers, modified only by the addition of a second "cat-whisker" contact. This makes contact with the germanium semiconductor at a point very close to the point of contact of the first cat-whisker, but is otherwise insulated from it. It is the addition of this element to the device which permits control of the current flowing to the first and enables it to perform many of the functions of a vacuum tube triode, although in a different way, as will be shown.

The construction of the transistor, as pioneered by the Bell Telephone Laboratories, is shown in Fig. 1. This mounting closely resembles the "coaxial cartridge" type commonly used in rectifier crystals, except that two

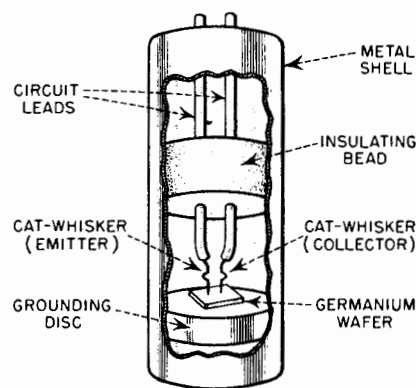
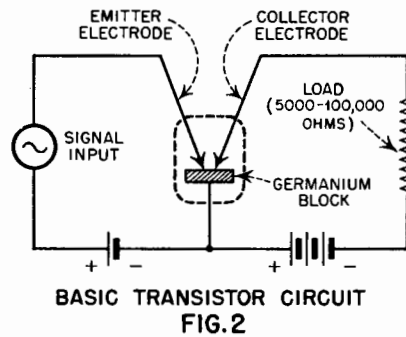

FIG. 1

center conductors are used. A small rectangular "wafer" of the semiconductor (germanium crystal) is soldered to a brass disc, which in turn is fitted into one end of a small metal tube approximately 3/16 inch in diameter and 3/4 inch long. Thus the device is comparable in size to a half-watt resistor. The two cat-whiskers are of tungsten wire approximately .002 inch in diameter welded to the ends of rigid wire terminals which in turn are spaced by an insulating bead. This supports them within the metal tube so that both cat-whiskers are brought into contact with the highly polished surface of the germanium. The separation between the points of contact is maintained at between .002 and .005 of an inch. The structure is ruggedized against mechanical shock and vibration by impregnating the capsule with a low-loss wax compound which also renders it moisture proof. It is probable, that, as the development of this mechanically simple device progresses, new applications will dictate radical departures from this preliminary design.

Experimental applications to which the transistor has been adapted include; radio-frequency amplifier stages, audio and r.f. oscillators, intermediate frequency amplifiers, audio amplifier stages and other types of circuitry now commonly employing vacuum tubes. As yet, the upper frequency limit of the transistor is about 10 megacycles per second, but there appears to be no fundamental reason why this range of usefulness cannot be extended into at least the VHF region to include television and f.m. applications. However, transit-time effects, inherent in semiconductor devices as in negative-grid vacuum tubes, will probably limit operation beyond the VHF range. Although diode crystal rectifiers are efficient as detectors and converters of microwave energy at frequencies exceeding 25,000 megacycles/second, the type of high-inverse-voltage germanium semiconductor used in the present transistor is not an efficient rectifier at frequencies much above 60 megacycles/sec.

Another limitation to the use of the transistor in some circuit applications is the excessive noise voltages generated within it at present. This noise is about 70 d.b. above the theoretical thermal or *Johnson Noise*, which is defined as the noise that would be generated in an equivalent resistance due to the random motion of thermally agitated electrons within it. This objectionable noise characteristic is most pronounced at the audio frequencies and appears to decrease somewhat with frequency.



Future laboratory work will undoubtedly result in methods of reducing such noise to more usable levels. If noise figures comparable to those encountered in the modern vacuum tube are achieved, the transistor will replace tubes in many low-power applications, since it consumes no heater or filament power, requires no warm-up time, is virtually heatless in operation and is more compact and rugged than even the subminiature vacuum tubes. Because of these advantages, transistors will find use in circuits where economy of power consumption and extreme compactness are desirable. Such circuits may include ultra-portable broadcast receivers using printed wiring and components, electronic computing devices which may require as many as 18,800 vacuum tubes (as in the ENIAC), electronic musical instruments which also use hundreds of vacuum tubes operating at low audio levels and other more conventional applications. The mere fact that the transistor does not require a vacuum is an important advantage, since the production and maintenance of a satisfactory high vacuum is an item of major expense in the manufacture of electron tubes. In addition, the operating efficiency of the transistor exceeds that of vacuum tubes in many applications, especially when it is considered that no heater power input is required. Operating efficiencies as high as 25%

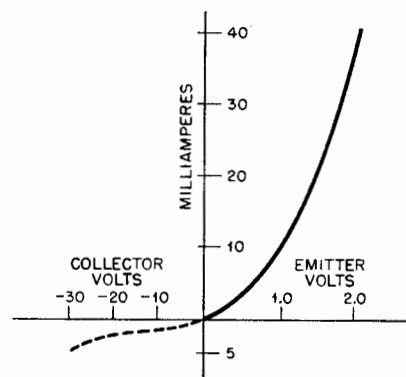

FIG. 3

have been observed at output levels of from 10 to 20 milliwatts.

The basic electrical circuit of the transistor is shown in Fig. 2. The input electrode, which is called the "emitter," is maintained at a small positive potential with respect to the germanium block. The impedance to current flow in this direction is low (100-400 ohms) due to the rectifying action of the germanium-tungsten contact. Therefore, this small positive "bias" voltage (.1 to .5 volt) causes an appreciable "forward" current to flow in the emitter circuit. Also, because of this low impedance to forward currents, a small increment in emitter voltage caused by an impressed signal will result in a large increase in electron current flowing from the semi-conductor to the cat-whisker. The static voltage-current characteristic of the emitter circuit, when considered alone, is similar to that of the typical germanium point-contact rectifier, which is shown in Fig. 3. On the other hand the "collector," or output contact of the transistor, is biased negatively with respect to the germanium. At this polarity, the impedance to current flow is relatively high (exceeding 10,000 ohms), so that over 30 volts may be applied to the collector before appreciable "back" current flows in the semiconductor. The dotted portion of Fig. 3 represents the static (no load) characteristic of the collector circuit in the absence of the emitter. The close proximity of the two cat-whiskers with their respective operating voltages modifies these characteristics considerably, however. It is the ability of the transistor to transfer an emitter voltage change to the collector circuit in the form of a resistance change, which gives the device its name, which means **TRANSFER RESISTOR**. This property results in effective power gains of 100 times or 20 db being possible.

To understand the mechanism whereby emitter circuit power variations induce relatively larger power variations in the collector circuit and hence, enables the transistor to amplify, it is necessary to examine the fundamental properties of semiconductors. Although the theory of the transistor is still not completely understood and may be subject to frequent revision, a working concept of its operation can be gained from a simplified analysis and by drawing analogies to vacuum tube circuits.

It will be recalled that the resistance properties of substances depend on the number of free electrons available in the molecular structure for the conduction of current. In some



materials the electrons in the outer "shells" or orbits of the atoms are so loosely bound to the nuclei that they are easily removed and may move about between atoms under the influence of thermal agitation. If an external stimulus is applied, such as the connection of a battery across such a material, the random motions of these free electrons within it are coordinated into a unidirectional current flow. The metals, which may have as many as one or two free electrons per atom, are examples of such materials which are good conductors of electricity. Other substances, on the other hand, may have virtually no free electrons available for current conduction and so are classed as insulators. The semi-conductors are intermediate between metals and insulators in the scale of conductivity, having perhaps only one free electron for every million atoms. The extent and type of current conduction possible within them is dependant upon the very minute quantities of impurities present. Thus, although perfectly pure germanium, (if obtainable), would be a very poor conductor at normal temperatures, the addition of quantities as small as .001 percent of tin or some other impurity provides enough free carriers for conduction to be possible. The word "carriers" is used here since current in a semiconductor can be carried in two distinctly different ways; by the presence of free electrons within it, or by the absence of some of the "bound" ones. The latter type of conduction the solid-state physicist has termed "conduction by holes." These "holes" are vacancies in the otherwise filled lines of valence electrons which make up the interatomic bonds of the crystal, and they constitute *virtual* positive charges. They may move along in a random manner by being filled in by an adjacent electron, which in turn leaves a "hole" behind it. Thus, the process continues with the "hole" moving at rather high speed through the crystal as the atoms attempt to maintain equilibrium between themselves. If a voltage is applied across such a semiconductor, the holes, being positive in nature, are attracted to the negative electrode instead of to the positive electrode as is the case of free electrons. Whether a semiconductor conducts by the extra negative electron process (n-type), or the "positive hole" process (p-type), depends on the kind of impurity added. Thus, silicon "doped" with aluminum or boron impurity is a p-type semiconductor, while silicon containing minute quantities of phosphorus is an n-type. If the added impurity atom has one less valence electron

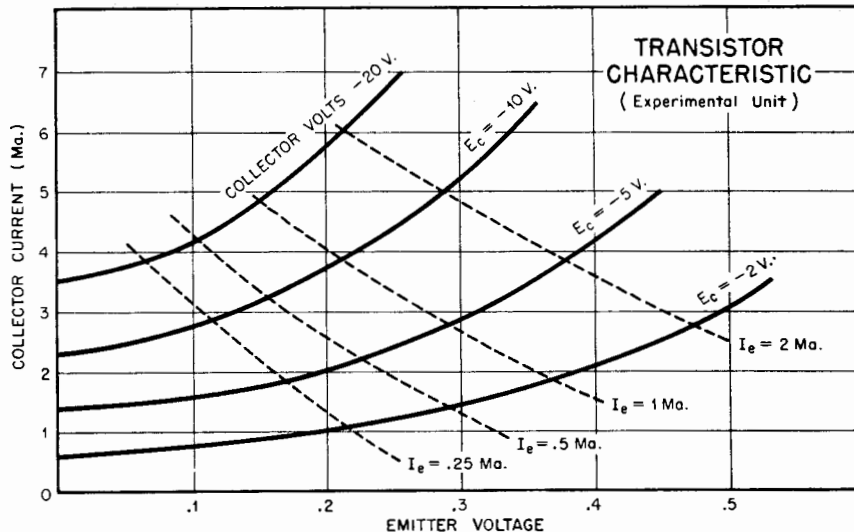

FIG. 4

than the semiconductor atom, a p-type ("hole") semiconductor results. If it has one more valence electron, an n-type crystal results. The type of conduction in germanium can also be changed by heat-treatment.

In the transistor, both n-type and p-type current conduction are present. The emitter is biased positively so as to attract free electrons which surmount the rectifying barrier layer at the interface of the semiconductor-to-metal contact and flow in the input circuit. The collector, biased highly negative, attracts a small number of "holes" in the absence of emitter current. The useful property of the transistor arises from the fact that a flow of electron current to the emitter cat-whisker causes the formation of many more electron vacancies or "holes" at the surface of the semiconductor which are gathered by the nearby collector cat-whisker. The result is an increase of output current. A change in the emitter circuit current "modulates" the number of "holes" available to the collector and thus causes a similar change in collector current. Although the current changes in the input and output circuits are of similar magnitude, amplification results since the collector circuit impedance is approximately 100 times that of the emitter circuit. Fig. 4

shows the way in which the collector current and emitter current vary with emitter voltage at given value of collector voltage.

A vacuum tube circuit which has characteristics closely analogous to the action of a transistor is shown in Fig. 5. In this circuit the transistor is replaced by a dual-diode vacuum tube which contains a small quantity of residual gas. The two small anodes are spaced close together and are biased by voltages of similar polarity to those applied to the two contacts of the transistor. The anode which is at a small positive potential with respect to the cathode has characteristics which are comparable to the emitter electrode; it attracts electrons from the cathode and thus its circuit presents low impedance to "forward" current flow. The diode plate which is biased negatively is analogous to the collector cat-whisker of the transistor in that the circuit impedance is very high and little current flows in it normally. However, the flow of current in the "emitter" may be made to increase the current flowing in the collector circuit. Electrons being accelerated toward the emitter anode may collide with residual gas molecules, remove electrons from them, and thereby form positive ions which are drawn to the negative collector anode. These ions are roughly analogous to the "holes" in the transistor case since they behave like positive particles and move more slowly than electrons. The number of ions formed depends upon the number of electrons flowing to the emitter anode. Therefore, the input circuit controls the flow of current in the output circuit, just as in the transistor and conventional vacuum tube amplifiers.

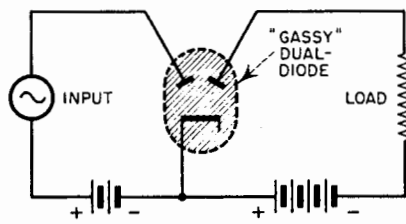

FIG. 5

The advent of the transistor opens fertile fields for future development. Much remains to be done in the adaptation of conventional circuitry for use with this simple device. Problems frequently arise since the electrode voltage polarities and circuit impedances differ so greatly from those encountered in vacuum tubes.

The cascading of amplifier stages is complicated by the fact that the input and output impedances do not lend themselves well to the usual schemes of interstage coupling. The possibility of push-pull and paralleled units for increased power output is still to be fully exploited.

Because of its simple structure

and the small amount of test equipment required, the transistor provides a valuable subject for individual experimentation. Transistors have been fabricated for study purposes from germanium removed from standard 1N34 diode crystal rectifiers suitably mounted with two adjustable fine wire cat-whiskers.

## Junction Transistor Circuits

THE former tightness of the transistor situation has been eased favorably for the non-military experimenter and manufacturer by the present excellent availability of the new junction-type transistors. The lower price of these components, compared with the almost prohibitive price of the earlier point-contact transistors, should stimulate private development of transistor circuits. It is expected that prices will drop further in proportion to the number of circuit applications which can be developed to utilize the wide spread in coefficients resulting in transistor manufacture.

The circuits included in this discussion have been made to work satisfactorily and can be duplicated. It should be borne in mind, however, that these circuits satisfied one set of typical conditions and do not necessarily represent the best or only way of applying the transistor for the purpose intended. Considerable flexibility in individual design is possible. In addition, some readjustment of constants may be required when transistors of various manufacturers are used. The circuits described are intended especially for junction-type transistors and some of them often will not operate equally well with point-contact triodes. In presenting this material, we feel that it will be invaluable in guiding the newcomer to transistor circuitry and will be of provocative importance as well.

### Features of the Junction Transistor

Several characteristics of the junction transistor distinguish it from the point-contact type. One of the most important of these is the increased ruggedness of the junction type. In the junction transistor, the three conduction layers (P, N, and P in the case of the CK722) are parts of the same germanium wafer. There accordingly are no whiskers or sandwich sections which might be displaced accidentally.

A dramatic property of the junction transistor is its high efficiency

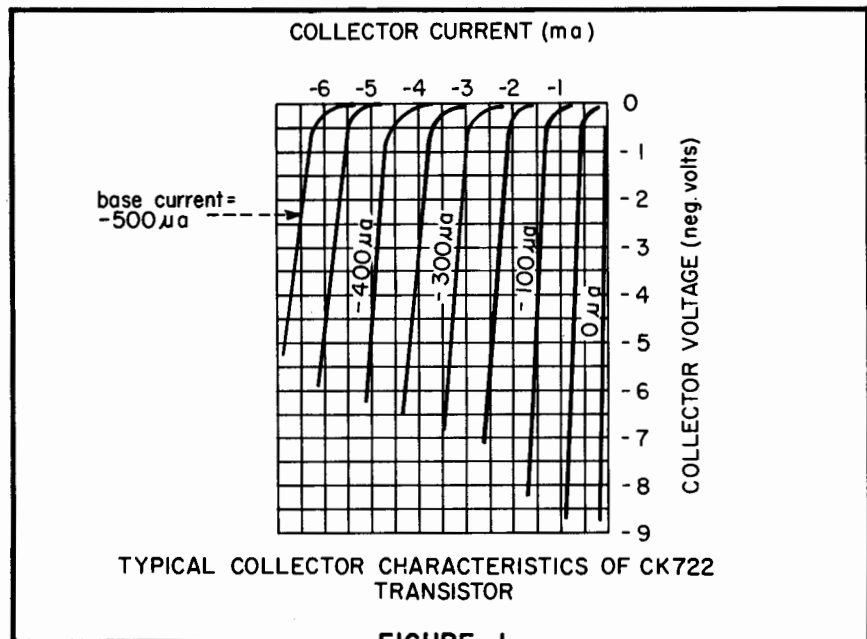

### CK722 OPERATING DATA

#### ABSOLUTE MAXIMUM RATINGS

Collector Voltage ( $V_c$ )	-20 volts
Collector Current ( $I_c$ )	-5 ma.
Collector Dissipation	30 mw. at 30° C.
Emitter Current ( $I_e$ )	5 ma.
Ambient Temperature	50° C.

#### TYPICAL GROUNDED-EMITTER AMPLIFIER CHARACTERISTICS

Collector Voltage ( $V_c$ )	-1.5 volt
Collector Current ( $I_c$ )	-0.5 ma.
Base Current	-20 $\mu$ a.
Current Amplification Factor ( $\beta^*$ )	12
Power Gain	1000 (30 db.) Source 1000 ohms; Load 20,000 ohms.

Noise Factor 22 db. at 1000 cycles

\*This rating applies only to the grounded-emitter circuit. The current amplification factor  $\alpha$  for the grounded-base connection is, of course, less than 1 for the junction transistor.

Figure 2

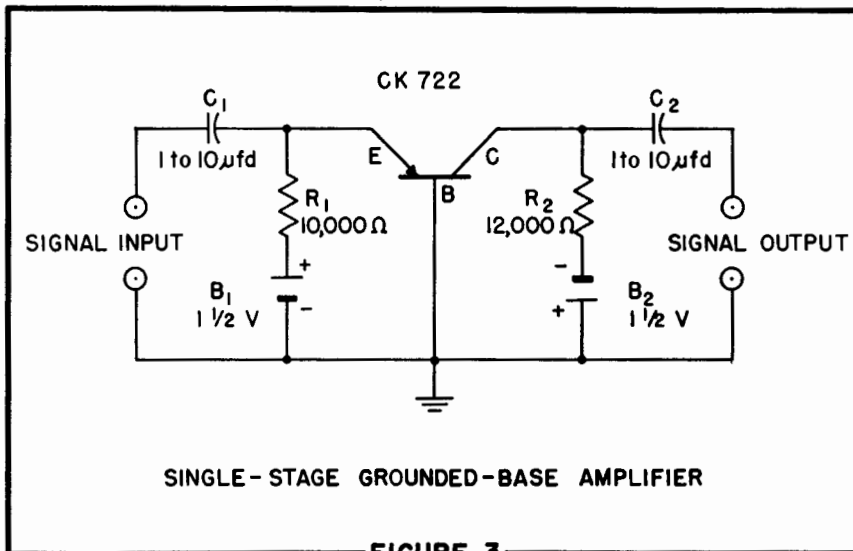

FIGURE 3

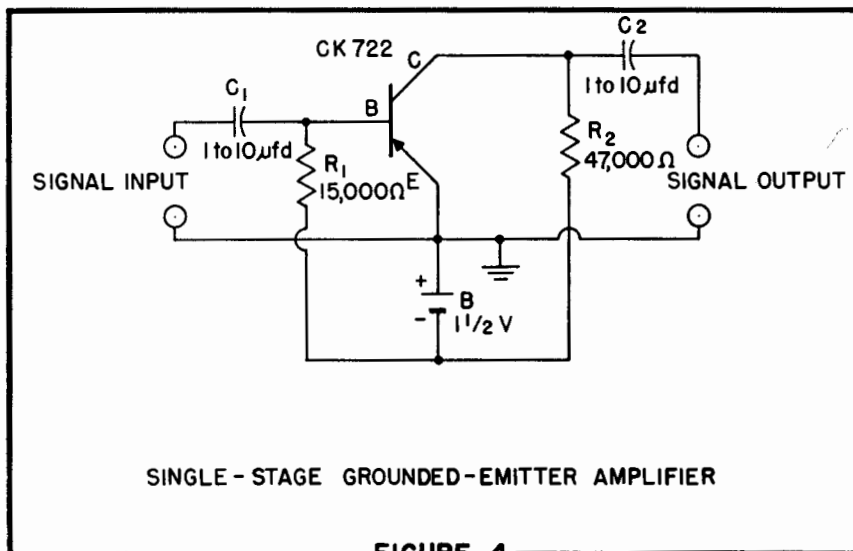

FIGURE 4

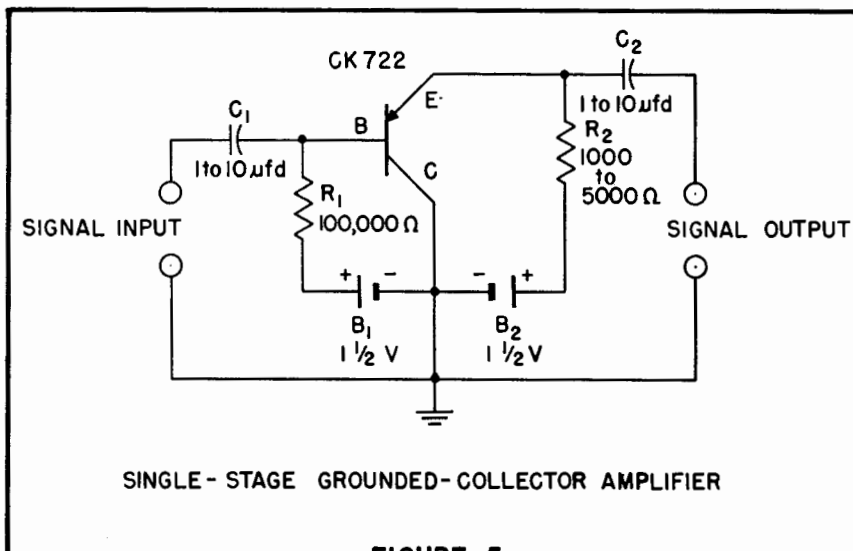

FIGURE 5

and its ability to operate at very low values of applied d.c. voltage. A class "A" amplifier using a junction type, for example, will operate close to the theoretical 50% efficiency point, as compared with a vacuum-tube amplifier giving 25 to 30 percent. Practical amplifiers and oscillators can be operated from a single 1½-volt cell with current drains so low that in some arrangements the cell will give shelf life. Audio oscillators can be made to operate at such low d.c. levels that, in demonstrations, the "power supply" current has been furnished by a self-generating photocell, thermocouple, or makeshift wet cell made from two coins separated by a piece of paper moistened with saliva.

The temperature sensitivity of the junction transistor makes the latter somewhat poorer than the point-contact type, but the junction type is not as noisy. The maximum ambient temperature allowed for the CK722 is 50°C. The 1000-cycle noise factor is 22 db. (Compare the noise factor of 65 db, which is given for the CK716 point-contact transistor).

Frequency response of the junction transistor appears to be lower than that of the point-contact type and is limited by such factors as the increased capacitance of the junction layers and the differences in mobility of the carriers. Our tests indicate that the CK722 is suited particularly to audio and *low-frequency* r. f. applications, of which there are many in each category. As a radio-frequency oscillator, this unit has given good performance in our circuits as high as the upper limit of the standard broadcast band, but beyond that point its operation has not been encouraging.

Figure 1 shows a family of collector current-vs-collector voltage curves for the CK722. These curves are plotted for eight values of constant base current (0, 50, 100, 200, 300, 350, 400, 450, and 500 microamperes). Note that these curves have the general appearance of pentode vacuum-tube curves. The collector voltage ( $V_c$ ) values are negative. The corresponding collector currents ( $I_c$ ) also are designated as negative.

The Table in Figure 2 lists important operating data for the CK722. One listing is apt to confuse the reader who has had some prior contact with transistor literature. This is the current amplification factor, always mentioned as less than unity for junction transistors, which is given here as 12. The reason for this higher figure is that the factor given in Fig-

ure 2 is not  $\alpha$  (which is less than 1) but  $\beta$  which applies only to the grounded-emitter (base-input) operation shown. Beta ( $\beta$ ) is related to  $\alpha$  ( $\alpha$ ) approximately as follows:  $\beta = 1/(1-\alpha)$ .

#### Junction Triode Circuits

Figures 3 to 9 show several selected amplifier and oscillator circuits. These preliminary circuits can serve as building blocks for more complex equipment. Note that each of these arrangements uses the low d.c. voltages at which the junction transistor is capable of operating.

**Single Amplifier Stages.** Figure 3 is a resistance-coupled, grounded-base audio amplifier circuit. The grounded-base arrangement is the progenitor of all transistor circuits.

The grounded-base circuit has an input impedance of approximately 1000 ohms and an output impedance of 5000 to 10,000 ohms, depending upon individual transistor collector characteristics. Higher operating impedances are possible in the output with higher  $R_2$  values, but with somewhat reduced gain. Operating into a high-impedance load (100,000 ohms or higher), this stage, as shown, has a voltage gain of 40, although the gain may vary between 36 and 44 with individual transistors. At lower load resistance values, the gain drops proportionately.

With 1-microfarad input and output capacitors ( $C_1$  and  $C_2$ ), the frequency response is such that the gain at 100 cycles is 25% of the 1000-cycle value, and at 20,000 cycles is 92% of the 1000-cycle value. With 10-microfarad capacitors, the 20-cycle gain is 67% of the 1000-cycle value, and the 20,000-cycle gain 98% of the 1000-cycle value. Miniature, low-voltage electrolytic coupling capacitors may be used for the high values.

Because the grounded-base amplifier requires two batteries, there is some objection to its use. Current drain of the emitter battery is 150 microamperes, and of the collector battery 100 ua. The grounded-base amplifier offers the maximum power gain possible with a given transistor.

Figure 4 shows a grounded-emitter amplifier. An important advantage of this circuit is its ability to operate with a single battery at a drain of 10 to 80 microamperes, depending upon the individual transistor employed. Input impedance is of the order of 1000 ohms; output impedance 20,000 to 40,000 ohms. Higher output impedance values are possible with higher values of  $R_2$  but with reduced gain.

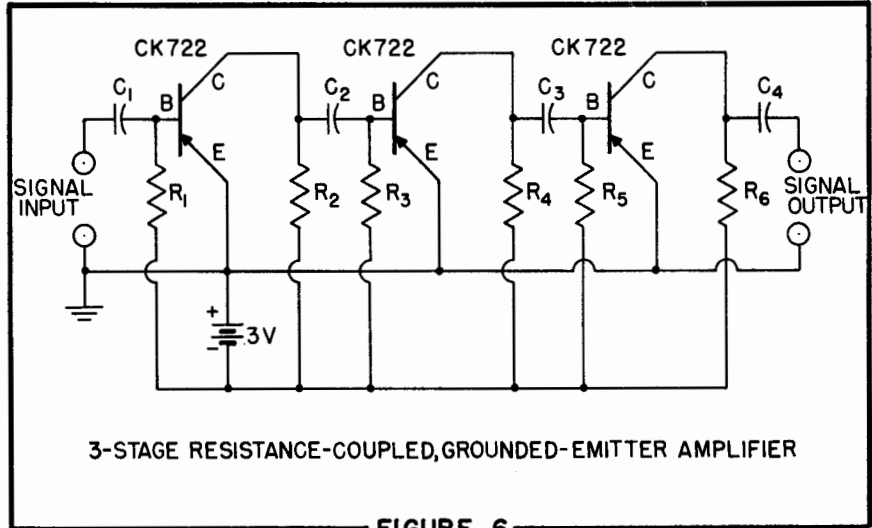

FIGURE 6

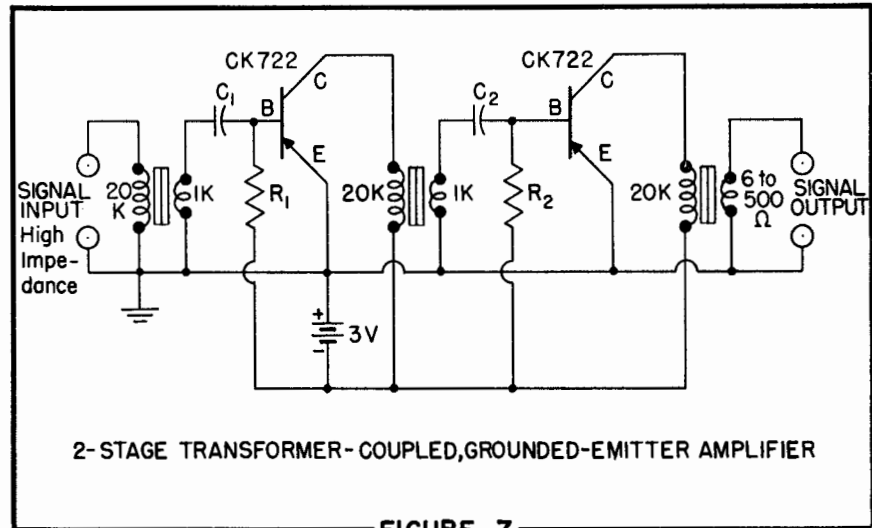

FIGURE 7

With the constants given in Figure 4, voltage gain of this stage is 40 to 50 when  $B$  is 1½ volt, and 80 to 100 when  $B$  is 3 volts. These gains are obtained only when the stage is worked into a high load impedance (100,000 ohms or higher).

Frequency response is the same as that quoted for the grounded-base amplifier in the foregoing paragraphs.

Figure 5 shows a grounded-collector amplifier. This circuit has high input impedance (of the order of 50,000 ohms) and low output impedance, 1000 ohms. It thus is equivalent to the cathode-follower vacuum-tube amplifier. Like the cathode follower, the grounded-collector circuit provides no voltage gain ("gain" of the stage shown in Figure 5 is 0.2 to 0.3). It does afford power gain, however, of the order of 15. The frequency response of this stage is the same as

that stated earlier for the grounded-base circuit.

A slight disadvantage of the grounded-collector type of circuit is its requirement of two batteries ( $B_1$  and  $B_2$ ). But its relatively high input impedance suits it very well to use as the input stage of a transistor amplifier whenever the loss in voltage gain is of no consequence.

We did not discover that bypassing either of the power supplies in any of the circuits shown offered improvement in performance at any frequency between 20 cycles and 20 kc.

#### Cascaded Amplifiers

The circuits given in Figures 3 to 5 are fundamental building blocks. Like tube circuits, transistor amplifier stages may be cascaded for increased voltage gain and power gain. The difference with transistors, how-

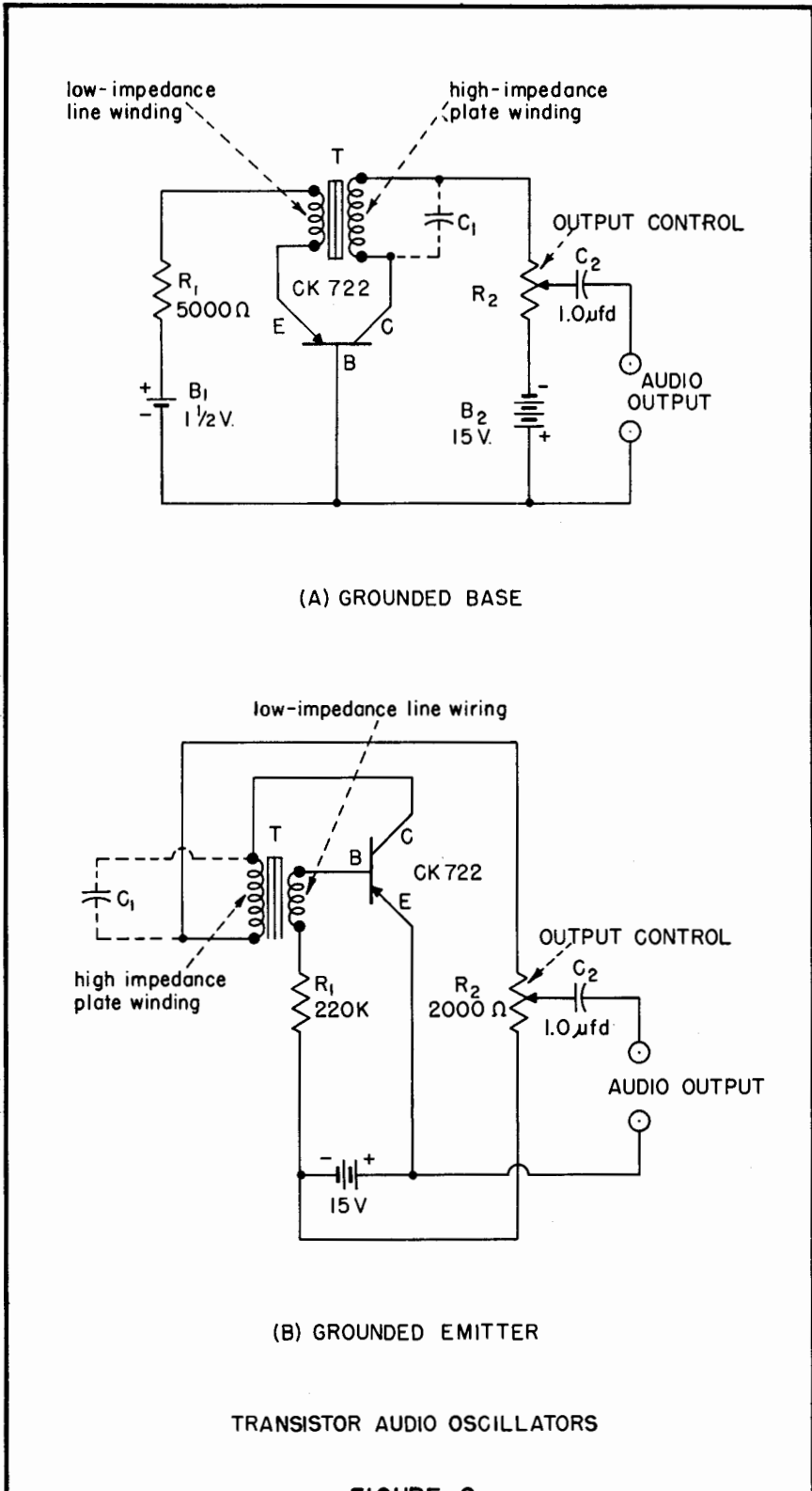

(A) GROUNDED BASE

(B) GROUNDED EMITTER

TRANSISTOR AUDIO OSCILLATORS

FIGURE 8

since the latter has the lower step-down ratio and offers best power transfer. In resistance coupling, at least one additional transistor stage usually is necessary to provide the same overall power gain afforded by transformer coupling.

Figure 6 shows one method of resistance-coupling three junction transistor stages. Overall power gain is approximately 60 db. Collector resistors  $R_2$ ,  $R_4$ , and  $R_6$  each is 20,000 ohms. Base resistors  $R_1$ ,  $R_3$ , and  $R_5$  each is 150,000 ohms. For best results, each of these resistors should be adjusted carefully for the best gain and lowest noise output with the individual transistors used. Capacitors  $C_1$ ,  $C_2$ ,  $C_3$ , and  $C_4$  each is 10 microfarads. This amplifier will deliver approximately 2½ milliwatts output to a high-impedance load. A 1000- or 2000-ohm headphone may be connected in place of  $R_6$  and  $C_4$  to obtain approximately the same output in such applications as hearing aids, pocket radio receivers, etc.

Figure 7 shows a transformer-coupled 2-stage transistor amplifier. This unit has an overall power gain of approximately 50 db. The interstage transformers have primary impedances of 20,000 ohms each, and secondary impedances of 1000 ohms each. For experimental setups, good results can be obtained with carbon-microphone transformers connected backward. The output transformer has a 20,000-ohm primary. Its secondary may have the proper value required to match a small loudspeaker, headphones, line, or other device. If desired, a 1000- or 2000-ohm headphone may be connected in place of the primary of the output transformer,  $T_3$ . Suitable subminiature transformers for use in the transistor amplifier intended for hearing aids, pocket receivers, are available at most parts distributors. A high-impedance crystal microphone may be coupled into the first transistor by using a 200,000- to 1000-ohm input transformer at  $T_1$ .

In Figure 7, capacitors  $C_1$  and  $C_2$  each is 10 microfarads. Resistors  $R_1$  and  $R_2$  each is 150,000 ohms.

Using the fundamental building blocks, a number of combinations of cascaded amplifier stages is possible to suit individual requirements. For example; grounded-base, grounded-emitter, grounded-collector, resistance-coupled, and transformer-coupled stages may be combined, as needed.

Transistor Oscillator Circuits

The CK722 junction transistor appears to oscillate most readily in an

ever, rests in the fact that in grounded-base and grounded-emitter stages, the output impedance is higher than the input impedance. This requires an impedance stepdown between

stages. While resistance coupling may be employed as well as transformer coupling between stages, the greater power gain will be obtained with interstage transformer coupling,

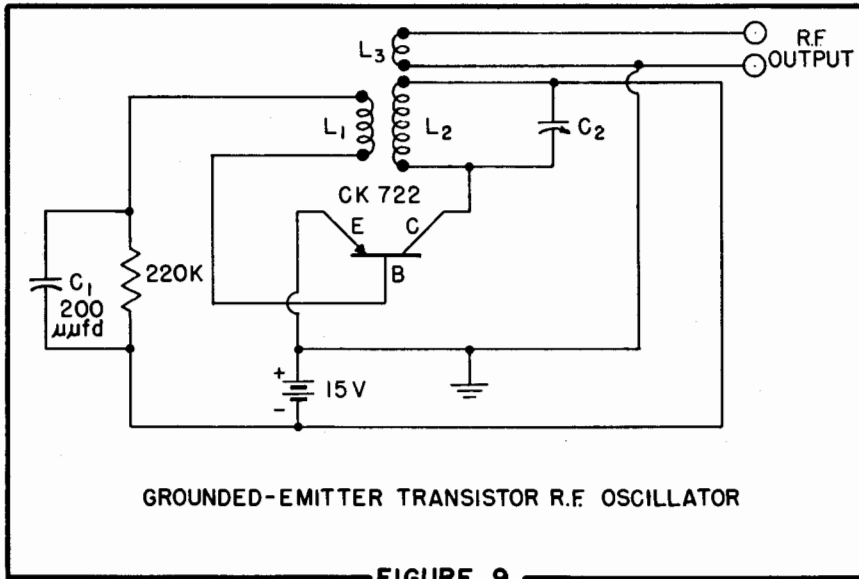

FIGURE 9

inductive-feedback type of circuit. Figure 8 shows two audio-frequency oscillators employing this principle. Figure 9 is a radio frequency oscillator employing inductive ("tickler") feedback.

Audio transformers are used in Figure 8 (A) and 8(B). In each instance, the high-impedance winding is connected to the collector. A satisfactory transformer is the type used to couple a single triode plate to 500- or 600-ohm line. Satisfactory results may be obtained also with a carbon-microphone transformer. The transformer must be phased properly for oscillation. If oscillation is not obtained immediately upon application of battery voltage, reverse the con-

nections of either the primary or secondary. With a microphone transformer at T in each circuit, a 700-cycle signal was generated. The "natural" frequency will depend upon the inductance of the windings and their distributed capacitance, and may be lowered by means of capacitors connected at C<sub>1</sub>.

Figure 8 (A) shows a grounded-base oscillator; Figure 8 (B) a grounded-emitter oscillator circuit. The first circuit requires two batteries but is somewhat less temperature-sensitive than the second.

Air-wound coils are used in the radio-frequency oscillator, Figure 9. The top frequency at which this cir-

cuit has been operated with the CK722 is 1500 kc. No frequency data are published on this transistor.

Tight coupling is employed between coils L<sub>1</sub> and L<sub>2</sub>, the former being wound on top of the latter. The output coupling coil, L<sub>3</sub>, is wound on the same form close to L<sub>2</sub>. By making these coil sets plug-in, frequency bands between 50 and 1500 kc. may be covered.

A good broadcast-band oscillator may be made with L<sub>2</sub> a 540-1750 kc. antenna coil. L<sub>3</sub> is the slip-on primary normally supplied with the antenna coil. L<sub>1</sub> consists of 75 turns of No. 30 enamelled wire closewound on top of the manufactured coil L<sub>2</sub>. Coil L<sub>1</sub> is insulated from L<sub>2</sub> with Scotch tape. C<sub>2</sub> is a 365-uufd. tuning capacitor.

An interesting regenerative broadcast receiver having good sensitivity can be made by connecting antenna and ground to the two terminals of L<sub>3</sub>, and a pair of 2000-ohm (or higher, magnetic) headphones in series with the collector and L<sub>2</sub>. Regeneration can be controlled by means of a 1-megohm potentiometer substituted for the 220,000-ohm fixed resistor shown in Figure 9. A transistor audio amplifier may be added by substituting the amplifier input transformer for the headphones. Near the vicinity of strong local stations, an outside antenna and ground are not required, an ac-dc antenna hank, connected to one terminal of L<sub>3</sub> being sufficient. The other terminal of L<sub>3</sub> then would be connected to positive terminal of the battery, as shown in Figure 9.

## Class-B Transistor Amplifier Data

THE transistor is an efficient device by nature. Even when we fail to take into account the absence of filament power, the transistor is found to offer higher operating efficiency than the vacuum tube. This is especially true of the junction transistors.

In transistor amplifiers, as in tube amplifiers, higher efficiencies are made possible by class-B operation. There are two main reasons for the present growing interest in class-B transistor operation. First, class-B gives maximum output watts per dollar of initial cost — an important consideration when utilizing present, high-priced power transistors. Sec-

ond, the rather low power output of conventional transistors may be boosted several times by utilizing class-B.

### Class-B Tube vs Transistor

In a conventional class-B tube amplifier, the control grids are biased for plate current cutoff, or very nearly so, under zero-signal conditions. The plate current then is driven to a certain peak value at maximum signal. Large economies are effected by the low, resting, no-signal d. c. plate power input.

There are two ways of adjusting a transistor amplifier for class-B operation. Under zero-signal con-

ditions, the output electrode (usually the collector) may be operated either at low direct current and high voltage (comparable to static operation of the class-B tube amplifier) or at high direct current and low voltage. In the first instance, the input a. c. signal will drive the output-electrode direct current upward. In the second case, it will drive the current downward.

The family of common-emitter collector curves in Figure 1 will serve to illustrate this point. When the circuit is adjusted for no-signal operation at  $v_{1i2}$ , the resting point is X. The positive half-cycle of the input signal then will drive the collector

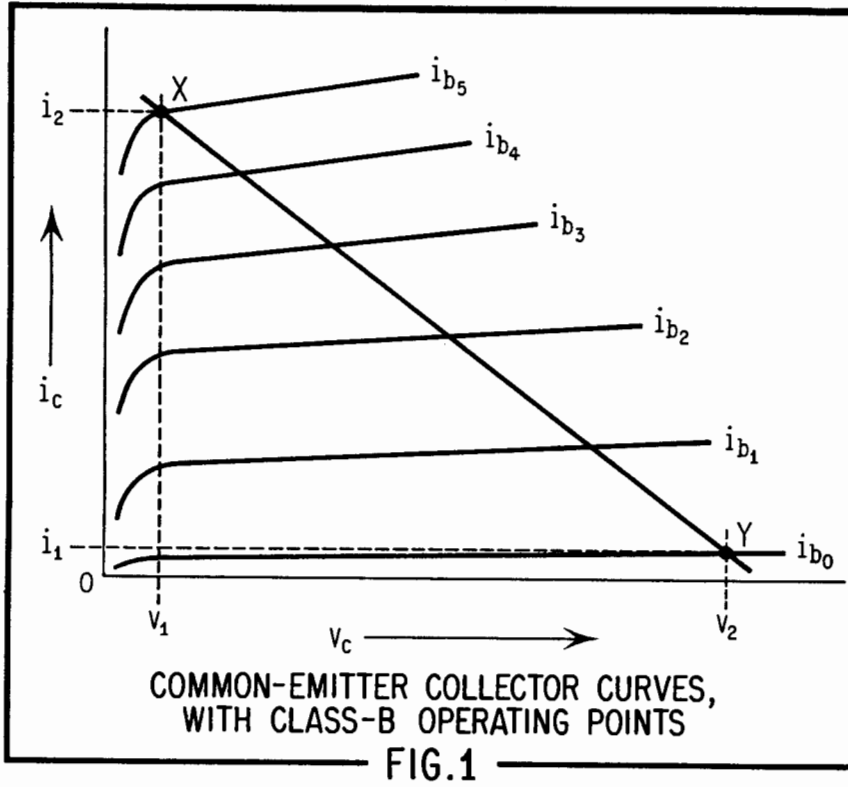

current from  $i_2$  down to  $i_1$ , and the operating point to Y which corresponds to  $v_2 i_1$ . When, instead, Y is chosen as the no-signal operating point corresponding to  $v_2 i_1$ , the *negative* half-cycle of the input signal will drive the collector current up from  $i_1$  to  $i_2$ , and the operating point to X which corresponds to  $v_1 i_2$ .

While both operating points ( $v_1 i_2$  and  $v_2 i_1$ ) can represent points of low "resting" collector dissipation, the greater overall operating economy is afforded by the high-voltage, low-current condition (Y,  $v_2 i_1$ ). This is because the establishment of the opposite condition, a low collector voltage at high current from a constant-voltage collector d. c. supply would necessitate use of a dropping resistor with attendant IR loss. Large initial collector current also reduces the transistor current amplification factor, alpha.

As in the class-B tube amplifier, dynamic output-electrode current in the transistor class-B amplifier becomes a series of quasi half-sinusoids. Thus; in the common-emitter circuit with static characteristics such as displayed in Figure 1, the half-sinusoids of collector current would extend from the "zero" value,  $i_1$ , to the peak value,  $i_2$ , and back.

Figure 2 shows a comparable family of curves for the common-base transistor amplifier configuration.

Note the general similarity to the family in Figure 1, but the increased linearity due to the more even spacing of the common-base curves. In the common-base circuit, collector current is driven upward from point Y by positive half-cycles of emitter

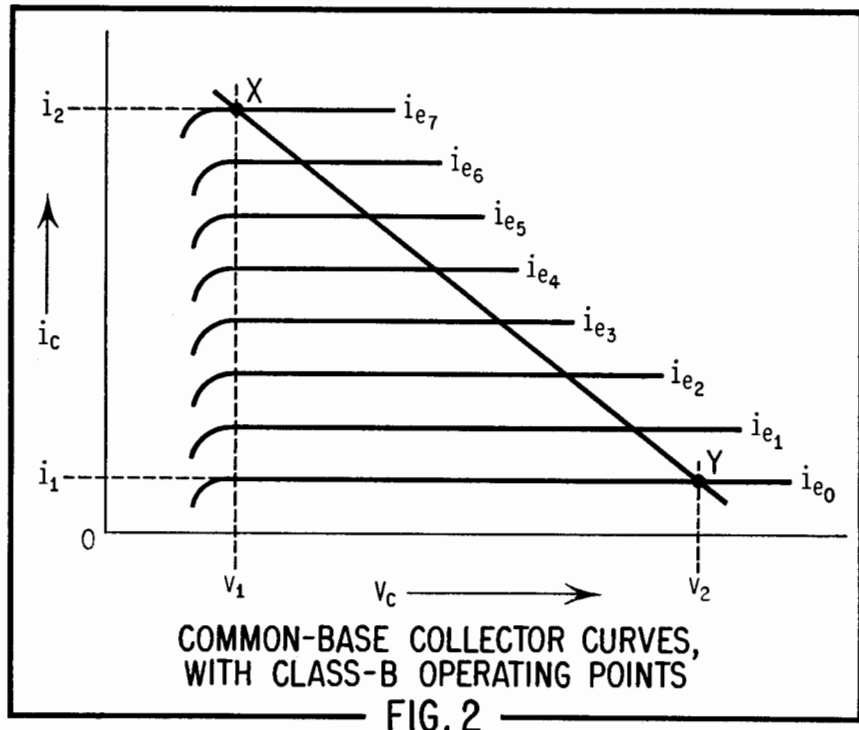

signal voltage, or downward from point X by negative half-cycles of emitter signal voltage. This is the opposite of conditions with the common-emitter configuration.

*Circuit Configurations*

Transistors must be used in push-pull pairs in class-B amplifiers, the same as in comparable tube amplifiers. However, the distortion reducing properties of the symmetrical arrangement are somewhat less in the transistor circuit. Either of the three well-known transistor circuit configurations may be employed: common-base, common-emitter, or common-collector.

D. C. output-circuit efficiency runs close to 80 percent for each circuit. Power gain is highest with the common-emitter, less by a factor of 10 with the common-base, and quite low (of the order of 10) with the common-collector. However, the common-base configuration affords the highest power output and overall power gain, for a given distortion level. The output vs distortion ratio is due to its more favorable  $v_c$ - $i_c$  characteristic.

Figure 3 shows typical circuit arrangements for the three configurations. While batteries are shown for simplicity, the bias voltages may be obtained likewise from a. c. — operated power supplies.

The currents and voltages  $i_b$ ,  $i_c$ ,  $i_e$ ,  $v_b$ ,  $v_c$ , and  $v_e$  are d. c. or peak

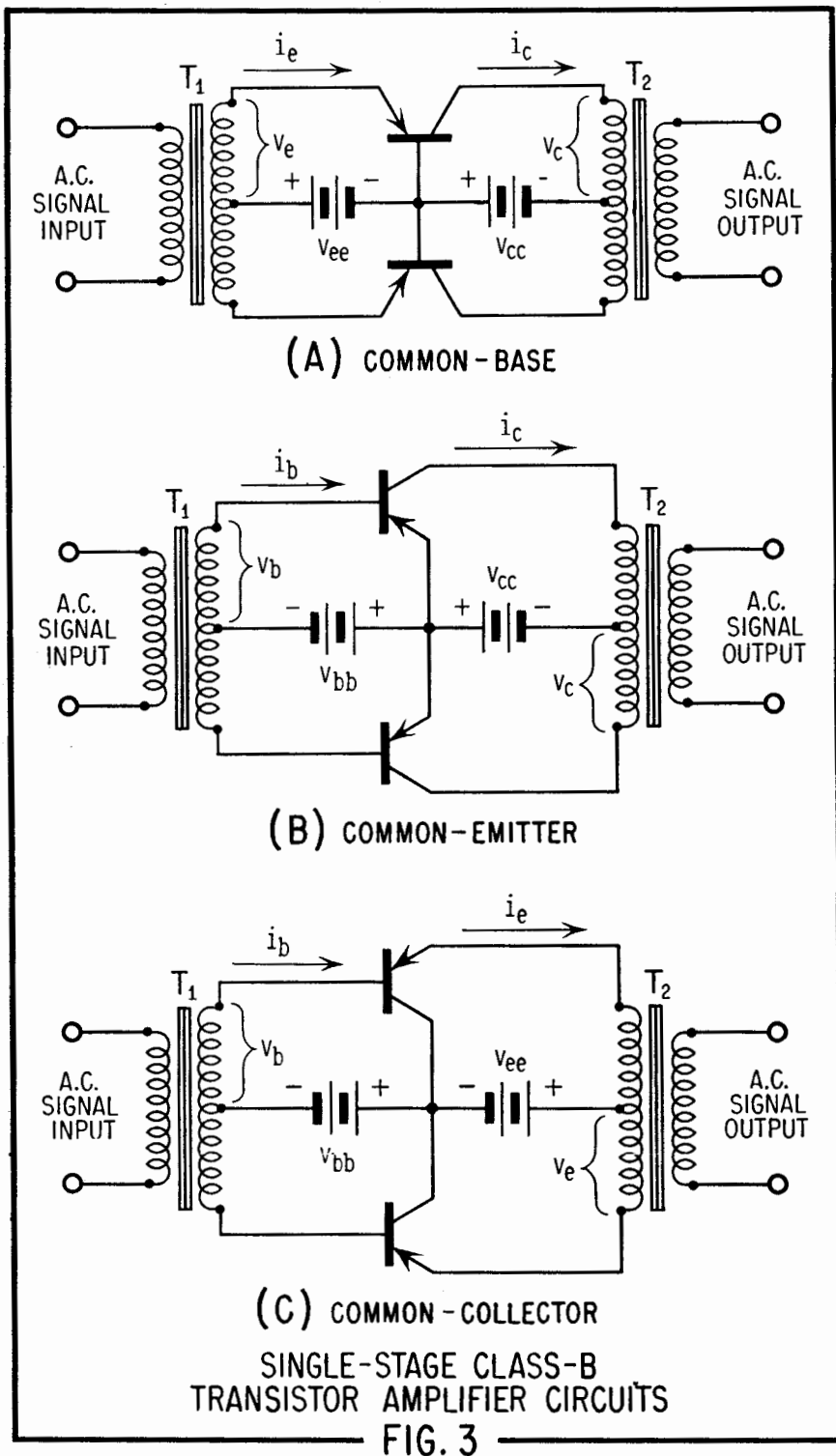

values obtained from the static characteristic curves of the transistor employed. For example; in the common-emitter circuit (Figure 3B),  $i_c$  corresponds to collector current  $i_c$  at point X in Figure 1, and  $i_b$  to the constant base current  $i_{b_0}$  in Figure

1. The base voltage ( $v_b$ ) and emitter voltage ( $v_e$ ) must be determined experimentally for the particular transistor employed, since most transistor manufacturers do not now supply input characteristic curves. This

is done by finding the base voltage in a common-emitter circuit which will produce base current value  $i_{b_0}$  (Figure 1) or the emitter voltage which will produce emitter current  $i_{e_0}$  (Figure 2). In each case, it is assumed that collector current is held constant at value  $i_c$  (Figures 1 and 2) during the measurement.

#### Design and Operating Data

After selecting the type of junction transistor to be used and obtaining a pair matched for  $v_i$ - $i_c$  characteristics and alpha, the first requirement is choice of collector supply voltage,  $v_{cc}$ . This voltage must not exceed one-half the maximum permissible peak inverse voltage specified by the transistor manufacturer.

In most applications, the common-emitter circuit will be employed, because of its superior power gain. The maximum collector supply voltage then corresponds to  $v_c$  in Figure 1, and this value is to be  $\frac{1}{2}$  the maximum peak inverse. The point X must be selected such that the product  $v_c i_c$  does not exceed the maximum permissible collector d. c. power dissipation specified by the transistor manufacturer. The primary winding of the output coupling transformer,  $T_2$ , is assumed to have low d. c. resistance, in order to minimize voltage drop between  $v_{cc}$  and the collector.

The following approximate common-emitter class-B design equations have been adapted from those given by Shea. Currents  $i_b$  and  $i_c$  (both in amperes) and voltages  $v_b$  and  $v_c$  (both in volts) are maximum-signal peak values. Values are for two transistors, except where noted otherwise.

- (1) D. C. Collector Power Input =  $(v_c i_c) / 1.57$  watts
- (2) Peak A. C. Power Output =  $(v_c i_c) / 2$  watts
- (3) Peak A. C. Driving Power =  $v_b i_b$  watts
- (4) Load Resistance =  $(4v_c) / i_c$  ohms (collector-to-collector)
- (5) Input Resistance per transistor =  $v_b / i_b$  ohms =  $(4v_b) / i_b$  ohms base-to-base

If  $i_c$  (Figure 1) is taken as the peak value of the zero-signal collector current and  $i_c$  as its maximum-signal peak value, the maximum-signal average value of the d. c. collector current for each transistor, as read with a d'Arsonval-type d. c. milliammeter in series with the collector is:



(6)  $i_c$  avg. = 0.318 ( $i_c$ ) amperes  
Power gain for the common-emitter stage is:

(7)  $PG = (Bv_{ce})/v_b$ , where B is the grounded-emitter current amplification factor (beta) of the transistor used.

Input and output transformers ( $T_1$  and  $T_2$ , respectively) are chosen

to match the transistor input and output impedances obtained by means of Equations (4) and (5). To minimize d. c. voltage drops, the secondary of  $T_1$  and the primary of  $T_2$  must have low d. c. resistance.

A satisfactory practical method of checking performance with calculated circuit values utilizes an oscilloscope to measure peak values of

input and output signal voltages, and heavily-bypassed d. c. milliammeters to check  $i_b$  and  $i_c$  values. The sinusoidal input-signal voltage is increased slowly from zero, while monitoring the waveform of both input and output voltages for peak amplitude (not in excess of transistor dissipation rating) and distortion. A satisfactory frequency for class-B audio tests is 1000 cycles.

## Load Lines In Transistor Amplifier Design

GRAPHICAL constructions are of considerable aid in designing electron tube circuits. Load lines drawn across the plate current-vs-plate voltage family of curves yield circuit constants and important operating data. This relatively simple procedure eliminates many tedious calculations.

Graphical constructions are equally useful in the design of transistor amplifier circuits. Similar advantages are obtained. In transistor work, load lines are constructed on the collector  $v_{ce}$  family of curves to determine operating point, load resistance, distortion, collector current swing, and base current values. The technique is similar in every respect to that employed in tube work.

In this discussion we will show, by illustrative examples, how to use the load line technique in transistor amplifier design.

### DETAILED PROCEDURE

Figure 1 shows the circuit of a typical common-emitter, RC-coupled transistor amplifier stage. The common-emitter, also sometimes called the *grounded-emitter*, is widely used because it affords high power gain, high voltage gain, 180-degree phase reversal similar to a tube, and good frequency response.

When the constants of this circuit, especially the load resistance ( $R_L$ ), collector supply voltage ( $v_{ce}$ ), and collector-to-emitter voltage ( $v_{ce}$ ) are chosen in such a way that the internal parameters of the transistor determine largely the operating point of the amplifier, inefficient operation, high distortion, or poor instability usually result. By proper choice of the operating point with respect to the transistor characteristics and supply voltage, low-distortion class-A performance easily is obtained safely

within the transistor maximum ratings.

For graphical construction, the first requirement is to obtain a set of collector EI curves, such as those in Figure 2, for the transistor chosen. For common-emitter operation, the family contains a separate curve for each of several typical base-current values and is a plot of collector-to-emitter voltage,  $v_{ce}$ , versus collector current,  $i_c$ . If such a set of curves is not available in the transistor manufacturer's literature, the operator must plot a set by making a series of common-emitter d-c measurements on the particular type of transistor which is to be used in the amplifier. The procedure is to set the base bias current at a given level (zero base current is one such level) and to vary the collector current (supplied by a constant-current supply) while observing the corresponding voltage between collector and emitter.

In the graphical construction, follow this procedure: (1) Label the points of maximum collector current and maximum collector voltage on the graph. Figure 2 is a family of curves for the Raytheon CK721 transistor. The maximum collector current, from the manufacturer's data sheet, therefore is —10 ma, as labelled in Figure 2, and the maximum collector voltage is —22 volts. (2) Draw across the curves a plot showing the current and voltage intersects for the maximum dissipation ( $P_c$ ), in watts recommended by the manufacturer. In the case of the CK721,  $P_c = 33$  milliwatts and is represented by the dashed line which bends across the collector family in Figure 2. At any point of intersection of this line with abscissae and ordinates, the product  $v_{ce}i_c = 0.033$ . In determining the points for the dissipation curve, voltages may be selected along the hori-

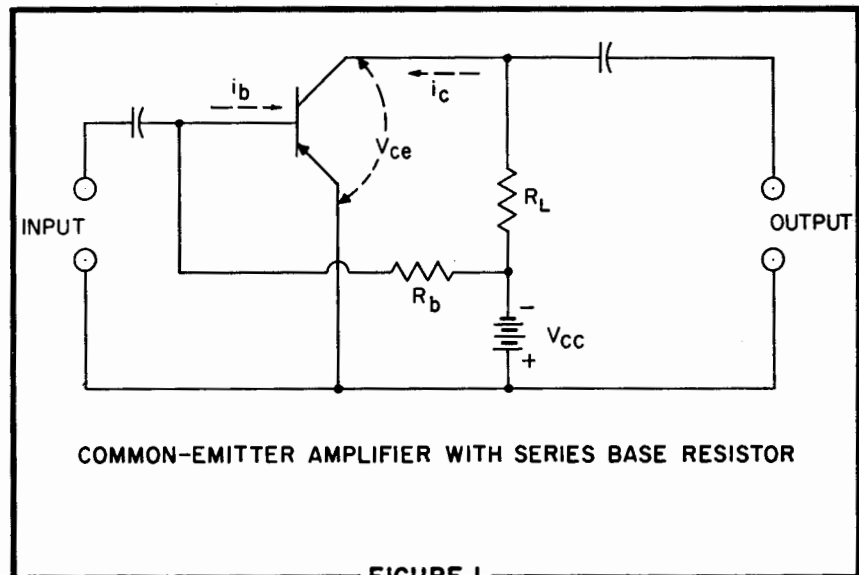

FIGURE 1

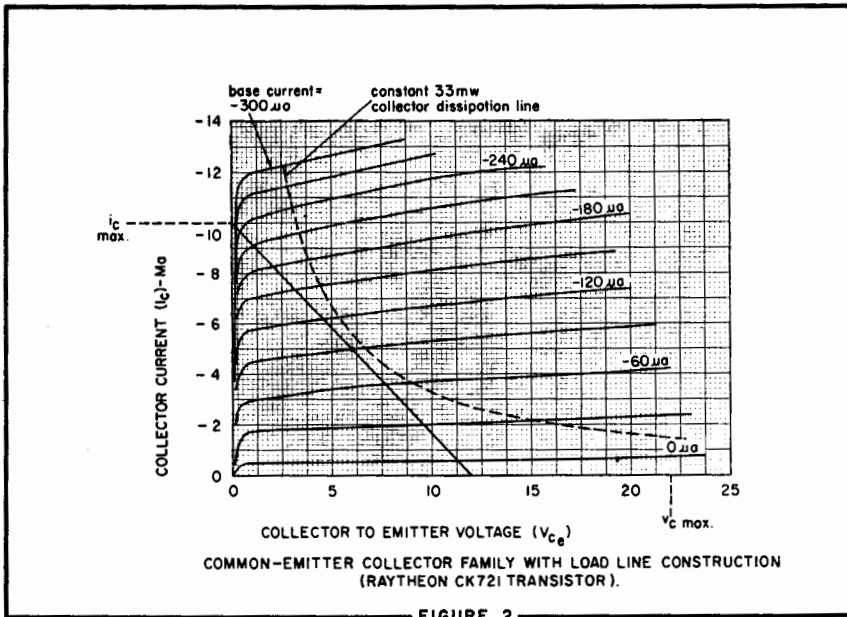

FIGURE 2

zontal axis and corresponding current values calculated ( $i_c = P_c/v_c$ ), or current points may be selected along the vertical axis and corresponding voltage values calculated ( $v_c = P_c/i_c$ ). The area of the graph below and to the left of this curve encloses all points which are within the dissipation rating of the transistor. All points in the area above and to the right of this curve represent overload and must be avoided. (3) Select the operating point of the transistor (that is, collector voltage and collector current) and the supply voltage. (4) Mark the operating point on the graph. Example, see the dot at the intersection of the 6-volt and 5-milliampere lines in Figure 2. (5) Con-

struct a load line from the supply voltage point on the horizontal axis, through the operating point, to the vertical axis. This is the solid line in Figure 2. (6) Determine the required load impedance,  $R_L$ , by computing the slope of the load line. ( $R_L = dv_c/di_c$ ).

Several facts are evident from an examination of Figure 2, a typical example of transistor load line application. (a) The operating point has been selected at  $v_{ce} = 6$  v,  $i_c = 5$  ma. (b) With a supply voltage of  $-12$  v, the load line extends from  $-12$  to  $-10$  ma. The load resistance accordingly is  $dv_c/di_c = (0-12)/(0-0.01) = 1200$  ohms. (c) The entire load line is seen to be within

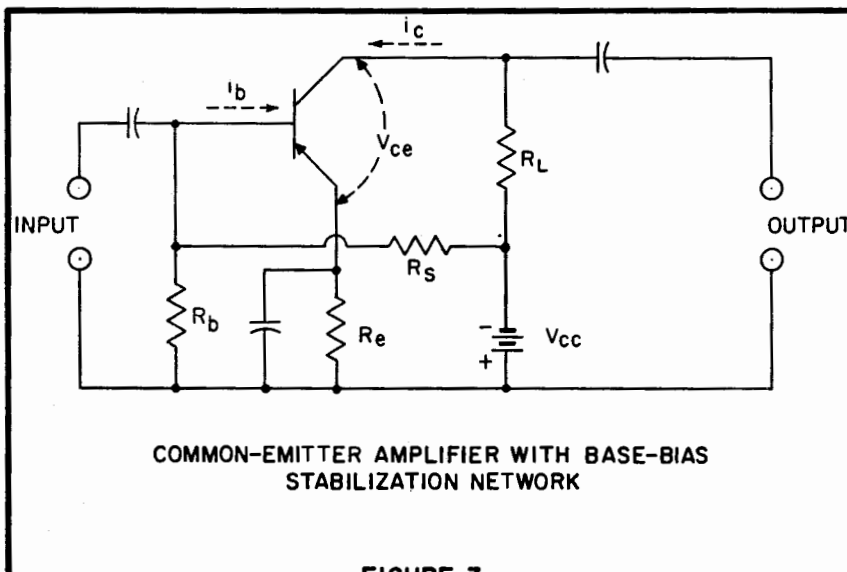

FIGURE 3

the dissipation rating of the CK721, being 3 milliwatts lower than the constant dissipation curve at the point of closest proximity. (d) The base current level which will bias the transistor for the 5 ma. collector current at the operating point is seen to be 90 microamperes.

In the preceding example, the supply voltage was assumed fixed. The operating point was chosen, and the required load resistance determined from the slope of the load line. It is easily seen that different procedures might stem from other combinations of known and unknown factors. For example, the operating point and load resistance might be given and the required supply voltage left to be determined, or the load resistance and supply voltage might be specified and the operating point placed at any satisfactory position along the resulting load line.

It is desirable that the collector signal-voltage swing encompass as much of the collector characteristic as is feasible. This will insure maximum output voltage. Thus, with the operating point set at 6 v, 5 ma in Figure 2, the collector signal voltage may swing down the load line to the  $0 \mu a$  base-current curve and up the load line to the  $210 \mu a$  base-current curve without encountering the severe bending at the left ends of these curves. However, it is obvious that the upper swing traverses a larger number of base-current curves than the lower swing, because of the progressively closer spacing of the curves at the higher base current levels. The asymmetry of signal waveform due to this condition may be minimized by limiting the swing to the region of more nearly equal base-current curve spacing, when low distortion is a more important objective than maximum output.

The collector current at the operating point is a function of the base bias current,  $i_b$ . Reference to Figure 2 shows that  $i_b$  must be 90 microamperes when  $R_L = 1250$  ohms and  $v_{cc} = 12$  volts. This base bias current may be obtained from a separate battery or from  $v_{cc}$  through a series dropping resistor,  $R_b$  in Figure 1. Base bias also may be obtained from a voltage divider ( $R_s/R_b$ ), operated from  $v_{cc}$ , and an emitter series resistor,  $R_e$ , as in Figure 3. The required value of series resistor,  $R_b$ , in Figure 1, may be determined from the simple relationship  $R_b = v_{cc}/i_b$ , where  $R_b$  is in ohms,  $v_{cc}$  in volts, and  $i_b$  in amperes. For the 90-microampere base current indicated in Figure 2,  $R_b = 12/(9 \times 10^{-5}) =$

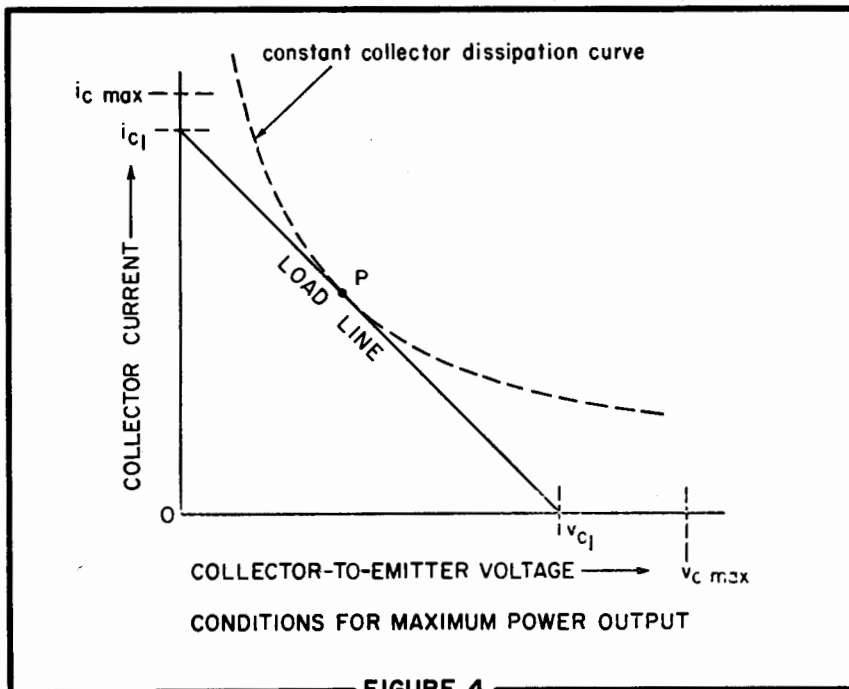

FIGURE 4

133,500 ohms. In this calculation, the internal base-to-emitter resistance  $r_{be}$  of the transistor is ignored, since its magnitude is very small with respect to  $R_b$ .

There is some objection to using series-resistor base bias in the common-emitter circuit in the way shown in Figure 1, because the high external resistance,  $R_b$ , in the base circuit tends to free the transistor for rather wide shifts of the operating point resulting from the effects of temperature on the internal parameters of the transistor. The base

biasing scheme illustrated in Figure 3 overcomes this difficulty, stabilizing the operating point against temperature changes as well as against variations between individual transistors. In this arrangement, the supply voltage,  $v_{cc}$ , is reduced by the divider network,  $R_2R_b$ , and this lower potential is presented to the base of the transistor. Resistor  $R_e$  in series with the emitter then limits the base current to the desired bias value.  $R_e$  is bypassed heavily to minimize the effects of degeneration. Current through the  $R_2R_b$  leg is chosen high enough that

resistances  $R_2$  and  $R_b$  may be made small with respect to the internal resistances of the transistor. This circuit satisfies the condition for stability that any external resistance in the base lead must be small and any external resistance in the emitter lead be made as high as possible.

### MAXIMUM POWER OUTPUT

For maximum power output, a condition extremely important in the operation of conventional transistors since their power output capabilities normally are low compared to tubes, the load line should enclose as large an area as possible within the maximum current, voltage, and power dissipation ratings of the transistor.

Figure 4 illustrates the condition for maximum power output, although not necessarily at low distortion. The known supply voltage value,  $v_{c1}$ , as located along the horizontal axis. A load line then is drawn from  $v_{c1}$  to the vertical axis so as to be tangent to the constant collector dissipation curve at a single point, P. The load line intersects the current axis at  $i_{c1}$ . Both  $i_{c1}$  and  $v_{c1}$  are seen to lie within the maximum ratings ( $i_{cmax}$  and  $v_{cmax}$ ). The slope of this line ( $v_{c1}/i_{c1}$ ) yields the load resistance.

### CLASS-B POWER AMPLIFIERS

The use of load lines in the determination of driving and output conditions, load resistance, and operating characteristics of transistorized Class B amplifiers has been previously discussed under the heading of Class-B Transistor Amplifier Data. To avoid repetition here, the reader having need of this data is referred to that discussion.

## Simple, Inexpensive Geiger Counters

**L**IGHTWEIGHT, portable radioactivity detecting instruments presently are in demand both for prospecting and for civil defense stocks. Although small Geiger counters are available commercially in a variety of types and over a wide price range, many electronic technicians and engineers will elect to build their own.

The technician has a number of circuits from which to choose. The beginner undoubtedly will select the simpler ones. A simpler instrument also will be the logical choice for the person having no interest in uranium prospecting but wanting to keep a Geiger counter handy for probable

civilian emergency use. In such an emergency, such as might follow a bombing, the radioactivity level would be expected to be high, and the high sensitivity of more complicated instruments not needed. The more serious uranium prospector would seek the higher sensitivity of the more complex circuits. In any event, the technician who builds his own Geiger counter expects that, in addition to the education and enjoyment secured from the work, his instrument will cost him less than a comparable manufactured one.

We will present here a representative group of simple Geiger counter circuits.

These circuits have been tested. All frills have been eliminated in order to obtain foolproof operation and to insure that any reasonably competent technician might duplicate the instruments successfully with ordinary tools and equipment.

The counter tubes used in the circuits shown here are Victoreen Types 1B85 and 1B86. Tubes having equivalent electrical characteristics also may be employed. The 1B85 requires a d-c operating voltage of 900 v. Its threshold voltage is 800 v, and its minimum plateau length 200 volts (plateau slope 3%/100 v). Its life is  $10^8$  counts. The 1B86 requires a d-c operating voltage of only 300 v.

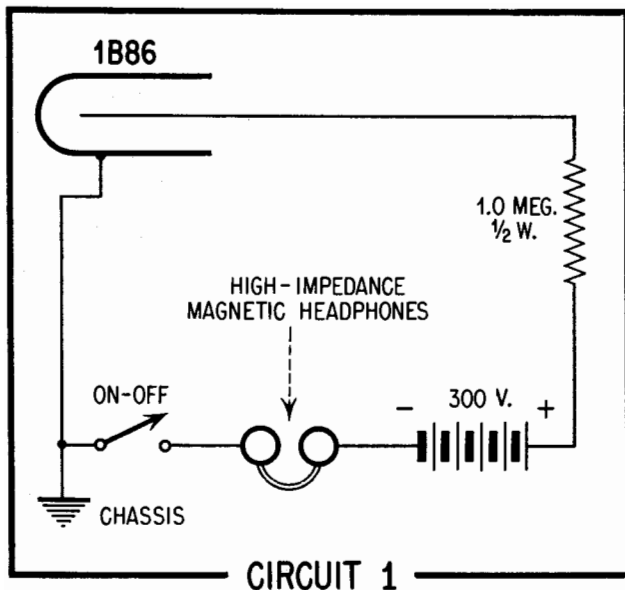

CIRCUIT 1

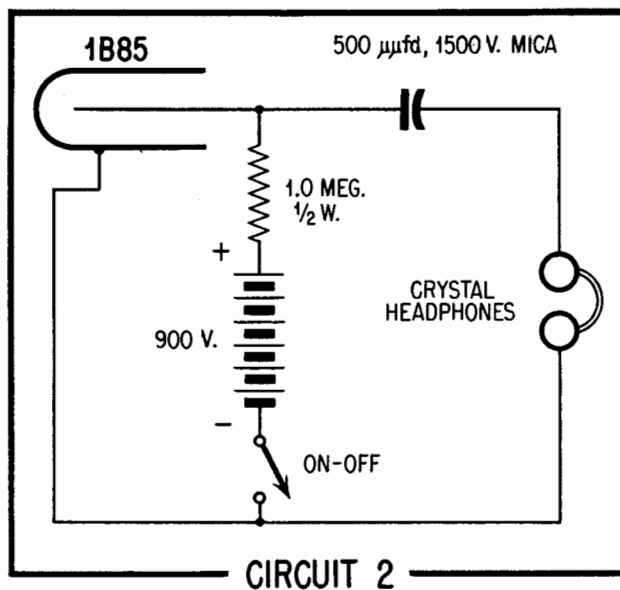

CIRCUIT 2

Its threshold voltage is 280 v, and its minimum plateau length 60 volts (plateau slope 30%/50 v). Its life is  $5 \times 10^7$  counts. The counter tube may be operated in a probe on the end of a shielded cable, or it may be installed inside the instrument case, with a suitable opening, holes, or louvers for entry of radiant energy.

Basically, the differences between Geiger counter circuitry result from (1) the method of obtaining the high voltage for the counter tube, (2) whether amplification is employed, and (3) whether indications are aural, visual, or both.

#### Typical Circuits

Eight representative Geiger counter circuits are shown. These are discussed separately in the following paragraphs.

**Circuit 1.** This is the simplest possible arrangement. Here, a 1B86 counter tube is connected in series with a miniature 300-volt battery (similar to Burgess U200 or RCA VS093), headphones, and a 1-megohm current-limiting resistor. A spst switch allows the circuit to be disabled when not in use.

Each ionizing particle penetrating the counter tube causes a pulse of current to flow through the circuit, and this produces a click in the headphones. In order to complete the circuit, the headphones must be of the magnetic type and must have high impedance. A stepdown matching transformer would be required for low-impedance headphones. Crystal-type headphones, although possessing

remarkably high impedance, are unsatisfactory in this circuit because they provide no continuity for dc.

The 1B86 is a glass-wall gamma ray tube. Its diameter is 0.4 inch and its over-all length, including its  $1\frac{1}{8}$ " tinned leads, is  $4\frac{3}{4}$  inch. For more compact assembly or smaller-sized probes, Type 1B88 counter tube may be substituted. The latter also has a diameter of 0.4 inch, but its over-all length (including  $1\frac{1}{8}$ " tinned leads) is only  $2\frac{3}{4}$  inches.

The 300-volt Type U200 battery measures  $2\text{-}11/16"$  x  $2\text{-}7/32"$  x  $3\text{-}29/32"$ .

**Circuit 2.** The sensitivity of the simple, battery-operated counter may be improved by employing a general-purpose betagamma counter tube, such as Type 1B85, with a 900-volt d-c supply. The high voltage is obtained from three miniature 300-volt batteries (such as specified for single use in Circuit 1) connected in series. Circuit 2 shows this arrangement.

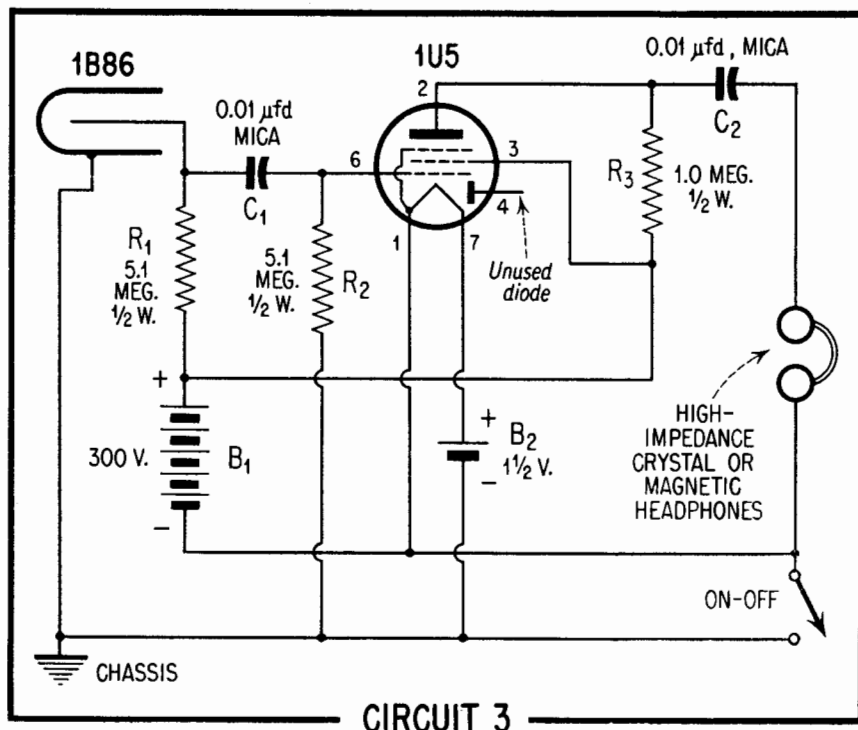

CIRCUIT 3

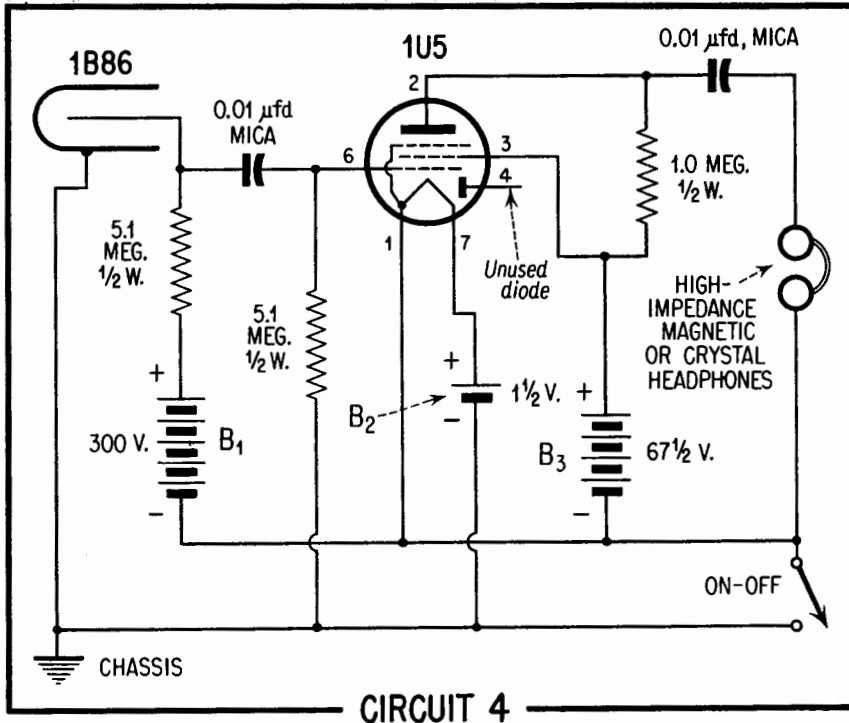

CIRCUIT 4

Because the 900-volt potential constitutes a serious shock hazard, we do not recommend connecting the headphones in series with the other elements in the way this was done in Circuit 1. Instead, high-impedance headphones are capacitance-coupled to the circuit through a 500-uufd 1500-volt mica capacitor. Crystal-type headphones can be used to advantage in this circuit.

The 1B85 is an aluminum wall tube having an A1-82 coaxial base. Its diameter is 51/64 inch, and its overall length, including the coaxial base, is 4 1/4 inches.

Because of the higher d-c voltage employed in Circuit 2, particular care must be exercised during construction of the instrument to insulate the various parts of the assembly.

To prevent leakage, use only high-grade non-hygroscopic insulating materials and keep all circuit points separated as widely as possible.

*Circuit 3.* In this arrangement, a pentode amplifier has been added to the rudimentary circuit (Circuit 1) to increase sensitivity and to provide louder clicks. Pulses from the 1B85 counter tube are transmitted to the grid of the 1U5 amplifier through coupling capacitor C<sub>1</sub>.

The midget 300-volt battery, B<sub>1</sub>, supplies both the counter tube and the plate and screen of the amplifier. The second battery, B<sub>2</sub>, is a 1 1/2-volt Size-D flashlight cell. The spst ON-OFF switch is connected to open both battery circuits simultaneously when in its OFF position.

Maximum efficiency will be obtained with high-impedance headphones. Crystal-type phones are recommended.

The shorter Type 1B88 counter tube also may be employed in this circuit.

*Circuit 4.* This is a variation of Circuit 3. Here, the plate and screen of the 1U5 tube have been disconnected from the important 300-volt battery and are supplied by the separate, midget 67 1/2-volt battery, B<sub>3</sub>. In all other respects, Circuit 4 is identical to Circuit 3.

This circuit change is important when the instrument is to be used regularly over protracted periods. Under such circumstances, removal of the tube drain from the 300-volt battery and the consequent longer life of this battery sufficiently offsets the additional cost, complication, and weight of the additional battery, B<sub>3</sub>, to warrant the modification.

The spst switch interrupts all three battery circuits when thrown to its OFF position.

*Circuit 5.* This is an interesting 300-volt Geiger counter which is powered from a single 1 1/2-volt Size-D flashlight cell. The high d-c voltage required for operation of the 1B86 counter tube is obtained by charging a capacitor through a high-turns-ratio stepup transformer.

The transformer may be any small universal replacement-type output unit, such as Merit A2900. Terminals A and B represent the entire primary winding of this transformer. (Do not use the center tap). Terminals C and D are two of the low-impedance connector lugs selected from the transformer connection chart for a turns ratio between CD and AB of 300 to 1, or higher.

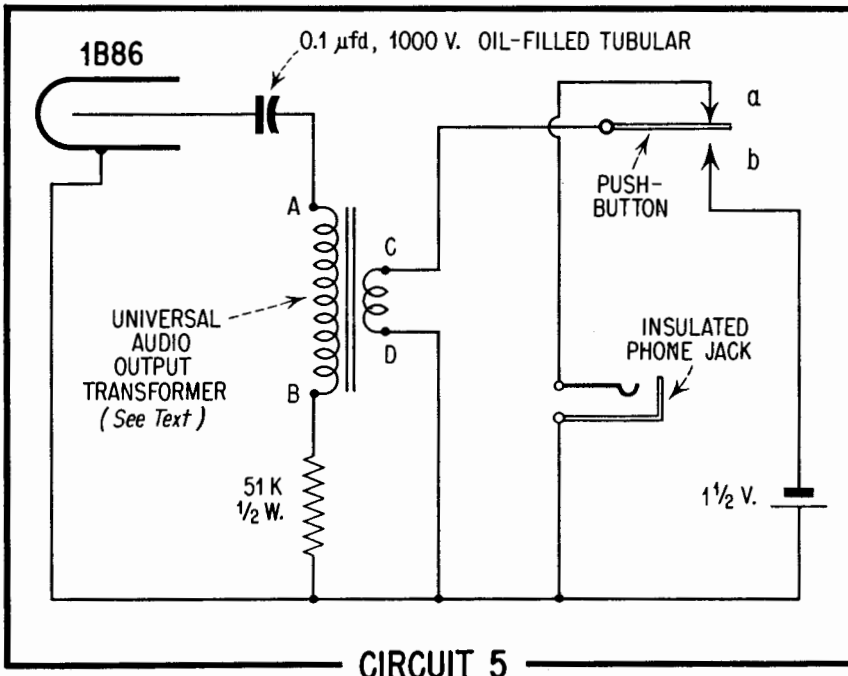

CIRCUIT 5

The spdt pushbutton switch normally rests in position a. This connects the headphones (plugged into the insulated phone jack) to the low-impedance winding of the transformer. When the switch is depressed and released momentarily, making a quick make-and-break connection in position b, a high-voltage pulse is induced across the high-turns winding, AB. This pulse fires the 1B86 tube and charges the 0.1-microfarad capacitor. Several repeated operations of the pushbutton switch will charge this capacitor fully. With the switch resting in position a, the capacitor cannot discharge through the circuit because of the insulating property of the 1B86 when it is not fired. The capacitor accordingly retains its charge and serves as a 900-volt source. When the counter tube is penetrated by a radioactive ionizing particle, however, it fires and induces a voltage across winding CD, and this produces a click in the headphones.

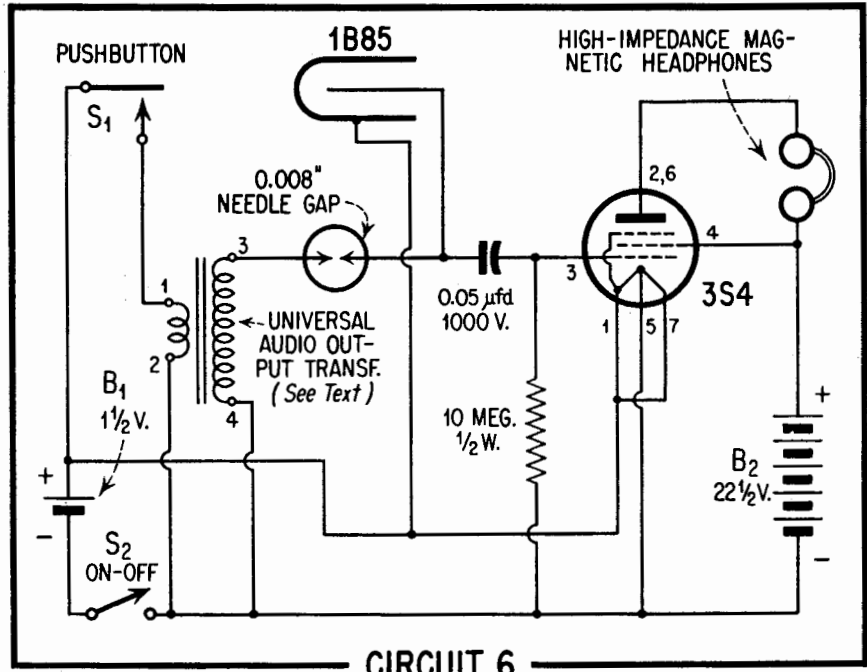

CIRCUIT 6

The length of time the capacitor will hold its charge depends upon the leakage characteristics of the capacitor and how well the circuit is protected from ambient humidity. This will vary from 5 to 30 minutes in most cases. As the charge leaks away, because of either leakage or rapid counting, the capacitor may be

re-charged readily by quickly pulsing the pushbutton switch several times.

Because of the nature of this circuit, very small size may be attained in the completed instrument. An added advantage is the fact that the headphones, being inductively coupled, are not included directly in the

high-voltage circuit and any possibility of shock, ground, or short circuit consequently is removed.

Circuit 6. The high potential of 900 volts is obtained in this circuit also by pushbutton-pulsing a 1 1/2-volt cell through a backward-connected universal output transformer to

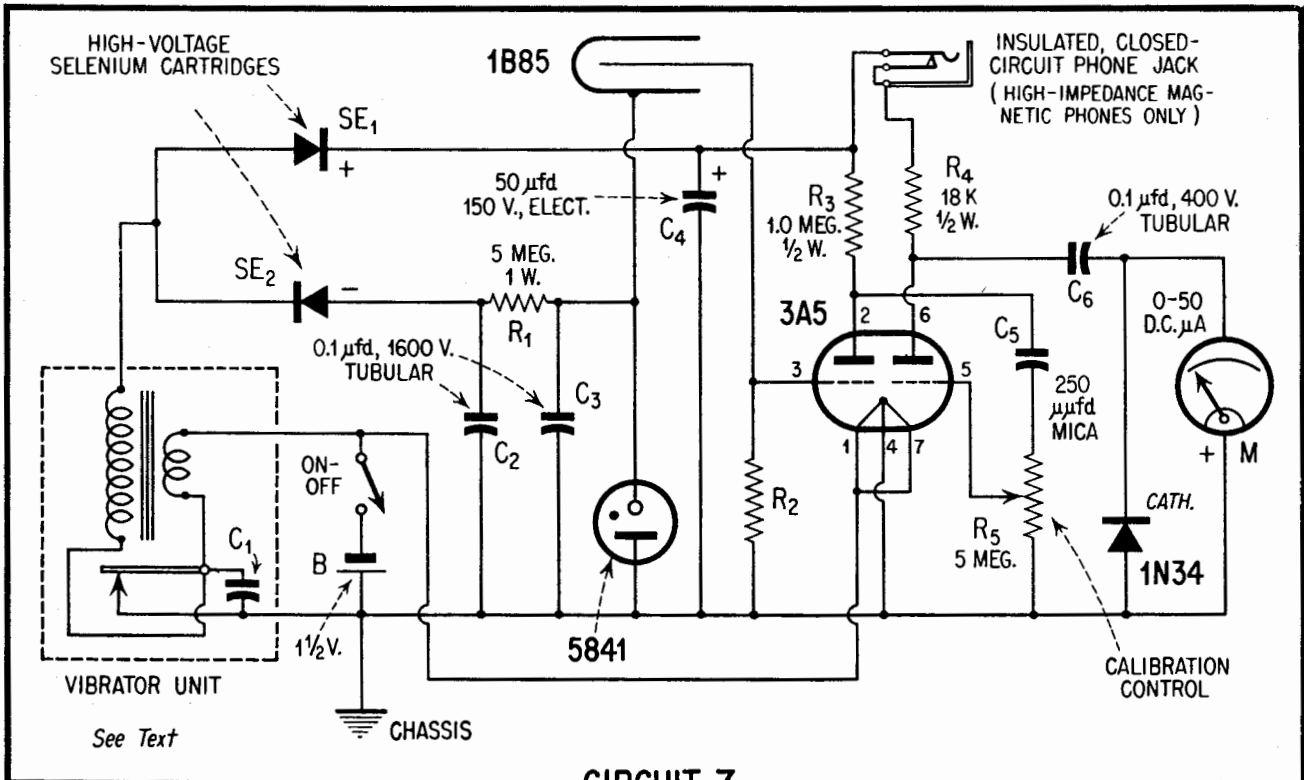

CIRCUIT 7

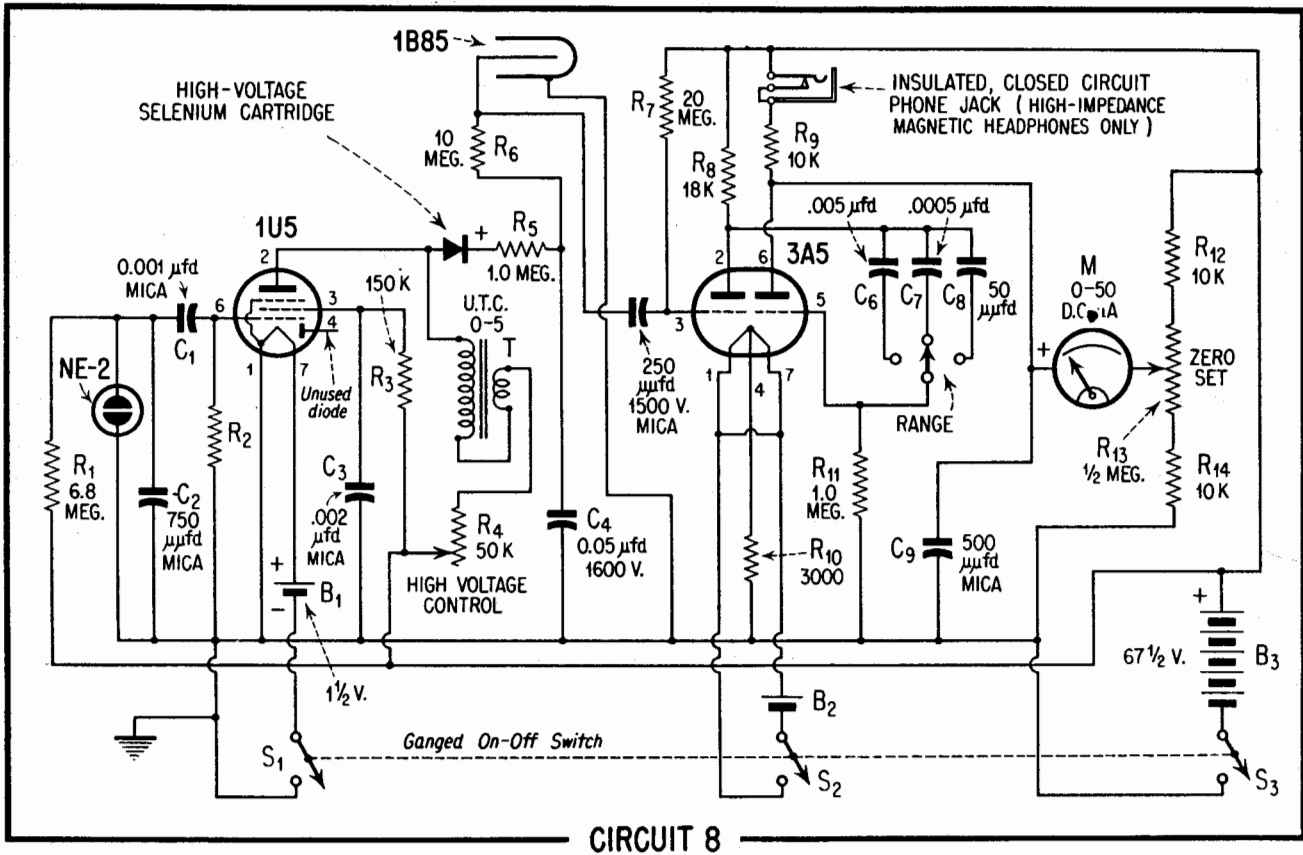

CIRCUIT 8

charge a capacitor. Here, however, terminals 1 and 2 of the transformer are the lugs (selected from the transformer connections chart) which supply the lowest impedance. This permits the highest stepup ratio. 3 and 4 represent the entire primary winding of the transformer. (Do not use the center tap.)

A small needle-type spark gap is connected between the 1B85 tube and the high-voltage winding of the transformer. A discharge takes place across this gap when the pushbutton (S<sub>1</sub>) is depressed and released, and the capacitor is charged. Several, successive, rapid pulsings of the pushbutton will charge the capacitor fully.

As the 1B85 tube fires under the influence of penetrating radioactive particles, the resulting pulses are presented to the grid of the 3A5 amplifier tube, and the amplified pulses are delivered to the headphones.

The 1½-volt battery, B<sub>1</sub>, supplies both the transformer and the 3A5 filament. The 22½-volt battery, B<sub>2</sub>, supplies only the plate and screen of the 3A5. For light-duty application, B<sub>1</sub> may be a single Size-D flashlight cell and B<sub>2</sub> a hearing aid battery. For more exacting work, B<sub>1</sub> should be made up of two or more Size-D cells connected in parallel, and B<sub>2</sub>

should be a midjet 22½-volt radio-type B-battery.

As in Circuit 5, the length of time that the capacitor will remain charged will depend upon ambient humidity and capacitor leakage and usually will be between 5 and 30 minutes. An occasional succession of rapid pulsings of the pushbutton switch, S<sub>1</sub>, will restore the charge.

**Circuit 7.** This Geiger counter has a self-contained, miniature, vibrator-type power supply operated from a single 1½-volt Size-D flashlight cell. The vibrator unit supplies the 1B85 counter tube and the 3A5 dual-triode amplifier tube. Meter readings, as well as headphone signals, are obtained with this circuit.

The miniature vibrator unit is a Model 10MVT, a product of Precise Measurements Co., Brooklyn, N. Y. It consists of a vibrator integral with a high-voltage transformer. The spark-suppressing capacitor, C<sub>1</sub>, is self-contained.

The high-voltage a-c output of the transformer is rectified by two sub-miniature high-voltage selenium cartridges. One of these, SE<sub>1</sub>, is poled to supply positive output for the 3A5 tube. The other, SE<sub>2</sub>, is poled for negative output for the 1B85.

The 50-microfarad, 150-volt electrolytic capacitor, C<sub>4</sub>, filters the 3A5 voltage, and its normal leakage holds this voltage approximately to 80 volts at 200 microamperes. The Victoreen Type 5841 regulator tube holds the counter tube voltage to a constant 900-volt level. Capacitors C<sub>2</sub> and C<sub>3</sub> and resistor R<sub>1</sub> form the high-voltage filter.

The 3A5 tube provides a 2-stage RC-coupled amplifier. The output triode is capacitance-coupled, through C<sub>6</sub>, to a rectifier-type voltmeter comprised by the 1N34 diode and the 0-50 d-c microammeter, M.

The meter deflection is proportional to the number of pulses per unit time arriving from the counter tube. Its scale may be calibrated at various settings of potentiometer R<sub>5</sub> (which might also be a step-type attenuator) with the aid of a series of calibrated radioactive samples held close to the 1B85 tube. Magnetic-type headphones inserted into the phone jack will provide aural indications. Since this jack is of the closed-circuit type, it will restore the plate circuit of the second triode automatically when the headphone plug is extracted.

**Circuit 8.** This circuit employs a 3A5 dual triode in a cathode-coupled one-shot multivibrator circuit. The multivibrator is triggered by pulses from the 1B85 counter tube. Each pulse switches the multivibrator on and off, causing a single pulse to be delivered to the metering circuit. Capacitors  $C_6$ ,  $C_7$ , and  $C_8$ , switched into the circuit, alter the pulse duration and repetition rate of the multivibrator and thus change the meter range. The microammeter thus is provided with several "total count" ranges. The microammeter scale accordingly may be calibrated in counts per unit time, milliroentgens per hour, or similar units. For this purpose, a series of calibrated radioactive samples may be employed.

Like a v-t voltmeter, the meter is set initially to zero in the absence of any input signal, by adjustment of

potentiometer  $R_{13}$ . An aural indication is obtainable from magnetic-type headphones plugged into the closed-circuit jack.

This multivibrator-type Geiger counter circuit is adapted from a similar one developed by Friedland. (See *Radiological Monitoring*. Stephen S. Friedland. QST, June 1951, p. 29).

The 900-volt potential for the counter tube is developed by a special power supply based upon a neon-bulb relaxation oscillator. Operated from the same 67½-volt battery,  $B_3$ , that furnishes the 3A4 plate voltage, the relaxation oscillator consists of resistor  $R_1$ , capacitor  $C_2$ , and the NE-2 neon bulb. The sawtooth voltage developed by this oscillator is applied to the grid of the 1U5 tube. A choke coil, consisting of a miniature "Ouncer" transformer, T, with its primary

and secondary connected together in series-aiding, is connected in series with the 1U5 plate. The rapid fall of current through this choke, due to the decay ("flyback") of the sawtooth wave, induces a high voltage across the choke. This high voltage then is rectified by the high-voltage selenium cartridge, filtered by  $R_3$  and  $C_4$ , and applied to the 1B85 tube. The high-voltage dc may be set exactly to the required level of 900 volts (preferably with the aid of an electrostatic voltmeter) by adjustment of potentiometer  $R_4$ .

A separate 1½-volt cell,  $B_2$ , is required for the 3A5 filament, since the cathode-coupled circuit in which this tube is used requires that the filament "float" 3000 ohms above ground.  $B_1$  and  $B_2$  are Size-D flashlight cells.  $B_3$  is a radio-type 67½-volt B-battery.

## Recent Trends in Single-Sideband Communication

FROM the days of the earliest radio-telephone transmissions, radio engineers and experimenters have been impressed with the fact that a conventional amplitude-modulated signal contains all its necessary intelligence in one of its sidebands. Yet associated with the transmission of this sideband is an identical additional sideband and a carrier component, so the total transmitted power amounts to six times that of a single sideband, which contains all the necessary intelligence. At the same time, the conventional amplitude-modulated signal takes up twice as much precious frequency spectrum bandwidth as a single sideband.

It has been found that certain types of fading, common with amplitude-modulated signals, are either eliminated or greatly reduced in single-sideband transmissions. This is particularly true of *selective* fading, which results from propagational phase variations between carrier and sidebands or between the two sidebands themselves. Elimination of the heavy and expensive high-level audio-frequency components of the conventional a-m transmitter is a powerful argument in favor of the single-sideband system.

Radio transmission with suppressed carrier and a single sideband has been used almost as long as the con-

ventional double-sideband amplitude-modulated type. It was employed for transatlantic radiotelephony at low frequencies as long ago as the early nineteen twenties. Because at that time the direct filter method was the only one generally applied, the inconvenience of heterodyning, instability of oscillator components and other factors limited practical use of such a system to the lower radio frequencies. In the last few years, development of high grade components and new techniques of circuitry have made single-sideband-suppressed-carrier (sssc) communication at higher frequencies more attractive. Improved stability and selectivity in

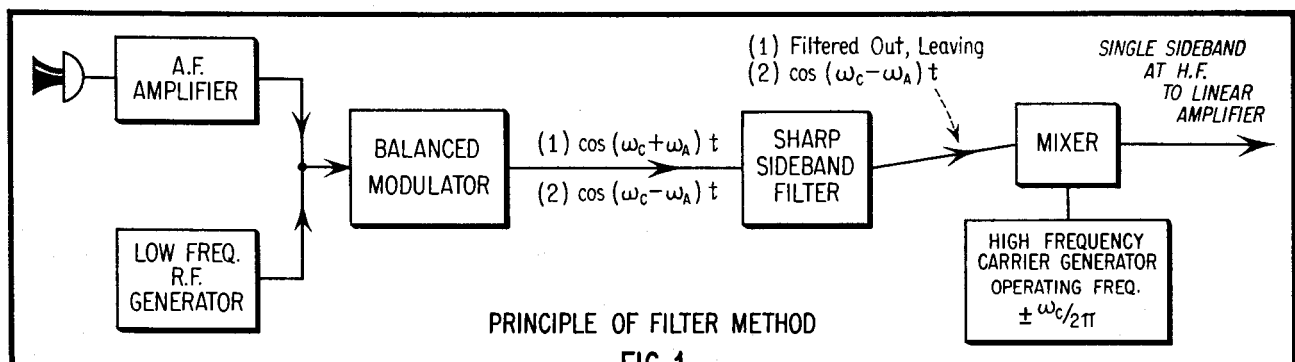



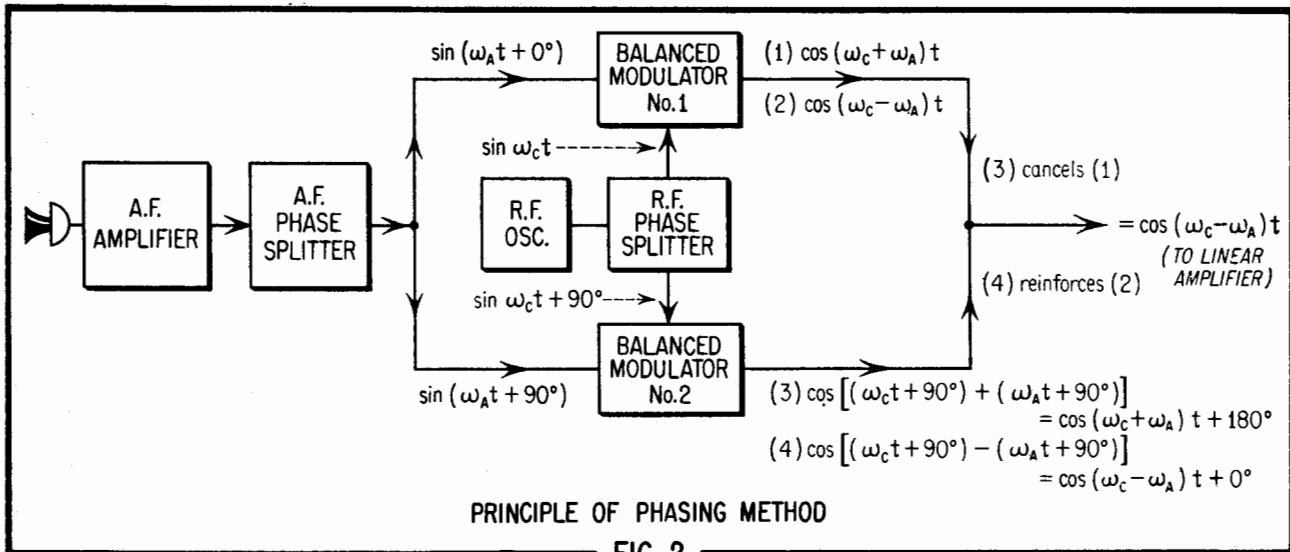

receivers and receiving systems have also been helpful in this development.

#### The Filter Method of Generating SSB Signals

Two main methods of generating single-sideband signals are generally employed: the filter method and the phasing method. The filter method is the older of the two, and in principle is simpler and more direct. This principle is illustrated in Fig. 1. The carrier is removed from the composite modulated signal by means of a balanced modulator. Then a filter with a sharp frequency characteristic, connected at the output circuit of the balanced modulator, removes the unwanted sideband.

In the filter method, the carrier must be generated at a relatively low radio frequency. If the radio frequency is too high, the percentage frequency spacing between the two sidebands is too small. Filters sharp enough to isolate the desired sideband would introduce too much phase distortion. Some amateur installations are using generated r-f carriers as high as nearly 500 kc for the filter method. Crystal lattice filters are used. However, in commercial practice it is common to keep the generated carrier between 20 kc and 100 kc. to ensure high filter efficiency and best attenuation of the unwanted sideband.

The single-sideband signal from the balanced modulator and filter is then transposed to the desired higher operating frequency by heterodyning with higher frequency carriers in one or more successive mixers. If the operating frequency is many times

that of the carrier of the sideband generator (as is ordinarily the case in high-frequency transmitters of the filter type), more than one stage of mixing is necessary. This is because when the mixer output frequency is very much higher than its input frequency, and the frequencies of the sum and difference heterodyne products are close, it is difficult to attenuate the unwanted heterodyne. The necessity for one or more mixing stages and lack of flexibility in switching from one sideband to the other are disadvantages of the filter method as applied to the higher communications frequencies.

#### The Phasing Method

In most cases, the need for mixer stages can be eliminated by use of the phasing method of single-sideband generation. In this method, the r-f carrier can be generated at the transmitter's output operating frequency. The principle is illustrated in Fig. 2. The mathematical expressions for the various signals, assuming a single-tone modulation signal, are given alongside their respective paths. Both the audio-frequency modulating signal and the carrier are divided, each into two components in quadrature. As shown, each phase component of the a-f signal is combined with one phase component of the carrier in a balanced modulator. In each case, the balanced modulator removes the carrier, leaving two sidebands in the output from each modulator. In the example given, assuming the use of a single modulation frequency, there would be just a single-frequency side-component on either side of the carrier frequency (but no carrier) in each case.

After the balanced modulators, their outputs are combined. The phase relations of the four sidebands (or single-frequency components) is such that one sideband is canceled while the other is reinforced. In the example illustrated, the carrier component which was shifted 90 degrees is modulated by the a-f component which was shifted 90 degrees. As can be seen by the mathematical expressions, combination in such phases results in cancelling of the high frequency sideband and reinforcement of the low frequency sideband. The phase of either the a-f or the carrier component can be reversed to provide high frequency sideband output instead of low frequency sideband output.

One of the critical sections of the phasing type transmitter is the audio phase shifter, which must provide two a-f signals 90 degrees apart at all frequencies in the modulation range. For the normal voice-communication frequency range, a simple RC network will accomplish this. A typical phase shift network for this purpose is illustrated in Fig. 3. One of the problems connected with such a circuit, of course, is the odd values required for most of the components. Special, non-standard components would have to be obtained.

However, a big step forward in making the phasing type of transmitter more practical was the provision by several manufacturers of complete phase shifting networks in very compact form. One of these standard commercially-available networks is completely enclosed in a metal tube envelope, of the same size as a 6J5

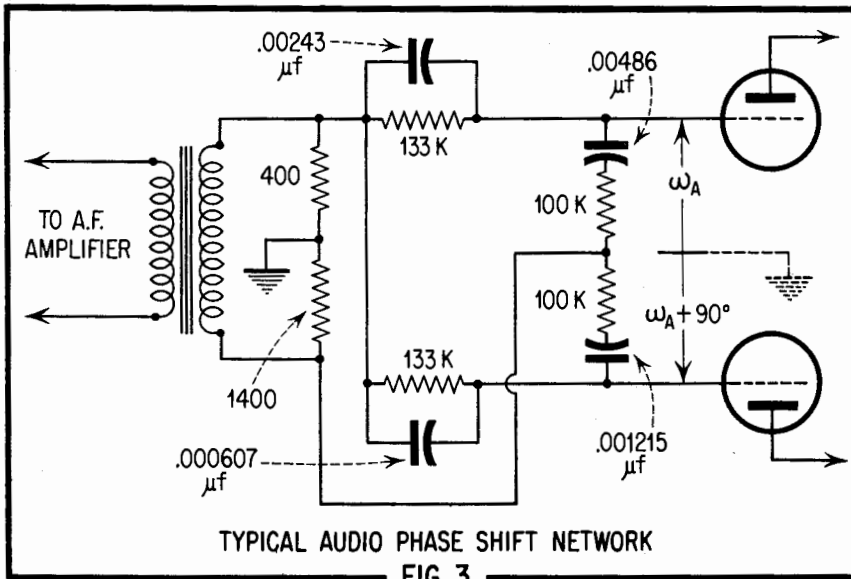

FIG. 3

tube, and plugs into an octal socket. It provides a 90-degree phase shift constant to within  $\pm 1.5$  degrees over an audio frequency range of 300 to 3,000 cps, adequate for voice communication purposes.

*Linear Amplifiers*

Use of sssc communication has spurred renewed attention to linear amplifier design. Two factors are important in these amplifiers: (1) low distortion, and (2) maximum power gain. Stability, which is very important, is interrelated with distortion, so is not classified separately.

Realization of the full advantages of the limited bandwidth of single-sideband transmission requires that distortion be well controlled. This

is especially true in services in which each sideband is used for transmission of different intelligence, in which case distortion manifests itself as splatter and noise effects between channels. Thus, low distortion can be considered even more important in ssb linear amplifiers than in the conventional carrier systems.

On the other hand, high power gain is also an important consideration. Single-sideband generators must be operated at relatively low levels. Thus, if linear amplifiers which follow do not have a high power gain, a large number of stages must be used and this is uneconomical and leads to unreasonable maintenance and adjustment requirements.

Under ordinary conditions, very low distortion and high power gain are not compatible. High power gain is seldom obtained with best linearity and lowest distortion. It is the reconciliation of these two factors which is the objective of most modern linear amplifier development.

The conventional grounded-cathode linear amplifier exemplifies the high-power-gain type, especially those circuits employing tetrodes and beam tubes. However, in the latter, optimum power gain is not consistent with minimum distortion. When the screen voltage is raised to a high enough level to minimize grid drive requirements, the static plate current becomes so high that the plate dissipation is likely to become excessive. On the other hand, when the static plate current is kept low, distortion is introduced. One way to maintain the low grid drive requirement and still keep static plate current limited is to use negative feedback.

One popular way to introduce feedback to improve linearity and stability is to use the grounded-grid circuit. Although this does provide excellent linearity, the power gain is low.

*Two-Stage Feedback*

A somewhat different arrangement for obtaining high power gain with low distortion has recently been suggested. In this arrangement, feedback around both stages is introduced. The first stage is operated class AB<sub>1</sub> and the second either AB<sub>1</sub> or AB<sub>2</sub>. A power gain of 5,000 with distortion reduction of up to 16 db over conventional circuits is claimed. Even though tetrodes are used, neutralization is provided; this is desirable to minimize single-stage instabilities. Less circuit "swamping" is then required.

*SSB Reception*

The most efficient method of reception of SSB signals is the phasing arrangement, which is the reverse of the transmission method illustrated in Fig. 2. A block diagram of the front end of the phasing type receiver is shown in Fig. 4. In applications in which a "pilot" carrier level is transmitted, automatic frequency control is employed in connection with the local oscillator. Otherwise, a suitable vernier adjustment of oscillator frequency must be available to facilitate manual control.

General improvement in component and material quality have contributed greatly in bringing ssb receivers to a relatively high state of development. The narrow pass band

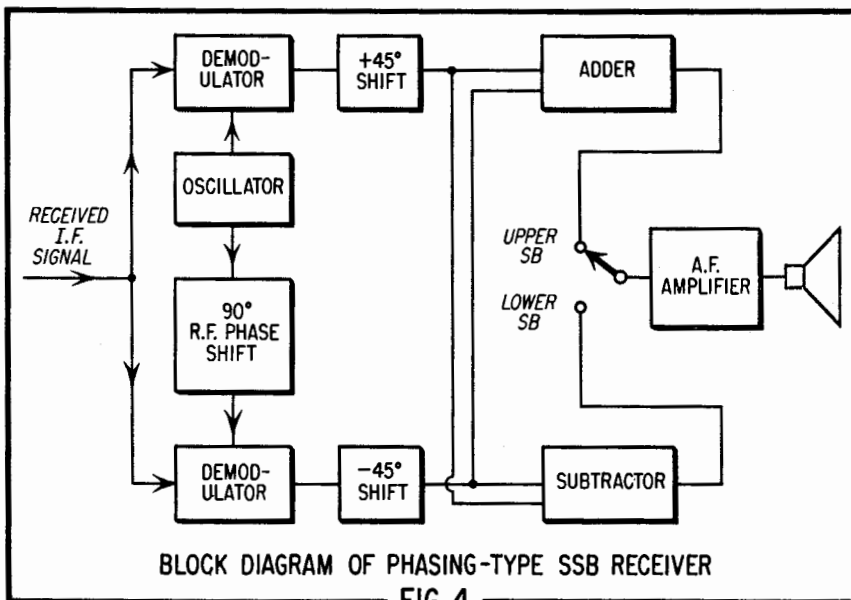

FIG. 4

(usually about 3 kc) and steep skirt selectivity desirable in this service can now be provided by crystal lattice filters or by the new mechanical i-f filters. These go a long way toward full realization of the full advantages

of the single-sideband system, which include improved signal-to-noise ratio, interference-rejection, and fuller use of valuable frequency spectrum. These are in addition to the propagational and economic advantages

previously mentioned.

In conclusion it may be said that present trends certainly indicate that before many years most communication services will have converted to single-sideband operation.

## The Citizens Radio Service

ON June 1, 1949 the Federal Communications Commission inaugurated the Citizens Radio Service on a regular licensing basis. Prior to that time, stations operating in this band (460-470 Mc.) were governed by experimental rules, pending finalization of the regulations by the FCC. The new service provides, for the first time, means whereby a private citizen may engage in two-way radio communication without being required to pass a technical examination.

Because of the simplicity of the new licensing procedure, and the long-standing need for such a service, it is anticipated that the citizens band will become a very important aspect of ultra-high-frequency radio. The following paragraphs contains a general discussion of the rules controlling this service, the technical requirements of the equipment employed, the possible applications of citizens stations, the propagation characteristics of this portion of the UHF band, and the implications of this new service in the servicing and manufacturing field.

### Regulations

The detailed regulations governing the Citizens Radio Service may be obtained from the Superintendent of Documents, U. S. Government Printing Office, Washington 25, D. C. for a fee of five cents. This reprint from the "Federal Register" of April 5, 1949 is designated "F. R. Doc. 49-2517." Application for Citizens Radio Service construction permit and station license may be made on FCC Form 505 to FCC Field Engineering Offices or to Washington, D. C.

In general, the rules provide for the operation of a citizens radio station by any citizen of the U. S. who is over eighteen years of age and who possesses citizens band equipment which has been approved by the FCC. The licensing procedure for those thus qualified is quite "streamlined," requiring merely the submission of the non-technical, single card

application form (Form 505). The normal term of the license is five years from the date of issuance. It authorizes the holder to communicate with other Citizens Radio Service licensees on a frequency-sharing basis for pleasure, utility, or indirect profit. By "indirect profit" it is meant that the service may be used as minor instrumentation in a business. For instance, a doctor might use the citizens band for a private call system to maintain contact with his home or office. The service may not charge for messages, handle program material in any way connected with radio broadcasting, transmit directly to the public through public address systems, or for other purposes contrary to Federal, state or local law. The FCC regulations define the Citizens Radio Service as "a fixed and mobile service intended for use for private or personal radio communication, radio signalling, control of objects or devices by radio, and other purposes not specifically prohibited herein." The artists sketch of Fig. 1 illustrates the most popular concept of such "personal radio communication."

Due to the non-technical nature of the citizens license requirements, this frequency allocation is not intended as an experimental band. All station equipment must be type ap-

proved by the FCC before the issuance of a station license. Any transmitter adjustments or maintenance which might effect its operating characteristics must be made by, or under the direct supervision of, the holder of a first- or second-class commercial license. The Commission must be notified of any major modifications which are made to the equipment during its use.

The regulations do, however, provide for the licensing of "composite" equipment which complies fully with the technical requirements of the Citizens Radio Service. The procedure for obtaining FCC approval for the construction and operation of such equipment is considerably more complicated than that outlined above for the case of commercially manufactured, type-approved equipment. Supplementary information, describing the complete design and testing of the composite equipment, must be submitted to demonstrate that it will comply with the rigorous engineering specifications. In some cases the FCC may require that the completed equipment be submitted to its laboratory for type-approval testing. The majority of war surplus radio equipment available in this frequency range, such as the BC-645 air-borne transponder beacon, has been found by the FCC to fall far short of the required technical standards of the service.

### Technical Requirements

Two classes of licenses are issued which authorize operation of a station within the 460-470 Mc. citizens band. Fig. 2 shows the allocation of frequencies in the band according to class of license. The Class A license requires that the transmitter frequency be maintained constant to within plus or minus .02% of the intended operating frequency, and authorizes operation throughout the entire band. The Class B license permits frequency deviations up to plus or minus .4%



FIG. 1

of the mid-band frequency (465 Mc.) and all operation must be confined to this band. The maximum power input to the final tube or tubes in the transmitter for the three subdivisions of the band is also shown in Fig. 2.

The technical requirements of the Class A license effectively exclude all but carefully engineered, crystal controlled transmitters. No other known method of transmitter frequency control will dependably meet the .02% tolerance specified. Since low-drift quartz crystal oscillators are available only at relatively low frequencies, it is necessary to use a multi-stage transmitter to multiply the crystal frequency to the required citizens band frequency. The usual extent of such a crystal controlled transmitter is illustrated in block form in Fig. 3. It is common practice to accomplish the frequency multiplication in low power stages and use the output of these to drive a high-gain power amplifier at the output frequency.

It is evident from Fig. 3 that the Class A requirements may be most easily met by stations operating at fixed locations, or in the more elaborate mobile installations. The inherent complexity of the high stability equipment and the accompanying heavy power drain make the hand-portable "walkie-talkie" type of operation improbable. High quality equipment is necessary for operation near the edges of the citizens band to avoid interference with important commercial services on adjacent frequencies. The recent allocation of UHF television channels starting at 475 Mc. makes the good conduct of stations in the Citizens Radio Service even more imperative. For this reason equipment meeting FCC approval must be as "fool-proof" as possible. Since it is intended for use by non-technical personnel, no control effecting the frequency of transmission should be accessible from the exterior of the equipment housing.

It is the Class B license which is intended to authorize the operation of greatly simplified portable communication equipment which might be carried on the person in the manner of the war-time "walkie-talkie" or "handie-talkie" sets. This mode of operation has the greatest appeal to the public and probably the greatest potential field of application. The technical requirements of this license may be met by relatively simple, lightweight sets of the "transceiver" type, in which the functions of transmitting and receiving are performed by the

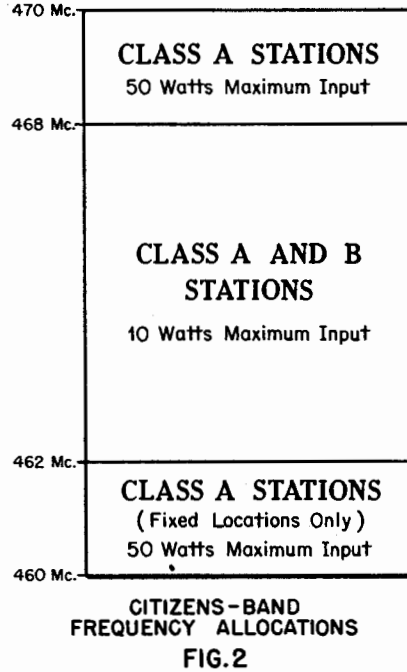

same tubes. Fig. 4 shows the minimum equipment requirement for such a station in block form. The transmitter is a self-excited oscillator, modulated by one or two audio amplifier stages driven by a high-output microphone. During receiving, the bias and plate voltage on the oscillator tube are switched to convert it to a superregenerative detector. The antenna remains coupled in the same manner, and the audio section is used to amplify the detected signal and drive a small speaker or headphones. The complete transition from "transmit" to "receive" is accomplished by a single switch or relay.

Although equipment of the transceiver type has been approved by the

FCC for use in the citizens band, very careful engineering is required to comply with the Class B regulations. This difficulty is due to several inherent limitations in the performance of modulated, self-excited oscillators and transceivers in general. These limitations may be listed as follows:

(a) *Transmitter frequency instability.* The inherent frequency stability of most self-excited oscillators in the UHF range is very poor. The frequency is effected by changes in applied voltage, capacity changes caused by thermal expansion of vacuum tube elements, changes in ambient temperature and humidity, capacity variations due to proximity effects, antenna loading variations, and mechanical vibration. Voltage fluctuations due to plate modulation alone may cause frequency modulation amounting to several hundred kilocycles. The combined result of such effects is to make it exceedingly difficult to design an oscillator at 465 Mc. which will meet the prescribed tolerances in the hands of the public.

(b) *Receiver radiation.* The great simplicity of the transceiver results from the dual use of the tubes. However, when the transmitting tube is used as a superregenerative detector coupled directly to the antenna, a signal which is pulsed at the frequency of quenching is radiated. This signal is a potential source of interference to other citizens radio stations and adjacent services. Receiver radiation may be prevented by the addition of an r. f. stage between the antenna and the "superregen" detector, but the presence of this stage complicates the function of transmit-receive switching considerably.

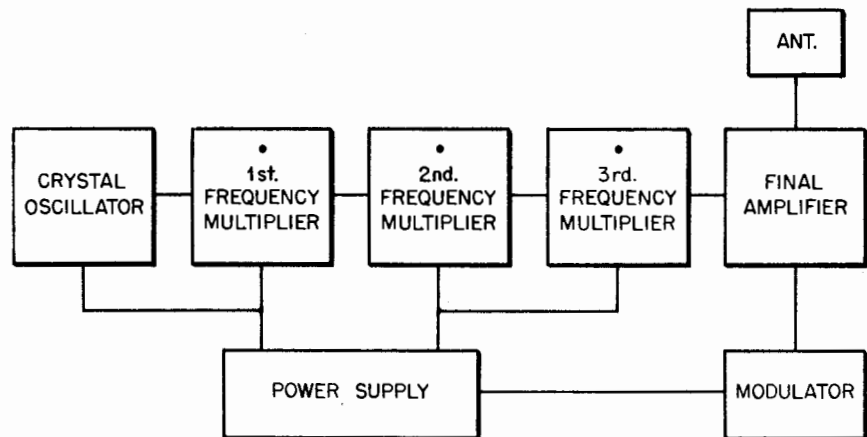

**CRYSTAL-CONTROLLED UHF TRANSMITTER**  
FIG. 3

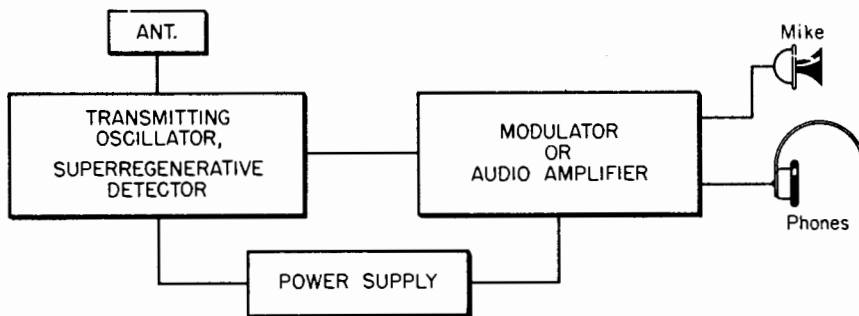

TRANSCEIVER BLOCK DIAGRAM  
FIG. 4

(c) *Transmit-receive frequency difference.* Due to the change in operating voltage, there is a considerable difference between the frequency of transmission and reception in most transceivers. This discrepancy in frequency has the effect of causing two stations in communication to drift around the band unless the transmitter of each is retuned to a given frequency before every transmission.

Nevertheless, the transceiver presents a very inviting approach to the problem of simple and economical equipment for the Citizens Radio Service, and the solution of its limitations is a challenge to equipment designers.

#### Propagation Characteristics

Because the citizens band allocation is in the UHF portion of the radio spectrum, communication is usually limited to virtual line-of-sight distances. Stations using a few watts input, as is characteristic of stations of the "man-portable" kind,

are able to communicate for distances ranging from a few blocks in very populous city areas, to several miles in residential districts having fairly flat terrain. Over truly optical paths, such as might exist between stations operating at elevated locations, appreciable distances may be spanned, even with very low power. The present record for amateur communication in the 420-450 Mc. band is 262 miles.

Waves at these frequencies are attenuated considerably by dense foliage. Antennas should, therefore, be above tree-top level wherever possible. Because of the portable applications of the service, vertical antenna polarization will be favored for its omnidirectional properties.

There are also very pronounced "shadowing" effects behind hills, tall buildings, and other large obstructions at these frequencies. In many cases, however, reception at such sites may be made possible by indirect path

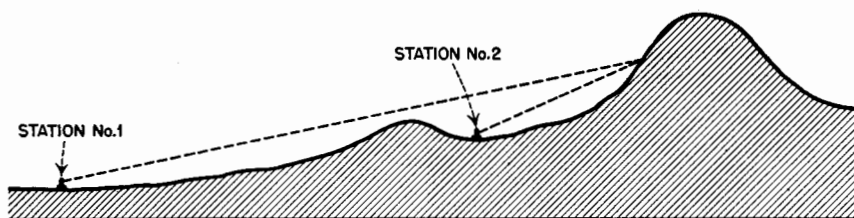

SHOWING UHF COMMUNICATION BY REFLECTED WAVES  
FIG. 5

propagation of the type illustrated in Fig. 5. By this means, radio waves reflected by other large obstacles may reach the receiver by indirect routes.

Citizens stations using the high-performance equipment specified for the Class A license, and the greater power permitted under these conditions, should enjoy considerably greater dependability of communication. The use of very stable transmitters will permit relatively narrow-band, high-gain superhetrodyne receivers to be employed. The resulting improvement in receiver sensitivity should enable this type of station to communicate over distances several times greater than those covered by Class B stations. High-gain directional antennas may be employed by stations at fixed locations.

#### Commercial Aspects

The Citizens Radio Service represents a new field of endeavor for the manufacturer and radio service man. Since the licensing procedure for the service is based primarily upon the availability of commercially manufactured equipment, a large potential market exists for type-approved sets which can be economically produced. The high cost of satisfactory equipment for two-way radiotelephone communication is at present a major drawback in the expansion of this service.

In a similar manner, citizens radio provides a lucrative field for the service man who equips himself with a commercial radiotelephone license so that he may legally engage in installation and maintenance of citizens radio sets. As the service grows and gains in popularity it should be possible for an enterprising technician to build up a large clientele of citizens band licensees. Since the service man will have to assume responsibility for the proper functioning of the equipment under his care, it will be necessary for him to acquire some specialized test equipment, such as a precision UHF wavemeter, for this purpose.

## ELEMENTARY BINARY ARITHMETIC

WITH the growing presence of digital electronic computers among us, more and more radio technicians are beginning to hear obliquely about the *binary* number system

and wonder why they have learned nothing about it before. There is good excuse for the perplexity, since surprisingly little has appeared on the subject in the books and magazines

customarily read by radio men. Many technicians who have prided themselves on being reasonably well grounded have thumbed through mathematics textbooks, old and new,

and found no reference whatever to the binary system!

A glance into the dictionary reveals the word binary to mean "characterized by two things or parts." From this, we may infer, correctly, that binary arithmetic is in some way associated with the figure 2. Indeed, the binary system uses only two digits. Now, let us see how this differs from the method of counting we have employed most of our lives.

Our old standby is the decimal system. Its base is 10 and its digits are 0, 1, 2, 3, 4, 5, 6, 7, 8, and 9. This is very handy because we have ten fingers on which to count. In our civilization, we have gotten along famously with the base 10. It is possible to express any number by the proper combination of the digits 0 to 9. However, when we attempt to set up some forms of electrical counting equipment in strict accordance with the decimal system, we find ourselves in need of a multitude of components.

Here, the binary method comes to our rescue. It is a base 2 system and requires only two digits: 0 and 1. In the binary system, all numbers can be expressed by combinations of zeros and ones. Just why should this be handier than the decimal system? Simply because it is an easy matter to express the binary digits themselves with a simple electrical device which is either ON (1) or OFF (0). Thus, an open switch or relay denotes zero, while a closed switch signifies 1. The same is true of a tube conducting or cut off, a crystal diode conducting or blocking, a neon lamp ignited or extinguished, etc., etc. A voltage or current likewise can denote 1 when high or positive, and zero when low, negative, or off. The binary system operates with fewer and simpler components.

Although a certain piece of equipment, such as a counter, might operate by the binary method, it still can be made to give indications (such as total count) in the easily-recognized decimal notation.

In explaining the elements of binary arithmetic in this article, frequent

comparisons will be made with the decimal system for the sake of clarity or proof.

#### Rudiments of the System

Suppose that you have four separate on-off components (switches, tubes, etc.), each of which is assumed to indicate zero when OFF and 1 when ON. Table I shows how the two states of these same four devices can be employed to express various decimal numbers.

In order better to understand this table, let us consider the basic rules of binary addition which may be stated as follows:  $0 + 0 = 0$ ,  $0 + 1 = 1$ ,  $1 + 0 = 1$ , and  $1 + 1 = 10$ . This last sum means simply that every time 1 is added to 1, we write down zero and carry the 1 to the next column to the left. An illustration will serve to clarify binary addition. For example, from Table I add 0101 (binary 5) and 0011 (binary 3):

BINARY	DECIMAL
0101	5
+ 0011	+ 3
-----	-----
1000	8

First, the two 1's in the right-hand column are added. This equals 10, so we write 0 and carry 1 to the next column to the left. This 1 must be added to the 1 already in that column. Again, this equals 10, so we write 0 and carry 1 to the next column to the left. Adding this carried 1 to the 1 already in that column gives another 10, so we write another zero and carry 1 to the left-most column. Now, this 1 is added to the zero in that column, giving 1 which is written. The answer is 1000, which by reference to Table I is found to be binary 8.

A careful examination of Table I now reveals that each higher binary number is obtained by adding binary 1 (0001) to the preceding number. Try this out by starting with 1010 (binary 10) and successively adding

0001 (binary 1). You will obtain 1011 for 11, 1100 for 12, 1101 for 13, 1110 for 14, and 1111 for 15. If you make another addition, you will obtain 10000 (binary 16) which requires five on-off devices for its expression — and we agreed at the beginning that we have only four. So binary 15 is as high as a 4-device system will count. However, the economy and efficiency of the system is realized when it is considered that only four elements are needed to display from 0 to 15 events.

Any number may be expressed in the binary system by choice and position of the two digits repeated as coefficients of powers of 2, just as any number can be expressed in the decimal system by choice and position of the ten digits of that system as coefficients of powers of 10. For example: The decimal number 2548 means  $2 \times 10^3 + 5 \times 10^2 + 4 \times 10^1 + 8 \times 10^0$ . Similarly, the binary number 011010 means  $0 \times 2^5 + 1 \times 2^4 + 1 \times 2^3 + 0 \times 2^2 + 1 \times 2^1 + 0 \times 2^0$ . Table II lists the powers of 2 up to  $2^{25}$ , and you can obtain from this Table the decimal numbers corresponding to the powers of 2 given in the preceding example. Adding these discloses that 011010 equals 26:

$0 \times 2^5 =$	0
$+ 1 \times 2^4 =$	16
$+ 1 \times 2^3 =$	8
$+ 0 \times 2^2 =$	0
$+ 1 \times 2^1 =$	2
$+ 0 \times 2^0 =$	0
-----	-----
011010 =	26

You can prove this sum by returning to Table I and adding binary 1 (0001) successively to binary 10 until you reach 011010 which you will find equal to 26.

A binary point is used in binary notation just as a decimal point is used in decimal notation. An example is 100101.01 with six digits on

the left and two on the right of the binary point, although the digits might increase in number without limit on both sides of the point. We have seen already that the digits on the left of the point are coefficients of increasing positive powers of 2 with  $2^0$  adjacent to the binary point. The digits on the right are coefficients of increasing *negative* powers of 2 with  $2^{-1}$  adjacent to the point. The example just given (100101.01) becomes:

$1 \times 2^5 = 32$
$+ 0 \times 2^4 = 0$
$+ 0 \times 2^3 = 0$
$+ 1 \times 2^2 = 4$
$+ 0 \times 2^1 = 0$
$+ 1 \times 2^0 = 1$
$+ 0 \times 2^{-1} = 0$
$+ 1 \times 2^{-2} = 0.25$
<hr/>
<b>100101.01 = 37.25</b>

*Binary Addition*

The addition of positive numbers in the binary system already has been explained in the preceding paragraphs. While the addition of *two* numbers has been given in each illustration, the system is by no means restricted to 2-number groups. Any series of binary numbers can be summed.

The only remaining case is the addition of a positive and a negative number. Consider, for example, the addition of 0101 and -0010.

DECIMAL	BINARY
5	0101
-2	-0010
<hr/>	<hr/>

The technique is to change the sign of the negative number, then complement this number, and *add* the result to the positive number. To complement the number, change each of its

1's to 0's and each of its 0's to 1's and add 1. Thus, -0010 becomes:  $1101 + 1 = 1110$ . Now if we add:

0101
+ 1110
<hr/>
10011

Here, the left-most digit in the answer is discarded. If it is 1, the sign of the answer is positive, as in the above case. The answer thus is + 0011, or binary 3 which satisfies the condition of  $5-2 = 3$ .

If the left-most digit is zero, the sign of the answer is negative and the result must be recomplemented (the same process as the original complementing) to give the correct answer. This always happens when a negative number is added to a smaller positive number. Thus: Add -1000 (binary 8) to 0011 (binary 3):

$0011 + (-1000) = 0011$
+ 1000 = 01011
-1000
<hr/>
<b>complemented</b>

Dropping the left-most 0 in the answer (which merely indicates the negative sign), and recomplementing changes 1011 to -0101 (binary 5), which is the correct answer.  $-8 + 3 = -5$ .

*Binary Subtraction*

Subtraction is the same as the addition of positive and negative binary numbers, as just described. For example: Subtract 0100 (binary 4) from 1010 (binary 10).  $1010 - 0100$  becomes  $1010 + 1100$  when the negative number (subtrahend) is complemented and its sign changed. This equals 10110. The left-most digit, being a '1, indicates that the sign of the answer is positive and is discarded, making the answer +0110 (binary 6) which is correct.

*Binary Multiplication*

Binary multiplication is carried out in very much the same manner as decimal multiplication, obtaining partial products in the conventional manner, but adding the latter in binary fashion. In binary multiplication,  $0 \times 0 = 0$ ,  $0 \times 1 = 0$ ,  $1 \times 0 = 0$ , and  $1 \times 1 = 1$ .

As an example, multiply 0101 (binary 5) by 0010 (binary 2):

0101 = 5
$\times 0010 = \times 2$
<hr/>
0000      10
0101
0000
0000
<hr/>
0001010 = 1010 = 10

*Binary Division*

Binary division is carried out in a manner similar to decimal division, as the following example will show: Divide 1001 (binary 9) by 0100 (binary 4):

$10.01 = \text{ans.}$
<hr/>
0100 ) 1001
100
<hr/>
000100
<hr/>
<b>The quotient 10.01 =</b>
$0 \times 2^3 = 0$
$+ 0 \times 2^2 = 0$
$+ 1 \times 2^1 = 2$
$+ 0 \times 2^0 = 0$
$+ 0 \times 2^{-1} = 0$
$+ 1 \times 2^{-2} = 0.25$
<hr/>
<b>10.01 = 2.25</b>

*Conclusion*

**TABLE I.**

<b>DECIMAL NUMBER</b>	<b>BINARY NUMBER</b>
0	0000
1	0001
2	0010
3	0011
4	0100
5	0101
6	0110
7	0111
8	1000
9	1001
10	1010

After studying the rudiments of binary arithmetic presented here, the reader should be able, by setting up for himself a number of practice examples for drill, to acquire considerable proficiency in manipulating this invaluable new tool. A good working knowledge of the binary system is essential to comprehending the operation of digital electronic computers and of other instruments, such as counters, which utilize the digital techniques.

**TABLE II.**

$2^0$ . . . . 1	$2^{13}$ . . . . 8192
$2^1$ . . . . 2	$2^{14}$ . . . . 16,384
$2^2$ . . . . 4	$2^{15}$ . . . . 32,768
$2^3$ . . . . 8	$2^{16}$ . . . . 65,536
$2^4$ . . . . 16	$2^{17}$ . . . . 131,072
$2^5$ . . . . 32	$2^{18}$ . . . . 262,144
$2^6$ . . . . 64	$2^{19}$ . . . . 524,288
$2^7$ . . . . 128	$2^{20}$ . . . . 1,048,576
$2^8$ . . . . 256	$2^{21}$ . . . . 2,097,152
$2^9$ . . . . 512	$2^{22}$ . . . . 4,194,304
$2^{10}$ . . . . 1024	$2^{23}$ . . . . 8,388,608
$2^{11}$ . . . . 2048	$2^{24}$ . . . . 16,777,216
$2^{12}$ . . . . 4096	$2^{25}$ . . . . 33,554,432

Positive Powers of 2.





## INDEX

### A

AM detector test, 80  
Air dielectric capacitors, 39, 40

### B

Bandwidth, 4  
Bifilar winding, 21  
Blocking oscillator, 58  
Booster station, 12  
By-pass condensers, proper use of, 41-44  
    cathode, 42, 43  
    plate, 43  
    precautions, 43, 44  
    screen, 43

### C

Capacitive feedback, 17  
Capacitors, fixed, 39-41  
    air dielectric, 39  
    ceramic, 40, 41  
    electrolytic, 41  
    mica, 40  
    paper, 41  
Cathode by-pass, 42, 43  
Ceramic capacitors, 40, 41  
Citizens radio service, 112-114  
    commercial aspects, 114  
    propagation characteristics, 114  
    regulations, 112  
    technical requirements, 112, 113  
Class-B transistor amplifier circuits, 101  
    design and operation, 101, 102  
Coefficient of coupling, 5  
Colpitts oscillator, 19  
Community antenna system, 14  
Crystal diodes, 49-51  
    applications, 50, 51  
    construction, 49  
    crystal types, 49, 50  
    electrical advantages, 49  
    silicon crystals, 51  
Current meter, 67, 68

### D

D'Arsonval movement, 67  
DC meter, 67-69  
Differentiator circuits, 56  
    mutual inductance, 57  
Diode clipper, 60

Diode type resistor, 48  
Discharge tube, 59  
Distortion analyzer, 63-65  
    construction, 64, 65  
    using, 65  
Distortion measurements, audio, 60-65  
    distortion analyzer, 63-65  
    harmonic wave analyzer, 61, 62  
    intermodulation analyzer, 62, 63  
    meter, 61  
    methods of measurement, 60-63  
Distortion meter, 61  
Distortion, types of, 60, 61  
Dual I.F. systems, 2  
    response curve, 3

### E

Electrolytic capacitors, 41  
Electrometer, application of, 72-77  
    capacitance and resistance measurements, 77  
    current measurements, 74-76  
    voltage measurements, 75, 76  
Elementary binary arithmetic, 114-117  
    addition, 116  
    division, 116  
    multiplication, 116  
    subtraction, 116

### F

Ferroresonant circuits, 34-38  
    flip-flops, 35-37  
    response curve, 35  
Filamentary devices, 47, 48  
Flyback supply, 7

### G

Generators and non-linear shapers, 57-60  
Geiger counters, 104-109  
    typical circuits, 105-109  
Germanium diodes, 50, 51

### H

Harmonics, 10, 23, 24, 61, 62  
    checking of, 24  
Harmonic checker, 10  
Harmonic wave analyzer, 61, 62  
Hartley oscillator, 18-20  
    grounded plate, 20

High-voltage supplies, 6-9  
filter circuit, 7  
flyback, 7  
pulse type, 8  
RF supply, 8

## I

Inductive feedback, 16, 22  
pentagrid circuit, 21  
Industrial safety controls, 89, 90  
Integrator circuits, 56  
Intercarrier sound, 1-3  
circuit, 3  
response curve, 3  
Intermodulation analyzer, 62, 63

## J

Junction transistor, 95-99  
cascaded amplifiers, 97, 98  
characteristics, 95  
circuits, 96, 97  
oscillator circuits, 98, 99

## L

Lead dress, 53, 54  
Line filter, 10  
Local oscillators, AM receivers, 20-24  
requirements, 20-24

## M

Meter accuracy, 69  
Mica capacitors, 40, 41  
Mounting circuit components, 51, 52  
Multivibrator, 58

## N

Negative resistance, 15  
Noise generator, crystal type, 82-84  
circuit of, 82  
construction, 84  
operation, 84  
Non-electronic DC voltmeters, 69-72  
construction, 71  
sensitivity and resistance, 71  
use of, 71, 72  
Non-linear resistors, 44-48  
diode type, 48  
filamentary devices, 47, 48  
thermistors, 47  
thyrite, 44-46  
Non-sinusoidal wave forms, 55-60

## O

Ohmmeter, 68, 69  
Oscillators, 15-31, 98, 99  
AM receivers, 20-24  
bifilar winding, 21  
Colpitts, 19  
definition of, 15

Oscillators—*continued*  
dual triode, 22  
frequency stability, 22  
Hartley, 18  
pentagrid, 21  
tracking, 24-27  
transistor, 98, 99  
tuned grid, 16  
tuned plate, 16  
tuned plate tuned grid, 17  
VHF and UHF, 27-31  
Overdriven amplifier, 59

## P

Paper capacitors, 41  
Passive TV relaying, 13  
Passive wave-shaping circuits, 55-57  
Photoconductive cells, 90  
Photoelectric cell applications, 87-90  
counting system, 89  
gages, 90  
industrial safety controls, 89, 90  
Photoelectric counting system, 89  
Photoelectric gages, 90  
Phototubes, 88, 89  
Photovoltaic cells, 90  
Plate by-pass, 43  
Printed circuits, 90-92  
connecting wires, 91  
printing techniques, 91  
on tube envelope, 91  
servicing, 92  
Propagation disturbance notices, 85, 86  
Pulse type high-voltage supply, 8

## R

Reception at shadowed locations, 12-14  
Regulated power supply, 32-34  
construction, 34  
design considerations, 33  
theory of operation, 32  
Relaxation oscillator, 37, 58  
R.F. high voltage supply, 8

## S

Satellite stations, 13  
Screen by-pass, 43  
Semiconductor diodes, testing of, 77-82  
AC tests, 79, 80  
AM detector test, 80  
checking recovery time, 81, 82  
DC tests, 78, 79  
rectification efficiency, 79  
television diode test, 80  
visual test method, 81  
Sequential flasher, 38  
Servicing printed circuits, 92  
Silicon crystals, 51  
Single-sideband communication, 109-112  
generating SSB signals, 110  
linear amplifiers, 111

Single-sideband communication—*continued*

- phasing method, 110
- principle of, 109, 110
- SSB reception, 111, 112
- two-stage reception, 111, 112

Slug-tuned coils, 26, 27

Stagger tuning, 5, 6

**T**

Television diode test, 80

Television interference filters, 9-11

Thermistors, 47

Thyrite resistors, 44-46

- circuits, 45, 46

Tracking, oscillator, 24-27

- circuit, 25
- error curve, 25

Transistors, 92-104

- amplifying crystal, 92-95
- base-collector curves, 100
- basic circuit, 93
- characteristics, 94, 95
- class-B amplifier, 99-102
- emitter-collector curves, 100
- junction, 95-99
- load lines, 102-104
- maximum power output, 104

Transmission line tank circuit, 31

Transmitter filter, low pass, 11

Tuned circuit feedback, 18, 19

Tuned grid feedback, 16

Tuned plate feedback, 16

Tuned plate tuned grid circuit, 17

TVI, 9-11

- causes of, 9
- reduction at receiver, 11
- reduction at transmitter, 9, 10

TV receiver filter, high pass, 11

**U**

Ultradion circuit, 29-30

- hairpin tank, 30, 31
- used in TV, 30, 31

Using standard time and frequency broadcasts, 85-87

- accuracy of transmissions, 86
- audio frequency comparisons, 87
- calibration, low frequency R.F., 86, 87
- carrier frequency checks, 86
- methods of comparison, 86

**V**

VHF and UHF oscillators, 27-31

- circuit construction, 29, 30
- problems, 27, 28
- size, 28, 29
- transmission line tank, 31
- types of circuits used, 30, 31

Video I.F. amplifiers, design of, 4-6

- bandwidth, 4
- response curve, 5

Voltmeter, D.C., 68

**W**

Wiring and cabling, 52

Wiring techniques, 51-54

WWV and WWVH, 85, 86

**Electronics**

**Reference**

**Data**

